

AperTO - Archivio Istituzionale Open Access dell'Università di Torino

## Alternative molecular tests for virological diagnosis

### **This is the author's manuscript**

*Original Citation:*

*Availability:*

This version is available <http://hdl.handle.net/2318/146396> since

*Published version:*

DOI:10.1007/s12033-012-9533-8

*Terms of use:*

Open Access

Anyone can freely access the full text of works made available as "Open Access". Works made available under a Creative Commons license can be used according to the terms and conditions of said license. Use of all other works requires consent of the right holder (author or publisher) if not exempted from copyright protection by the applicable law.

(Article begins on next page)



UNIVERSITÀ DEGLI STUDI DI TORINO

*The final publication is available at Springer via*  
<http://link.springer.com/article/10.1007%2Fs12033-012-9533-8>

## **Alternative molecular tests for virological diagnosis**

Francesca Sidoti, Massimiliano Bergallo, Cristina Costa, Rossana Cavallo.

Virology Unit, Department of Public Health and Microbiology, University Hospital San Giovanni Battista di Torino, University of Turin, Italy.

### **Corresponding Author:**

Dr. Cristina Costa, MD

Virology Unit, Department of Public Health and Microbiology,

University Hospital San Giovanni Battista di Torino,

Via Santena 9 - 10126 Turin, Italy.

Phone: +39(11)6705630 - Fax +39(11)6705648

E-mail address: [cristina.costa@unito.it](mailto:cristina.costa@unito.it)

## **Abstract**

Several nucleic acid amplification techniques (NAATs), particularly PCR and real time PCR, are currently used in the routine clinical laboratories. Such approaches have allowed rapid diagnosis with a high degree of sensitivity and specificity. However, conventional PCR methods have several intrinsic disadvantages such as the requirement for temperature cycling apparatus, and sophisticated and costly analytical equipments. Therefore, amplification at a constant temperatures is an attractive alternative method to avoid these requirements. A new generation of isothermal amplification techniques are gaining a wide popularity as diagnostic tools due to their simple operation, rapid reaction and easy detection. The main isothermal methods reviewed here include loop-mediated isothermal amplification (LAMP), nucleic acid sequence-based amplification (NASBA), and helicase-dependent amplification (HDA). In this review, design criteria, potential of amplification, and application of these alternative molecular tests will be discussed and compared to conventional nucleic acid amplification techniques.

**Keywords:** LAMP, NASBA, HDA, isothermal amplification, virological diagnosis.

## Introduction

At present, a wide variety of diagnostic techniques are applied for the detection of viral pathogens. Traditional diagnostic methods, like virus isolation and serology, have been the mainstay of the clinical laboratory, especially in the past two decades. In recent years several previously unknown viral pathogens have been discovered for which classical culture is unrealized or even lacks sensitivity. To overcome the shortcomings of the traditional diagnostic methods, molecular techniques have been developed. Several nucleic acid amplification techniques (NAATs), particularly PCR and real time PCR, are currently used in the routine clinical laboratories. Such approaches have allowed rapid diagnosis with a high degree of sensitivity and specificity. Moreover, NAATs have offered additional advantages over traditional methods by production of easily standardized protocols, thus resulting a potential for automatization with a range of options for real time detection chemistries. The advent of fully automated systems with faster turnaround times has given clinical laboratories the tools necessary to report out accurate and sensitive results to clinicians. However, all these *in vitro* nucleic acid amplification methods have several intrinsic disadvantages, such as the requirement for precision thermal cycling between three temperatures during the reaction and an elaborate method for detection of amplified products. Moreover, real time-PCR machines are very expensive requiring an instrumentation platform that consists of a thermal cycler, computer, optics for fluorescence excitation, emission collection, data acquisition and analysis software. In this context, a new generation of isothermal amplification techniques are gaining a wide popularity as diagnostic tools due to their simple operation, rapid reaction and easy detection. These new techniques do not require thermal cycler and can be performed simply by using a heating block and/or water bath with a low-energy consumption. The main isothermal methods reviewed here include loop-mediated isothermal amplification (LAMP), nucleic acid sequence-based amplification (NASBA), and helicase-dependent amplification (HDA). Moreover, in this review, design criteria, potential of amplification, and application of these alternative molecular tests in the detection of viral pathogens will be discussed.

## **Loop-mediated isothermal amplification (LAMP)**

Loop-mediated isothermal amplification (LAMP) represents today a better innovative nucleic acid amplification method which exceeds the classical PCR in its reaction simplicity, accuracy, and higher amplification efficiency. The whole procedure is very rapid and the nucleic acid amplification can be completed in less than 1 hour under isothermal conditions. The main advantage of the LAMP technique is that it does not require thermocyclers and the amplification can be performed simply with a water bath or heating block necessary to maintain the required temperature. Moreover, the design of LAMP assay is very simple requiring only the DNA polymerase along with dNTPs, reaction buffer, and two sets of specially primers that can be developed using the free software Primer Explore (LAMP primer designing support software program, Net laboratory, Japan, <http://venus.netlaboratory.com>). The addition of reverse transcriptase make it possible to amplify cDNA from RNA sequences (RT-LAMP).

### **The LAMP method**

LAMP is an one-step amplification reaction that amplifies target DNA from a few copies to  $10^9$ - $10^{10}$  copies and proceeds at isothermal conditions for 1 hour or less depending on the efficiency of the designed primers. LAMP employs a DNA polymerase with strand displacement activity (*Bst* DNA polymerase), along with two internal primers (FIP, BIP), and two outer primers (F3, B3) which recognize six different sequences in the DNA template, by incubating all the reagents in a single tube at a constant temperature, usually 63 °C which is optimum for the activity of DNA polymerase (Fig. 1). The chemistry of LAMP amplification is based on the principle of strand displacement reaction which has been described thoroughly by Notomi and colleagues (*1*). In particular, the mechanism of the reaction can be explained in three steps, an initial non-cyclic step, a cyclic amplification step, and an elongation step. An animation that is useful for better understanding of the principle is available at the web site <http://loopamp.eiken.co.jp/e/index.html>. The addition of a

primer set that anneals at the loop structure in LAMP amplicons enhances specificity of the reaction and accelerates further the amplification time (2). In particular, using these specific primers, named loop-primers (LF, LB), the reaction time is reduced by half, making it a more efficient tool used in the practical applications of LAMP. Moreover, the employment of reverse transcriptase in addition to DNA polymerase allows the synthesis of cDNA molecules from RNA template. Reverse transcriptase is added to the reaction mixture and, after mixing and incubating at a constant temperature between 60-65 °C, amplification and detection can be carried out in a single step (RT-LAMP). As concerns the visualization of amplified product obtained from LAMP reaction, several methods may be used. Firstly, product is visualized by agarose gel analysis stained with an intercalating agent such as ethidium bromide or SYBR Green I using a common UV transilluminator. As the product of the LAMP is a mixture of different length DNA fragments, the gel will show several bands which will appear as a smear. Another method, based on real time turbidity measurement, allows to quantify the amount of DNA template formed by LAMP amplification. The increase of turbidity in the reaction mixture is directly proportional to the amount of DNA synthesized. Precisely, the LAMP method yields large amounts of pyrophosphate ions in the course of the amplification reaction leading to a white precipitate of insoluble magnesium pyrophosphate in the reaction mixture. Since the production of precipitate correlates with the increase of turbidity, real time monitoring of the LAMP reaction kinetics can be achieved by measurement of turbidity using an inexpensive turbidimeter. Gene copy number can also be quantified by using a standard curve obtained from different concentrations of gene copy number plotted against time of positivity. Finally, a new detection method of amplified products has been developed (3). This method uses fluorescent intercalating dye, like calcein, the fluorescence of which is quenched by the binding of manganese ions bound by pyrophosphate ions produced in the course of the amplification reaction. The presence of fluorescence indicates the presence of DNA template and a simple visual detection can be achieved by using an UV lamp. Recently, LAMP products have also been detected electrochemically in a microchip (4). Based on these assumptions, it is possible to make a number of considerations. LAMP as-

say is more specific towards the template sequences than classical PCR. This is caused because four primers recognize six separate regions within a target DNA and the amplification reaction occurs only when all these six regions are correctly recognized by the primers. Furthermore, LAMP is more sensitive than conventional DNA-based detection systems and its ability to amplify from fewer copies of initial target DNA than PCR has been demonstrated (5-8). In particular, the LAMP assay was found to be 10-100 fold more sensitive than PCR with a detection limit of 0.01-10 pfu of virus (9-11). The development of LAMP assay is very simple and allows the use of cost-effective reaction equipment. The simplicity of this method comes from the facility of designing primers and from the fact that only the DNA polymerase along with dNTPs, reaction buffer, and a common water bath or heating block are necessary for the development of LAMP assay. Moreover, LAMP has higher amplification efficiency compared with the PCR, with DNA being amplified  $10^9$ - $10^{10}$  times. This high amplification efficiency is attributed to no time loss of thermal change because of its isothermal reaction. Finally, RT-LAMP assay demonstrated faster in comparison to conventional RT-PCR (30 minutes *versus* 3-4 hours), because no additional reverse transcriptase step is required.

### **Applications of LAMP assay**

A survey of the literature shows that the LAMP has already been applied to detect many kinds of pathogens including viruses and bacteria (12-14). In particular, the LAMP method has been developed for most emerging human viral pathogens like West Nile, Dengue, Chikungunya, Japanese Encephalitis, SARS, highly pathogenic avian influenza (HPAI) H5N1, and Norwalk viruses (9-11,15-19). RT-LAMP assays for rapid detection of several respiratory viruses as influenza A and B virus, measles virus, and mumps virus have also been evaluated (20-24). Moreover, the usefulness of LAMP for amplification of DNA viruses was also reported for cytomegalovirus, herpes simplex virus, varicella zoster virus, human herpes virus 6-7, adenovirus, BK virus, and human papilloma virus type-6, 11, 16, 18 (25-36). The LAMP technology has now been developed into commercially available detection kits and some of them have been adopted as the officially recommended meth-



ods for detecting various pathogens. LAMP kits for the detection of *Escherichia coli*, *Mycobacterium*, *Salmonella*, *Legionella*, *Vibrio cholerae*, *Listeria*, *Campylobacter*, and *Cryptosporidium* have been commercialized (37-40). Considering the advantages of rapid amplification, and easy detection, the current focus of LAMP methodology is towards a simple diagnostic tool to be routinely employed in resource-limited laboratories in developing countries where many fatal tropical diseases are endemic, without requiring sophisticated equipment or skilled personnel. However, the combination of LAMP methodology and innovative microchip technologies may facilitate the realization of novel testing systems to be used by both developed and developing countries in the near future.

### **Nucleic acid sequence-based amplification (NASBA)**

Nucleic acid sequence-based amplification (NASBA) technology has provided an alternative method to conventional procedures with a broad application for the detection of several nucleic acid targets. In particular, NASBA is an isothermal transcription-based amplification method, first described by Guatelli and colleagues, particularly suitable for the detection and quantification of genomic, ribosomal, and messenger RNA (41). NASBA offers potential advantages compared to conventional RT-PCR. First of all, it is a continuous, isothermal process that does not require a thermocycler and the optimal annealing temperature for primers does not have to be determined empirically. Moreover, because NASBA is a method based on the isothermal reaction occurring at a temperature of 41 °C, and does not require denaturation, it prevents amplification of DNA genome in case of contamination, thus being very selective for RNA target amplification. However, the low temperature occurring in the reaction could be represent a risk factor for the specificity of the method. Anyhow, the specificity rate is increased by a well-constructed method for detecting amplified products using additional hybridization with target-specific probes. Another advantage is that no additional reverse transcriptase step is required, thus saving time and reducing the risk of contamina-

tion. The only restriction of NASBA method is probably that individual preparation of the chemical reagents mixture is difficult and commercial kits are expensive.

### **The NASBA method**

NASBA amplification consists of a repeated process of primer annealing, formation of double-stranded DNA molecule containing a T7 promoter site, and T7-RNA polymerase mediated transcription of multiple anti-sense copies of RNA amplicons (Fig. 2). Held at 41 °C, the reaction uses two oligonucleotide primers specific to the RNA target, P1 (forward primer), P2 (reverse primer), and three enzymes: avian myeloblastosis virus reverse transcriptase (AMV-RT) which has also polymerase activity, RNase H, and T7 RNA polymerase. During the reaction, a DNA intermediate is generated through a process that involves the hybridization of a primer to the RNA target. This primer (P1), which contains a T7 RNA polymerase promoter sequence, is then extended by AMV-RT to form a RNA-DNA hybrid. The digestion of the RNA component of the hybrid by RNase H permits the binding of a second primer (P2) to the remaining DNA strand. The second primer is then extended by AMV-RT to form the double-stranded DNA intermediate, which contains the T7-RNA polymerase promoter needed for transcription. Finally, the T7 RNA polymerase produces numerous RNA copies and once transcription is initiated, the resulting single-stranded RNA transcripts, which are anti-sense to the original RNA, can serve as a template to start a new amplification process. The amplification product of NASBA can be detected by liquid or gel-based probe-hybridisation assays, electrochemiluminescence, or microfluidic electrochemical detection (42-45). Recently, real time assays incorporating amplification and detection in a single step have been reported and applied to a wide range of targets. In particular, quantitative real time NASBA assays using molecular beacons have been developed and utilized for the detection and quantification of several RNA target in all published real time procedures whether for commercially available kits or for in-house diagnostic assays (46,47). These real time NASBA assays appear to be rapid (about 1.5 hour), specific and sensitive with RNA amplification and a target-specific fluorescent signal

achieved simultaneously in one tube with measurements obtained by using a simple fluorometer. Real time NASBA methodology seems to be a suitable alternative to other real time amplification techniques such as RT-PCR without the need for expensive thermocyclers.

### **NASBA kinetics**

Because NASBA amplification involves three separate enzymes with their own kinetic parameters, variability in every measurement is inevitable (48). Weusten et al. were the first to describe a mathematical model for RNA amplification of both target and internal calibrator RNA in a molecular beacon-based NASBA reaction to normalize enzyme efficiency differences between reactions (49). However, the description of this model did not include all of the essential parameters needed to operate the model. Consequently, analysis using this model requires software calibrated to each target and is commercially available for only a few specific targets. On the contrary, in our study an alternative method for normalizing NASBA data by using a simple time to positivity (TPP) calculation in the presence of an internal control that reduces the variability between replicates has been described (47). To date, the role of primers and KCl concentration for NASBA optimization has not been considered. NASBA is able to specifically amplify target RNA by using specific primers in the presence of KCl. Initially, the primers concentration is very high and is not rate limiting; relatively small amounts of primers are consumed in depletion of the initially present pool of RNA copies (linear phase of NASBA process). At some time point, the primers concentrations do become rate limiting and decline towards zero. At this time point, the DNA intermediate levels have reached their peak and RNA production proceeds at high speed. From now on the only reaction that can proceed is T7 RNA polymerase-mediated formation of RNA from the DNA intermediate templates. This time interval represents the second phase of NASBA process characterized by an exponential kinetics (Fig. 2). In our study, we evidenced for the first time that high concentrations of primers and KCl elongate the linear phase of NASBA process by shorting the exponential amplification; whereas, low concentrations of primers and KCl promote the exponential phase (47). In particular,

in our study we used relatively low concentrations of primers and KCl (0.3  $\mu$ M and 80 mM, respectively) to elongate the exponential phase of NASBA process, and accordingly, to minimize the reaction-to-reaction variation.

### **Applications of NASBA assay**

NASBA has proven to be a useful technique for the highly sensitive detection of several pathogens in clinical, environmental, and food samples including, in particular, different RNA viruses (Table 1). Although NASBA methods offer a powerful tools for molecular diagnosis, their sensitivity and specificity are limited by several factors. Amplification inhibitors and RNA integrity are the main cause of concern when preparing clinical specimens for NASBA. Efficiency of RNA extraction methods is determined by the RNA recovery rate and NASBA inhibitor reduction during RNA extraction. Many RNA commercial extraction methods have been tested for the reduction or removal of NASBA inhibitors. In particular, RNA extraction originally performed with phenol-chloroform has been widely replaced by the Boom method which is suitable for use in NASBA and reagents for this are commercially available (73). However, these methods are time consuming, labor intensive and susceptible to contamination. Lately, complete automatization was introduced performing RNA extraction within 20-40 minutes on high numbers of samples. Several studies showed that robotic automated sample preparation and the performance of the automated MagNaPure and the NucliSens extraction procedures (EasyMAG and miniMAG) were more consistently than manual techniques (74,75). As concerns the development of in-house real time NASBA assays, a commercial kit is available (“NucliSens EasyQ<sup>®</sup> Basic kit” ([BioMérieux]) (76). It contains the necessary reagents for NASBA amplification process including AMV-RT, RNase H, T7 RNA polymerase enzymes in the form of lyophilized spheres, the enzyme diluent that consists of sorbitol in aqueous solution, the reagent lyophilized spheres containing nucleotides, dithiothreitol, MgCl<sub>2</sub> with their diluent (TRIS/HCl, 45% DMSO), and KCl solution. The primers and specific probe are to be synthesized for each target. In particular, the design of primers and probe for NASBA can be performed using

the “Beacon Designer™” program developed by PREMIER Biosoft International ([www.premier-biosoft.com](http://www.premier-biosoft.com)), and the stability of predicted structure beacons can be analysed by using the European MFOLD server (<http://frontend.bioinfo.rpi.edu/applications/mfold/cgi-bin/dna-form1.cgi>). The amplification conditions for real time NASBA are generally constant, and optimization of conditions for each new assay can be simpler than RT-PCR. The concentration of enzymes is standardized and does not differ from assay to assay. The variable factors that have to be optimized are the KCl, primers and probes concentrations. In conclusion, NASBA is a simple and rapid alternative method to conventional procedures, and its isothermal nature and specificity for RNA *versus* DNA make it an important technique in RNA research and diagnostics.

### **Helicase-dependent amplification (HDA)**

Helicase-dependent amplification (HDA) is an isothermal amplification reaction inspired by the natural mechanism of the DNA replication fork. This new technology mimics DNA replication *in vivo* by using a DNA helicase to separate two complementary DNA strands (dsDNA) into each single-stranded templates for primers hybridization and subsequent extension by a DNA polymerase. As the DNA helicase unwinds double-stranded DNA enzymatically, the initial heat denaturation and subsequent thermocycling are not necessary, and the entire HDA reaction can be performed at a single uniform temperature. Thus, this alternative technique provides a useful tool to amplify DNA *in vitro* under isothermal conditions with a very simple reaction scheme.

#### **The HDA method**

The amplification scheme of the HDA method is shown in Fig. 3. In this method, double-stranded DNA is unwound enzymatically by a DNA helicase in the presence of chemical energy. The displaced DNA strands are stabilized by single-stranded DNA (ssDNA)-binding proteins (SSBs). In particular, these SSB proteins bind specifically to the single-stranded part of DNA in order to prevent reannealing of the complementary ssDNA templates and to protect them from degradation.

Two sequence-specific primers hybridize to the 3'-end of each ssDNA template, and a DNA polymerase extends the primers annealed to the templates to produce a dsDNA. The two newly synthesized dsDNAs are used as substrates by the DNA helicase, entering the next round of the reaction. Therefore, a simultaneous chain reaction proceeds resulting in exponential amplification of the selected target sequence. It has been reported that RNA target as well as DNA was also amplified and detected by HDA method followed by reverse transcription step (77,78). Initially, the HDA systems were developed using *Escherichia coli* UvrD helicase and T7 bacteriophage gp4 helicase. These current HDA systems will be briefly described in this review with consideration of the processivity and efficiency of DNA amplification.

#### **HDA system using *Escherichia coli* UvrD helicase**

The first HDA system for isothermal DNA amplification was developed by using *E. coli* UvrD DNA helicase (~82 kDa) along with a DNA polymerase, and two accessory proteins (SSBs): T4 gene 32 or RB 49 gene 32 proteins (79,80). Initially, *E. coli* UvrD helicase was chosen due to its ability to unwind blunt-end substrates (dsDNA) as well as nicked circular DNA (81). This HDA system mimics the *in vivo* DNA replication and is able to amplify several hundred base pairs of DNA with a detection limit ranging from 10 to 10<sup>3</sup> DNA copies in less than 1 hour (82,77,83,84). Moreover, to further improve the sensitivity and specificity of DNA amplification in the HDA reaction a very simple expedient as the use of thermostable UvrD helicase at an elevated temperatures (60-65 °C) was considered. However, the efficient amplification of long target sequences is not possible, probably due to the low processivity and limited speed of DNA synthesis by UvrD helicase. It has been reported that UvrD helicase has a limited speed (20 bp/s) and processivity (less than 100 bp per binding) (85,86). The performance of an HDA system may be further improved by testing different helicases. A new HDA system with high processivity and speed was developed by using the T7 bacteriophage gp4 helicase.

### **HDA system using T7 bacteriophage gp4 helicase (T7 bacteriophage replisome)**

The T7 bacteriophage replisome consists of four proteins necessary for amplification process: T7 gp4 helicase-primase, T7 gp5 DNA polymerase, T7 gp2.5 (SSB protein), and the processivity factor *E. coli* thioredoxin (*trx*) (**87,88**). The T7 gp4 helicase-primase is a hexameric protein composed by two subunits, the gp4A (~63 kDa) with both helicase and primase activities, and the gp4B (~56 kDa) with only helicase activity (**87,89,90**). In the T7 helicase-based HDA system, the helicase T7 gp4 unwinds the dsDNA at a rate of 300 bp/s with high processivity, whereas the primase domain of T7 gp4 produces the primers (**91**). In particular, this HDA system has been applied to amplify both long linear and circular ssDNA templates, and the primase activity of T7 gp4 allows for whole genomes to be amplified without the need for additional DNA primers (**92**). As concerns the T7 gp5 DNA polymerase activity itself is not processive, whereas together with the processivity factor *E. coli* thioredoxin (T7 gp5 DNA polymerase-*E. coli* thioredoxin complex), the speed and processivity are enhanced by up to >100 nt/s and >10 kb per binding, respectively (**93**). Recent progress in understanding the function of helicases has enabled researchers to use a helicase/polymerase pair (helicase/polymerase fusion complex) which can move in a coordinated way to further improve the speed and the processivity of HDA systems, allowing for the amplification of DNA fragments up to 2.3 kb compared to the original limit of 400 bp (**94**). Future experiments will be certainly directed towards improving the performance of HDA systems by testing several helicases/polymerases complex, and by optimizing the existing HDA systems.

### **Applications of HDA assay**

HDA assay has been used to detect several viruses in different clinical samples. In particular, Tang and colleagues developed an innovative isothermal amplification HDA with lateral flow to detect HIV-1 in human plasma, whereas Kim and colleagues developed a qualitative HDA method for the detection of herpes simplex virus (HSV) types 1 and 2 from genital lesions (**95,96**). Moreover, a novel one-tube isothermal reverse transcription-thermophilic helicase-dependent amplification (RT-

tHDA) system has been developed to detect RNA viruses, including enterovirus and ebola virus (77). Thermophilic HDA in combination with enzyme-linked immunosorbent assay was also used by Gill and colleagues for the detection of *Helicobacter pylori*. In addition, they also developed a colorimetric method to detect *H. pylori* by using isothermal helicase-dependent amplification and gold nanoparticle probes (97,83). Andresen *et al.* incorporated HDA on a microarray for quantitative detection of antibiotic-resistant pathogens *Neisseria gonorrhoeae* and *Staphylococcus aureus* (98). Microfluidic chips have also been developed for HDA at 62 °C for quantification of SARS cDNA (99). A fully integrated microfluidic device for DNA extraction and helicase-dependent amplification at 65 °C on samples containing live bacteria has been developed by Mahalanabis *et al.* This microfluidic device was the first to combine bacterial lysis, nucleic acid extraction, and DNA amplification on the same chip (100). Finally, Kivlehan and colleagues reported for the first time the utilization of a quantitative electrochemical method to monitor in real time the HDA of nucleic acids in less than 1 hour at a single constant temperature. The principle of detection consists of monitoring a decrease in the electrochemical current response of a reporter probe during the amplification process. The detection strategy is analogous to that of real time HDA assay. However, this innovative electrochemical method offers some advantages compared to conventional real time assays being potentially more robust, simpler, and less expensive (101). Isothermal HDA kits are currently available and commercially developed at BioHelix (Beverly, MA, USA). In conclusion, it is expected that more useful and simpler isothermal amplification techniques will be invented to be used for the detection of different pathogens.

## References

1. Notomi, T., Okayama, H., Masubuchi, H., Yonekawa, T., Watanabe, K., Amino, N., and Hase, T. (2000) Loop-mediated isothermal amplification of DNA. *Nucleic Acids Res.* 28, E63.



2. Nagamine, K., Hase, T., and Notomi, T. (2002) Accelerated reaction by loop mediated isothermal amplification using loop primers. *Mol. Cell. Prob.* 16, 223-229.
3. Tomita, N., Mori, Y., Kanda, H., and Notomi T. (2008) Loop-mediated isothermal amplification (LAMP) of gene sequences and simple visual detection of products. *Nat. Protoc.* 3, 877-882.
4. Nakamura, N., Fukuda, T., Nonen, S., Hashimoto, K., Azuma, J., and Gemma, N. (2010) Simple and accurate determination of CYP2D6 gene copy number by a loop-mediated isothermal amplification method and an electrochemical DNA chip. *Clin. Chim. Acta.* 411, 568-573.
5. Gunimaladevi, I., Kono, T., Venugopal, M. N., and Sakai, M. (2004) Detection of koi herpesvirus in common carp, *Cyprinus carpio* L., by loop-mediated isothermal amplification. *J. Fish Dis.* 27, 583-589.
6. Kono, T., Savan, R., Sakai, M., and Itami, T. (2004) Detection of white spot syndrome virus in shrimp by loop-mediated isothermal amplification. *J. Virol. Methods.* 115, 59-65.
7. Savan, R., Igarashi, A., Matsuoka, S., and Sakai, M. (2004) Sensitive and rapid detection of edwardsiellosis in fish by a loop-mediated isothermal amplification method. *Appl. Environ. Microbiol.* 70, 621-624.
8. Gunimaladevi, I., Kono, T., Lapatra, S. E., and Sakai, M. (2005) A loop mediated isothermal amplification (LAMP) method for detection of infectious hematopoietic necrosis virus (IHNV) in rainbow trout (*Oncorhynchus mykiss*). *Arch. Virol.* 150, 899-909.

9. Hong, T. C., Mai, Q. L., Cuong, D. V., Parida, M., Minekawa, H., Notomi, T., Hasebe, F., and Morita, K. (2004) Development and evaluation of a novel Loop mediated isothermal amplification (LAMP) method for rapid detection of SARS Corona virus. *J. Clin. Microbiol.* 42, 1956-1961.
10. Parida, M. M., Guillermo, P., Inoue, S., Hasebe, F., and Morita, K. (2004) Real-Time reverse transcription loop mediated isothermal amplification for rapid detection of West Nile Virus. *J. Clin. Microbiol.* 42, 257-263.
11. Parida, M. M., Horioke, K., Ishida, H., Dash, P. K., Saxena, P., Jana, A. M., Islam, M. A., Inoue, S., Hosaka, N., and Morita, K. (2005) Rapid detection and differentiation of dengue virus serotypes by a real-time reverse transcription-loop-mediated isothermal amplification assay. *J. Clin. Microbiol.* 43, 2895-2903.
12. Misawa, Y., Yoshida, A., Saito, R., Yoshida, H., Okuzumi, K., Ito, N., Okada, M., Moriya, K., and Koike, K. (2007) Application of loop-mediated isothermal amplification technique to rapid and direct detection of methicillin-resistant *Staphylococcus aureus* (MRSA) in blood cultures. *J. Infect. Chemother.* 13, 134-140.
13. Karanis, P., and Ongerth, J. E. (2009) LAMP – an emerging technology for the detection of water- and food-borne protozoan parasites. *Trends Parasitol.* 25, 498-499.
14. Mori, Y., and Notomi, T. (2009) Loop-mediated isothermal amplification (LAMP): a rapid, accurate, and cost-effective diagnostic method for infectious diseases. *J. Infect. Chemother.* 15, 62-69.

15. Fukuda, S., Takao, S., Kuwayama, M., Shimazu, Y., and Miyazaki, K. (2006) Rapid detection of norovirus from fecal specimens by real-time reverse transcription-loop-mediated isothermal amplification assay. *J. Clin. Microbiol.* 44, 1376-1381.
16. Imai, M., Ninomiya, A., and Minekawa, H. (2006) Rapid diagnosis of H5N1 avian influenza virus infection by newly developed influenza H5 hemagglutinin gene-specific loop-mediated isothermal amplification method. *Vaccine.* 24, 6679-6682.
17. Toriniwa, H., and Komiya, T. (2006) Rapid detection and quantification of Japanese encephalitis virus by real-time reverse transcription loop-mediated isothermal amplification. *Microbiol. Immunol.* 50, 379-387.
18. Parida, M. M., Santhosh, S. R., Dash, P. K., Tripathi, N. K., Lakshmi, V., Mamidi, N., Shrivastva, A., Gupta, N., Saxena, P., Babu, J. P., Rao, P. V., and Morita, K. (2007) Rapid and real-time detection of chikungunya virus by reverse transcription loop mediated isothermal amplification assay. *J. Clin. Microbiol.* 45, 351-357.
19. Parida, M. M., Santhosh, S. R., Dash, P. K., Tripathi, N. K., Saxena, P., Ambuj, S., Sahni, A. K., Lakshmana, Rao, P. V., and Morita, K. (2006) Development and evaluation of reverse transcription Loop mediated isothermal amplification assay for rapid and real-time detection of Japanese encephalitis virus. *J. Clin. Microbiol.* 44, 4172–4178.
20. Fujino, M., Yoshida, N., Yamaguchi, S., Hosaka, N., Ota, Y., Notomi, T., and Nakayama, T. (2005) A simple method for the detection of measles virus genome by loop-mediated isothermal amplification (LAMP). *J. Med. Virol.* 76, 406-413.

21. Okafuji, T., Yoshida, N., Fujino, M., Motegi, Y., Ihara, T., Ota, Y., Notomi, T., and Nakayama T. (2005) Rapid diagnostic method for detection of mumps virus genome by loop-mediated isothermal amplification. *J. Clin. Microbiol.* 43, 1625-1631.
22. Poon, L. L., Leung, C. S., Chan, K. H., Lee, J. H., Yuen, K. Y., Guan, Y., and Peiris, J. S. (2005) Detection of human influenza A viruses by loop-mediated isothermal amplification. *J. Clin. Microbiol.* 43, 427-430.
23. Ito, M., Watanabe, M., Nakagawa, N., Ihara, T., and Okuno, Y. (2006) Rapid detection and typing of influenza A and B by loop-mediated isothermal amplification: comparison with immunochromatography and virus isolation. *J. Virol. Methods.* 135, 272-275.
24. Yoshida, N., Fujino, M., Miyata, A., Nagai, T., Kamada, M., Sakiyama, H., Ihara, T., Kumagai, T., Okafuji, T., Okafuji, T., and Nakayama, T. (2008) Mumps virus reinfection is not a rare event confirmed by reverse transcription loop-mediated isothermal amplification. *J. Med. Virol.* 80, 517-523.
25. Ihira, M., Yoshikawa, T., Enomoto, Y., Akimoto, S., Ohashi, M., Suga, S., Nishimura, N., Ozaki, T., Nishiyama, Y., Notomi, T., Ohta, Y., and Asano, Y. (2004) Rapid diagnosis of human herpesvirus 6 infection by a novel DNA amplification method, loop-mediated isothermal amplification. *J. Clin. Microbiol.* 42, 140-145.
26. Okamoto, S., Yoshikawa, T., Ihira, M., Suzuki, K., Shimokata, K., Nishiyama, Y., and Asano, Y. (2004) Rapid detection of Varicella-zoster virus infection by a loop-mediated isothermal amplification method. *J. Med. Virol.* 74, 677-682.

27. Wakabayashi, T., Yamashita, R., Kakita, T., Kakita, M., and Oshika, T. (2004) Rapid and sensitive diagnosis of adenoviral keratoconjunctivitis by loop-mediated isothermal amplification (LAMP) method. *Curr. Eye Res.* 28, 445-450.
28. Yoshikawa, T., Ihira, M., and Akimoto, S. (2004) Detection of human herpesvirus 7 DNA by loop-mediated isothermal amplification. *J. Clin. Microbiol.* 42, 1348-1352.
29. Enomoto, Y., Yoshikawa, T., and Ihira, M. (2005) Rapid diagnosis of herpes simplex virus infection by a loop-mediated isothermal amplification method. *J. Clin. Microbiol.* 43, 951-955.
30. Kaneko, H., Iida, T., Aoki, K., Ohno, S., and Suzutani, T. (2005) Sensitive and rapid detection of herpes simplex virus and varicella-zoster virus DNA by loop-mediated isothermal amplification. *J. Clin. Microbiol.* 43, 3290-3296.
31. Sugiyama, H., Yoshikawa, T., Ihira, M., Enomoto, Y., Kawana, T., and Asano, Y. (2005) Comparison of loop-mediated isothermal amplification, real-time PCR, and virus isolation for the detection of herpes simplex virus in genital lesions. *J. Med. Virol.* 75, 583-587.
32. Suzuki, R., Yoshikawa, T., Ihira, M., Enomoto, Y., Inagaki, S., Matsumoto, K., Kato, K., Kudo, K., Kojima, S., and Asano, Y. (2006) Development of the loop-mediated isothermal amplification method for rapid detection of cytomegalovirus DNA. *J. Virol. Methods.* 132, 216-221.
33. Bista, B. R., Ishwad, C., Wadowsky, R. M., Manna, P., Randhawa, P. S., Gupta, G., Adhikari, M., Tyagi, R., Gasper, G., and Vats, A. (2007) Development of a loop-mediated isothermal amplification assay for rapid detection of BK virus. *J. Clin. Microbiol.* 45, 1581-1587.

34. Hagiwara, M., Sasaki, H., Matsuo, K., Honda, M., Kawase, M., and Nakagawa, H. (2007) Loop-mediated isothermal amplification method for detection of human papillomavirus type 6, 11, 16, and 18. *J. Med. Virol.* 79, 605-615.
35. Ihira, M., Akimoto, S., Miyake, F., Fujita, A., Sugata, K., Suga, S., Ohashi, M., Nishimura, N., Ozaki, T., Asano, Y., and Yoshikawa, T. (2007) Direct detection of human herpesvirus 6 DNA in serum by the loop-mediated isothermal amplification method. *J. Clin. Virol.* 39, 22-26.
36. Kuhara, T., Yoshikawa, T., Ihira, M., Watanabe, D., Tamada, Y., Katano, H., Asano, Y., and Matsumoto, Y. (2007) Rapid detection of human herpesvirus 8 DNA using loop-mediated isothermal amplification. *J. Virol. Methods.* 144, 79-85.
37. Annaka, T. (2003) Rapid and simple detection of *Legionella* species by LAMP, a new DNA amplification method. *Rinsho Biseibutshu Jinsoku Shindan Kenkyukai Shi.* 14, 25-30.
38. Iwamoto, T., Sonobe, T., and Hayashi, K. (2003) Loop-mediated isothermal amplification for direct detection of *Mycobacterium tuberculosis* complex, *M. avium*, and *M. intracellulare* in sputum samples. *J. Clin. Microbiol.* 41, 2616-2622.
39. Karanis, P., Thekisoe, O., Kiouptsi, K., Ongerth, J., Igarashi, I., and Inoue, N. (2007) Development and preliminary evaluation of a loop-mediated isothermal amplification procedure for sensitive detection of *cryptosporidium* oocysts in fecal and water samples. *Appl. Environ. Microbiol.* 73, 5660-5662.

40. Yamazaki, W., Seto, K., Taguchi, M., Ishibashi, M., and Inoue, K. (2008) Sensitive and rapid detection of cholera toxin-producing *Vibrio cholerae* using a loop-mediated isothermal amplification. *BMC Microbiol.* 8, 94.
41. Guatelli, J. C., Whitfield, K. M., Kwoh, D. Y., Barringer, K. J., Richman, D. D., and Gingeras, T. R. (1990) Isothermal, in vitro amplification of nucleic acids by a multienzyme reaction modeled after retroviral replication. *Proc. Natl. Acad. Sci. USA.* 87, 1874-1878.
42. Wu, S. L., Lee, E. M., Putvatana, R., Shurtliff, R. N., Porter, K. R., Suharyono, W., Watts, D. M., King, C. C., Murphy, G. S., Hayes, C. G., and Romano, J. W. (2001) Detection of dengue viral RNA using a nucleic acid sequence-based amplification assay. *J. Clin. Microbiol.* 39, 2794-2798.
43. Min, J., and Baeumner, A. J. (2002) Highly sensitive and specific detection of viable *Escherichia coli* in drinking water. *Anal. Biochem.* 303, 186-193.
44. Connelly, J. T., Nugen, S. R., Borejsza-Wysocki, W., Durst, R. A., Montagna, R. A., and Baeumner, A. J. (2008) Human pathogenic *Cryptosporidium* species bioanalytical detection method with single oocyst detection capability. *Anal. Bioanal. Chem.* 391, 487-495.
45. Nugen, S. R., Asiello, P. J., Connelly, J. T., and Baeumner, A. J. (2009) PMMA biosensor for nucleic acids with integrated mixer and electrochemical detection. *Biosens. Bioelectron.* 24, 2428-2433.
46. Schneider, P., Wolters, L., Schoone, G., Schallig, H., Sillekens, P., Hermsen, R., and Sauerwein, R. (2005) Real-time nucleic acid sequence-based amplification is more convenient

than real-time PCR for quantification of *Plasmodium falciparum*. *J. Clin. Microbiol.* 43, 402-405.

47. Sidoti, F., Bergallo, M., Terlizzi, M. E., Piasentin Alessio, E., Astegiano, S., Gasparini, G., and Cavallo, R. (2012) Development of a quantitative real-time nucleic acid sequence-based amplification assay with an internal control using molecular beacon probes for selective and sensitive detection of human rhinovirus serotypes. *Mol. Biotechnol.* 50, 221-228.

48. Patterson, S. S, Casper, E. T., Garcia-Rubio, L., Smith, M. C., and Paul, J. H 3rd. (2005) Increased precision of microbial RNA quantification using NASBA with an internal control. *J. Microbiol. Methods.* 60, 343-352.

49. Weusten, J. J., Carpay, W. M., Oosterlaken, T. A., van Zuijlen, M. C., and van de Wiel, P. A. (2002) Principles of quantitation of viral loads using nucleic acid sequence-based amplification in combination with homogeneous detection using molecular beacons. *Nucleic Acids Res.* 30, 6e26.

50. Van Doornum, G. J. J., Schutten, M., Voermans, J., Guldemeester, G. J. J., and Niesters, H. G. M. (2007) Development and implementation of Real time nucleic acid amplification for the detection of Enterovirus infections in comparison to rapid culture of various clinical specimens. *J. Med. Virol.* 79, 1868-1876.

51. Costa, A. M., Lamb, D., Garland, S. M., and Tabrizi, S. N. (2008) Evaluation of LightCycler as a platform for nucleic acid sequence-based amplification (NASBA) in real time detection of enterovirus. *Curr. Microbiol.* 56, 80-83.



52. Lau, L. T., Feng, H. Y., Lam, T. Y., Hui, H. K., and Yu, A. C. (2010) Development of multiplex nucleic acid sequence-based amplification for detection of human respiratory tract viruses. *J. Virol. Methods.* 168, 251-254
53. Moore, C., Hibbitts, S., Owen, N., Corden, S. A., Harrison, G., Fox, J., Gelder, C., and Westmoreland, D. (2004) Development and evaluation of a Real-time nucleic acid sequence based amplification assay for rapid detection of influenza A. *J. Med. Virol.* 74, 619-628.
54. Moore, C., Corden, S., Sinha, J., and Jones, R. (2008) Dry cotton or flocked respiratory swabs as simple collection technique for the molecular detection of respiratory viruses using real time NASBA. *J. Virol. Methods.* 153, 84-89.
55. Ge, Y., Cui, L., Shan, J., Shan, Y., Qi, Y., Wu, B., Wang, H., and Shi, Z. (2010) Detection of novel swine origin influenza A virus (H1N1) by real-time nucleic acid sequence-based amplification. *J. Virol. Methods.* 163, 495-497.
56. Moore, C., Telles, J. N., Corden, S., Gao, R. B., Vernet, G., Van Aarle, P., and Shu, Y. L. (2010) Development and validation of a commercial real time NASBA assay for the rapid confirmation of influenza AH5N1 virus in clinical samples. *J. Virol. Methods.* 170, 173-176.
57. Manji, R., Lotlikar, M., Zhang, F., and Ginocchio, C. C. (2009) Clinical evaluation of Nucli-sens magnetic extraction and nucli-sens analytical specific reagents for the real-time detection of respiratory syncytial virus (RSV) in pediatric respiratory specimens. *J. Clin. Microbiol.* 62, 998-1002.

58. van Gemen, B., van Beuningen, R., Nabbe, A., van Strijp, D., Jurriaans, S., Lens, P., and Kievits, T. (1994) A one-tube quantitative HIV-1 RNA NASBA nucleic acid amplification assay using electrochemiluminiscent (ECL) labelled probes. *J. Virol. Methods.* 49, 157-168.
59. Shepard, R. N., Schock, J., Robertson, K., Shugars, D. C., Dyer, J., Vernazza, P., Hall, C., Cohen, M. S., and Fiscus, S. A. (2000) Quantitation of human immunodeficiency virus type 1 RNA in different biological compartments. *J. Clin. Microbiol.* 38, 1414-1418.
60. de Baar, M. P., van Dooren, M. W., de Rooij, E., Bakker, M., van Gemen, B., Goudsmit, J., and de Ronde, A. (2001) Single rapid real-time monitored isothermal RNA amplification assay for quantification of human immunodeficiency virus type 1 isolates from groups M, N, and O. *J. Clin. Microbiol.* 39, 1378-1384.
61. Lamhoujeb, S., Fliss, I., Ngazoa, S. E., and Jean, J. (2008) Evaluation of the persistence of infectious human norovirus on food surfaces by using real time nucleic acid sequence-based amplification. *Appl. Environ. Microbiol.* 74, 3349-3355.
62. Dare, R., Sanghavi, S., Bullotta, A., Keightley, M. C., George, K. S., Wadowsky, R. M., Patterson, D. L., McCurry, K. R., Reinhart, T. A., Husain, S., and Rinaldo, C. R. (2006) Diagnosis of human metapneumovirus infection in immunosuppressed lung transplant recipients and children evaluated for pertussis. *J. Clin. Microbiol.* 45, 548-552.
63. Keightley, M. C., Sillekens, P., Schippers, W., Rinaldo, C., and George, K. S. (2005) Real time NASBA detection of SARS-associated coronavirus and comparison with real-time reverse transcription-PCR. *J. Med. Virol.* 77, 602-608.

64. Telles, J. N., Le Roux, K., Grivard, P., Vernet, G., and Michault, A. (2009) Evaluation of real time nucleic acid based amplification for detection of Chikungunya virus in clinical sample. *J. Med. Microbiol.* 58, 1168-1172.
65. Lanciotti, R. S., and Kerst, A. J. (2001) Nucleic acid sequence-based amplification assays for rapid detection of West Nile and St. Louis encephalitis viruses. *J. Clin. Microbiol.* 39, 4506-4513.
66. Wu, S. J., Lee, E. M., Putvatana, R., Shurtleff, R. N., Porter, K. R., Suharyono, W., Watts, D. M., King, C. C., Murphy, G. S., Hayes, C. G., and Romano, J. W. (2001) Detection of dengue viral RNA using nucleic acid sequence-based amplification assay. *J. Clin. Microbiol.* 39, 2794-2798.
67. Abd el-Galil, K. H., el-Sokkary, M. A., Kheira, S. M., Salazar, A. M., Yates, M. V., Chen, W., and Mulchandani, A. (2005) Real time nucleic acid sequence-based amplification assay for detection of hepatitis A virus. *Appl. Environ. Microbiol.* 71, 7113-7116.
68. Damen, M., Sillekens, P., Cuypers, H. T., Frantzen, I., and Melsert, R. (1999) Characterization of the quantitative HCV NASBA assay. *J. Virol. Methods.* 82, 45-54.
69. Guichon, A., Chiparelli, H., Martinez, A., Rodriguez Trento, A., Russi, J. C., and Carballal, G. (2004) Evaluation of a new NASBA assay for the detection of hepatitis C virus based on the Nuclisens basic kit reagents. *J. Clin. Virol.* 29, 84-91.
70. Loens, K., Goossens, H., de Laat, C., Foolen, H., Pattyn, S., Sillekens, P., and Ieven, M. (2006) Detection of rhinoviruses by tissue culture and two independent amplification techniques,

nucleic acid sequence-based amplification and reverse transcription-PCR, in children with acute respiratory infections during a winter season. *J. Clin. Microbiol.* 44, 166-171.

71. Chadwick, N., Bruce, I., Davies, M., van Gemen, B., Schukkink, R., Khan, K., Pounder, R., and Wakefield, A. (1998) A sensitive and robust method for measles RNA detection. *J. Virol. Methods.* 70, 59-70.

72. Wacharapluesadee, S., Phumesin, P., Supavonwong, P., Khawplod, P., Intarut, N., and Hemachudha, T. (2011) Comparative detection of rabies RNA by NASBA, real-time PCR and conventional PCR. *J. Virol. Methods.* (in press).

73. Boom, R., Sol, C. J., Salimans, M. M., Jansen, C. L., Wertheim-van Dillen, P. M., and van der Noordaa, J. (1990) Rapid and simple method for the purification of nucleic acids. *J. Clin. Microbiol.* 28, 495-503.

74. Wilson, D. A., Yen-Lieberman, B., Reischl, U., Warshawsky, I., and Procop, G. W. (2004) Comparison of five methods for extraction of *Legionella pneumophila* from respiratory specimens. *J. Clin. Microbiol.* 42, 5913-5916.

75. Loens, K., Bergs, K., Ursi, D., Goossens, H., and Ieven, M. (2007) Evaluation of NucliSens easyMAG for automated nucleic acid extraction from various clinical specimens. *J. Clin. Microbiol.* 45, 421-425.

76. Fox, J. D., Han, S., Samuelson, A., Zhang, Y. D., Neale, M. L., and Westmoreland D. (2002) Development and evaluation of nucleic acid sequence based amplification (NASBA) for diagnosis of enterovirus infections using the NucliSens® Basic Kit. *J. Clin. Virol.* 24, 117-130.

77. Goldmeyer, J., Kong, H., and Tang, W. (2007) Development of a novel one-tube isothermal reverse transcription thermophilic helicase-dependent amplification platform for rapid RNA detection. *J. Mol. Diagn.* 9, 639-644.
78. Andresen, D., von Nickisch-Rosenegk, M., and Bier, F. F. (2009) Helicase dependent On-Chip-amplification and its use in multiplex pathogen detection. *Clin. Chim. Acta.* 403, 244-248.
79. Casas-Finet, J. R., and Karpel, R. L. (1993) Bacteriophage T4 gene 32 protein: modulation of protein-nucleic acid and protein-protein association by structural domains. *Biochemistry.* 32, 9735-9744.
80. Desplats, C., Dez, C., Tetart, F., Eleaume, H., and Krisch, H. M. (2002) Snapshot of the genome of the pseudo-T-even bacteriophage RB49. *J. Bacteriol.* 184, 2789-2804.
81. Runyon, G. T., and Lohman, T. M. (1989) *Escherichia coli* helicase II (uvrD) protein can completely unwind fully duplex linear and nicked circular DNA. *J. Biol. Chem.* 264, 17502-17512.
82. An, L., Tang, W., Ranalli, T. A., Kim, H. J., Wytiaz, J., and Kong, H. (2005) Characterization of a thermostable UvrD helicase and its participation in helicase-dependent amplification. *J. Biol. Chem.* 280, 28952-28958.
83. Gill, P., Alvandi, A. H., Abdul-Tehrani, H., and Sadeghizadeh, M. (2008) Colorimetric detection of *Helicobacter pylori* DNA using isothermal helicase-dependent amplification and gold nanoparticle probes. *Diagn. Microbiol. Infect. Dis.* 62, 119-124.

84. Motré, A., Kong, R., and Li, Y. (2011) Improving isothermal DNA amplification speed for the rapid detection of *Mycobacterium tuberculosis*. *J. Microbiol. Methods*. 84, 343-345.
85. Ali, J. A., Maluf, N. K., and Lohman, T. M. (1999) An oligomeric form of *E. coli* UvrD is required for optimal helicase activity. *J. Mol. Biol.* 293, 815-834.
86. Vincent, M., Xu, Y., and Kong, H. (2004) Helicase-dependent isothermal DNA amplification. *EMBO Rep.* 5, 795–800.
87. Dunn, J. J., and Studier, F. W. (1983) Complete nucleotide sequence of bacteriophage T7 DNA and the locations of T7 genetic elements. *J. Mol. Biol.* 166, 477-535.
88. Richardson, C. C. (1983) Bacteriophage T7: minimal requirements for the replication of a duplex DNA molecule [Review]. *Cell*. 33, 315-317.
89. Bernstein, J. A., and Richardson, C. C. (1989) Characterization of the helicase and primase activities of the 63-kDa component of the bacteriophage T7 gene 4 protein. *J. Biol. Chem.* 264, 13066-13073.
90. Rosenberg, A. H., Patel, S. S., Johnson, K. A., and Studier, F. W. (1992) Cloning and expression of gene 4 of bacteriophage T7 and creation and analysis of T7 mutants lacking the 4A primase/helicase or the 4B helicase. *J. Biol. Chem.* 267, 15005-15012.
91. Kornberg, A., and Baker, T. (1992). *DNA replication*. 2<sup>nd</sup> edn, New York: WH Freeman and Company.

92. Matson, S. W., and Richardson, C. C. (1983) DNA-dependent nucleoside 5'-triphosphatase activity of the gene 4 protein of bacteriophage T7. *J. Biol. Chem.* 258, 14009-14016.
93. Tabor, S., Huber, H. E., and Richardson, C. C. (1987) *Escherichia coli* thioredoxin confers processivity on the DNA polymerase activity of the gene 5 protein of bacteriophage T7. *J. Biol. Chem.* 262, 16212-16223.
94. Jeong, Y. J., Park, K., and Kim, D. E. (2009) Isothermal DNA amplification in vitro: the helicase-dependent amplification system. *Cell. Mol. Life Sci.* 66, 3325-3336.
95. Tang, W., Chow, W. H. A., Li, Y., Kong, H., Tang, Y., and Lemieux, B. (2010) Nucleic acid assay system for tier II labs and moderately complex clinics to detect HIV in low-resource settings. *J. Infect Dis.* 201, S46-S51.
96. Kim, H. J., Tong, Y., Tang, W., Quimson, L., Cope, V. A., Pan, X., Motre, A., Kong, R., Hong, J., Kohn, D., Miller, N. S., Poulter, M. D., Kong, H., Tang, Y.W., and Yen-Lieberman, B. (2011) A rapid and simple isothermal nucleic acid amplification test for detection of herpes simplex virus types 1 and 2. *J. Clin. Virol.* 50, 26-30.
97. Gill, P., Amini, M., Ghaemi, A., Shokouhizadeh, L., Abdul-Tehrani, H., Karami, A., and Gilak, A. (2007) Detection of *Helicobacter pylori* by enzyme-linked immunosorbent assay of thermophilic helicase-dependent isothermal DNA amplification. *Diagn. Microbiol. Infect. Dis.* 59, 243-249.

98. Andresen, D., von Nickisch-Rosenegk, M., and Bier, F. F. (2009) Helicase-dependent amplification: use in OnChip amplification and potential for point-of-care diagnostics. *Expert Rev. Mol. Diagn.* 9, 645-650.
99. Ramalingam, N., Liu, H. B., Dai, C. C., Jiang, Y., Wang, H., Wang, Q. M., Hui, K., and Gong, H. Q. (2009) Real-time PCR array chip with capillary-driven sample loading and reactor sealing for point-of-care applications. *Biomed. Microdevices*. [Epub ahead of print].
100. Mahalanabis, M., Do, J., AlMuayad, H., Zhang, J. Y., and Klapperich C. M. (2011) An integrated disposable device for DNA extraction and helicase dependent amplification. *Bio-med. Microdevices*. 13, 599-602.
101. Kivlehan, F., Mavr e, F., Talini, L., Limoges B., and Marchal, D. (2011) Real-time electrochemical monitoring of isothermal helicase-dependent amplification of nucleic acids. *Analyst*. 136, 3635-3642.



**Figure 1.** Schematic representation of primer design for LAMP assay. The figure shows the position of six primers (FIP, BIP, F3, B3, Loop F, Loop B) spanning the target gene.

**Figure 2.** Schematic representation of NASBA process using molecular beacons probes as a detection system. The figure shows the two phases of the NASBA amplification process characterized by a linear and exponential kinetics.

**Figure 3.** Amplification scheme of HDA method. (Step 1) DNA helicase unwinds double-stranded DNA. (Step 2) SSB proteins stabilize the displaced DNA strands. (Step 3) Specific primers hybridize to the ssDNA template and are extended by DNA polymerase. (Step 4) A double-stranded copy of the DNA target is produced.

**Table 1.** Applications of NASBA assay in the detection of several RNA viruses.

<sup>a</sup>H1N1v, H1NI variant.

Figure 1.

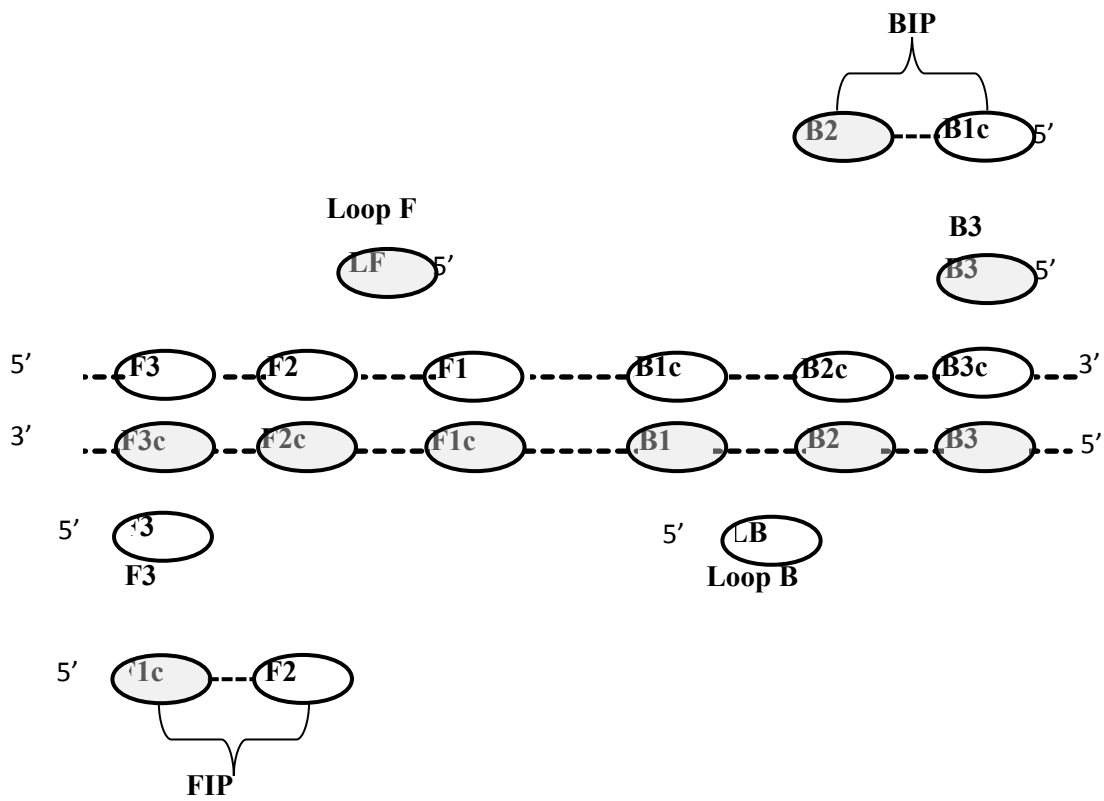

Figure 2.

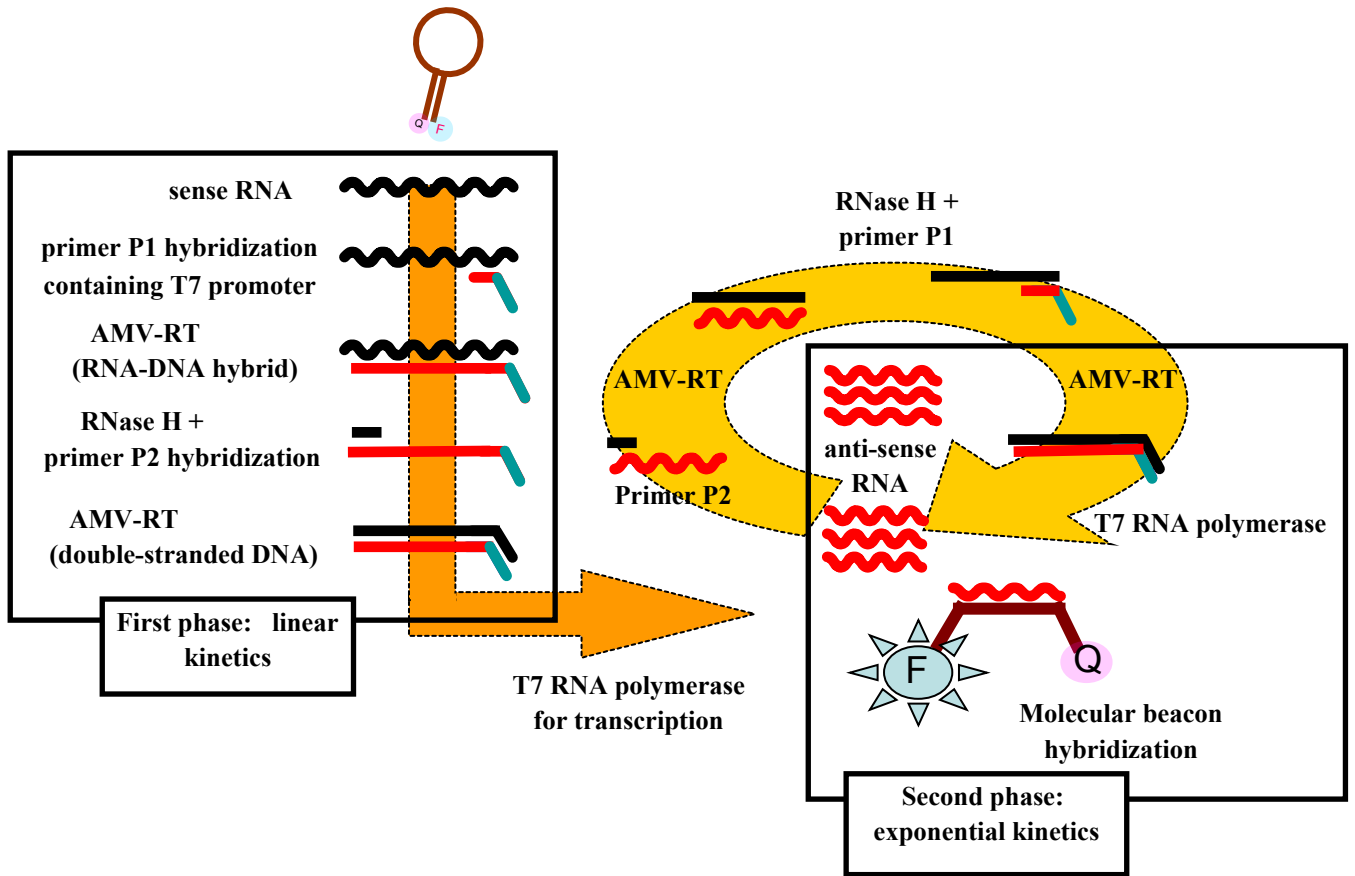
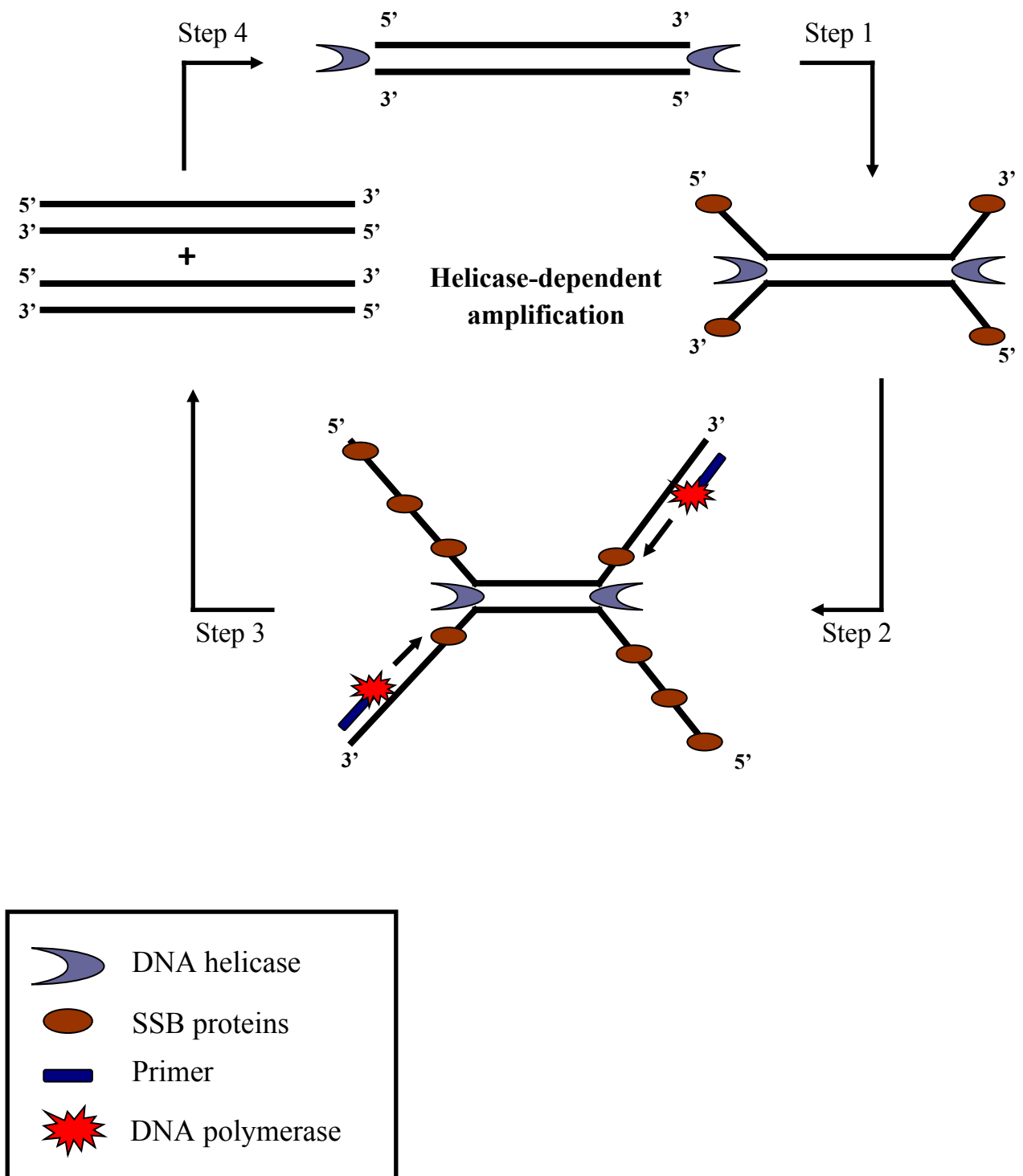

Figure 3.



**Table 1.**

<b>RNA viruses</b>	<b>Reference (s)</b>
Enterovirus	50-52
Influenza A virus	53,52
Influenza B virus	54,52
Influenza A virus (H1N1v) <sup>a</sup>	55
Influenza A virus (H5N1)	56
Respiratory syncytial virus	57,52
HIV-1	58-60
Parainfluenza virus type 1	52
Parainfluenza virus type 2	52
Parainfluenza virus type 3	52
Parainfluenza type 4	52
Norovirus	61
Metapneumovirus	62
SARS coronavirus (SARS-CoV)	63
Chikungunya virus	64
St. Louis Encephalitis virus	65
Dengue virus	66
West Nile virus	65
Hepatitis A virus	67
Hepatitis C virus	68,69
Human Rhinovirus	70,47
Measles virus	71
Rubella virus	52
Rabies virus	72