

Integrated water-energy modeling in TEMOA energy system optimization model: Pantelleria case study

Farzaneh Amir Kavei^{a,b}, Maria Elena Alfano^c, Matteo Nicoli^{a,b}, Francesco Quatraro^a, Laura Savoldi^{b,*} 

^a Department of Economics and Statistics “Cognetti de Martiis”, Università degli Studi di Torino, Italy

^b MAHTEP Group, Department of Energy “Galileo Ferraris”, Politecnico di Torino, Italy

^c Department of Environment, Land and Infrastructure Engineering, Politecnico di Torino, Italy

ARTICLE INFO

Keywords:

Energy system optimization models
TEMOA
Water-energy nexus
Open-source
Integrated energy - water ESOM
Pantelleria

ABSTRACT

This study addresses the limited integration of water-energy nexus dynamics in energy system models, particularly the lack of hard-linked modeling approaches. The aim is to develop and apply an integrated water-energy model using the open-source TEMOA framework, addressing the gap in quantifying reciprocal impacts of water and energy systems. The Island of Pantelleria serves as a case study due to its isolated infrastructure and ambitious decarbonization targets. First, a Reference Energy System is built and validated by comparing historical outcomes with past data and future projections with official transition scenarios. The model is then extended through the development of a detailed Reference Water System, incorporating water supply, treatment, and demand processes. Several scenarios are analyzed, including a zero-emission policy, reduction of water losses, increased in-situ water supply, and replacement of the primary wastewater treatment plant with a secondary one. Results show that the integrated model reveals substantial differences from the energy-only model. In particular, the ‘Clean Energy for EU Islands’ target indicates higher electricity consumption when water desalination is replaced by water import, an effect not captured by the energy-only model. Additionally, integrating fixed and variable components of water demand improved projection accuracy. The study concludes that a hard-linked water-energy modeling approach offers a more comprehensive understanding of the interdependencies between water and energy systems. This is crucial for planning effective, resource-efficient decarbonization strategies in isolated or resource-constrained contexts.

1. Introduction

Water is a fundamental resource, essential for life and crucial for almost all human activities, including agriculture, industry, and energy production [1]. However, while population, technology and economic growth increase the water demand [2], the impacts of climate change and resource-intensive economies [3] further escalate global pressure on water resources. Several powerful water system models, for instance, WEAP [4] or WRIMS [5], evaluate long-term water demand, supply, storage, reuse, resource pollution and abatement under different climate conditions and policy scenarios. These tools are intended to develop a broad spectrum of management and planning options. However, it is important to note that water is also tightly intertwined with energy, and this dependency is expected to intensify in the coming years [6]. On the other hand, energy, especially electricity, is vital for withdrawal,

treating and delivering water to the end-users. Several processes and technologies involved in the water supply chain, such as fresh and wastewater treatment, desalination or pumping, present some of the most urban energy-intensive processes [7]. Due to its features, water also plays numerous roles in the energy sector. It is present as a heat transfer fluid, working fluid, or directly in hydropower and fuel extraction [6]. Moreover, some renewable energies such as biofuels, carbon capture and storage technologies and flue gas desulfurization processes imply non-negligible water consumption [7].

Besides, climate change is severely affecting water resources and supply to such an extent that it is said to be “primarily a water crisis” [8]. Frequent and extreme floods compromise the quality of the water treatment facilities [9,10], increasing the risk of resource contamination, waterborne diseases and service disruptions. Droughts threaten human survival directly and indirectly through food scarcity and

* Corresponding author.

E-mail address: laura.savoldi@polito.it (L. Savoldi).

<https://doi.org/10.1016/j.nexus.2025.100461>

Received 25 October 2024; Received in revised form 9 May 2025; Accepted 16 May 2025

Available online 16 May 2025

2772-4271/© 2025 The Author(s). Published by Elsevier Ltd. This is an open access article under the CC BY-NC-ND license (<http://creativecommons.org/licenses/by-nc-nd/4.0/>).

hygiene issues, pushing towards the use of energy-intensive methods such as desalination or deep-pumping [8].

Energy System Optimization Models (ESOMs) are bottom-up frameworks widely used to study energy systems in the middle and long term. Thanks to their detailed and articulated technological inventory and economic parameters, they are used to evaluate the effectiveness and cost-competitiveness of possible energy policies. The solution to the optimization problem satisfies the final energy service demands by finding the optimal (cheapest) future evolution of the system, respecting all user-defined constraints.

In recent years, the recognition of the interconnectedness of energy, with water and land resources, is growing. Indeed, the dynamics and competitiveness of water and energy commodities are being incorporated into assessment tools to manage both resources more effectively. The allocation of the limited water and energy resources must also be based on site-specific features of both resources. Moreover, a bidirectional approach allows for the evaluation of the reciprocal impacts of resources on several factors such as supply and demands, transport, and distribution. It also leads to identifying synergies provided by efficient use, reuse [11] or sector coupling. Additionally, national and international strategies such as SDGs or energy transition policies, pointing to sustainable and inclusive growth, call for considering fair and equal distribution of all resources [12]. To this end, simultaneous and reciprocal study of all resources is necessary, and different approaches and frameworks are adopted to realize such a target.

One widely utilized coupling involves leveraging the interconnections between the WEAP (Water Evaluation and Planning System) and LEAP (Low Emissions Analysis Platform) models [13,14]. Another approach has involved the integration of existing digital spatial data to develop a Geographic Information Systems (GIS) model of current and projected water demands for thermoelectric power plants [15, 16]. study the impacts of land use change on energy, food and water resources and how land-use change affects emissions in China from 2011 to 2021. The nexus context is used by [1] to assess resource security and risk assessment. Moreover, the integrated modeling approach is used to find the opportunities to reach carbon neutrality in different sectors, such as transport [17] or residential [18] sectors. The carbon footprint of the water supply chain is evaluated through an integrated WEAP-LEAP model by [19].

As reported in Table 1, there are very limited experiments with integrated water-energy modeling in ESOMs. The nexus implementation in ESOMs is not a common practice, and the interactions and interdependencies of the energy system with other resources and agents are commonly neglected [20]. used the TIAM-FR model, from the TIMES-MARKAL [21] proprietary framework family, to study the water and energy nexus of the power and upstream sectors in the Middle East. Besides relying on a proprietary framework and focusing solely on the power sector, the geographic extension of the model inhibits a detailed analysis of the water demands. Furthermore, such an extension results in the exclusion of the site-specific characteristics of water and energy resources, which are highly determining in both cases.

Nexus studies are also performed in open-source frameworks such as OSeMOSYS. For instance [23], deals with the optimal water-energy planning of Favignana Island, Italy. Also in this case, the water demand is considered to be unchanged over the modeling time horizon. An introductory work done by [26] deals with the methodology description of the Climate-Land-Energy-Water implementation in the OSeMOSYS. The demand-side of the model [26] includes three aggregated domestic, public & commercial and industrial final demands without any further disaggregation. In other studies by [22] and [27], two open-source tools, namely TEMOA and GRAPS are soft-linked to analysis the interconnection between water and power system, performing a seasonal co-optimization of a water reservoir in the US which simultaneously generates electricity in a hydropower plant and works as the heat sink of a conventional power plant. Once again, that work focuses on the energy aspects of water without performing a direct linking and addressing

Table 1

Summary of literature review on nexus implementation and integrated modeling in different frameworks.

Reference	ESOM Framework	Nexus Implementation	Spatial Coverage	Framework Type
Agrawal et al. (2018) [19]	Not ESOM-based (LEAP and WEAP)	Integrating Water Supply and Carbon Footprint Assessment	Regional	Proprietary
Boretti & Rosa (2019) [2]	Not ESOM-based	Water Demand Analysis	Global	
Carter (2017) [7]	Not ESOM-based	Energy Use in the Water Sector	Regional	
DeAmorim et al. (2018) [1]	TIAM	Water-Energy-Food Nexus	Global	Open-source
DeNooyer et al. (2015) [15]	Not ESOM-based	Quantifying Water Withdrawals of Thermoelectric Generation	Regional	
Dubreuil et al. (2013) [20]	TIAM-FR	Water-Energy Nexus in the Middle East	Regional	Open-source
Ford et al. (2022) [22]	TEMOA-GRASP	Co-Optimization of Reservoir and Power Systems	Local	Open-source
Groppi et al. (2023) [23]	OSeMOSYS	Small Island Water-Energy Planning	Local	Open-source
Huo et al. (2024) [18]	Not ESOM-based	Ah hoc model (CPSIAM) to study the decarbonization of the residential sector	Regional	
Li et al. (2024) [16]	Not ESOM-based	Water-Energy-Food nexus, effect of decarbonization on land use change	Country	
Mosso et al. (2024) [24]	TEMOA	Land Use Potential in Energy System Models	Local	Open-source
Polido et al. (2016) [25]	Not ESOM-based	SEA in European Small Islands	Local	
Ramos et al. (2022) [26]	OSeMOSYS	CLEW Implementation Methodology		Open-source
Shao et al. (2023) [17]	Not ESOM-based	Transport decarbonization opportunities assessment by integrated modeling	Country	
Xuan et al. (2020) [27]	TEMOA-GRASP	Co-Optimization of Reservoir and Power Systems	Local	Open-source

other issues of the water system per se. [28] utilized TEMOA to assess the impact of energy storage on decarbonization scenarios in Italy, highlighting the model's adaptability in capturing both short-term (hourly) energy dynamics and long-term trends. Similarly [29], applied TEMOA to develop a metric for evaluating the security of power, storage, hydrogen, and transport technologies in scenarios where raw material availability is constrained, using Italy as a case study.

Another implementation of the TEMOA framework is presented by [24], who introduced an Energy-Land Nexus methodology and evaluated the trade-offs between PV deployment and alternative land uses,

considering land availability, location, and cost, as demonstrated in the case of Pantelleria Island, Italy. Despite these advancements, a fully integrated, hard-linked Water-Energy Nexus within the TEMOA framework remains absent in the literature.

The novelty of this work lies in the development of a fully integrated modeling framework that simultaneously represents both energy and water systems within a single tool. Unlike soft-linking approaches commonly found in the literature, this hard-linked model enables a more comprehensive analysis of the interactions and synergies between the two systems. Using the open-source TEMOA model and focusing on the Italian island of Pantelleria as a case study, the framework is applied to explore future scenarios, including zero-emission pathways, with particular attention to water losses and reuse.

The usefulness of small-scale integrated models, and particularly the present model, is multiple. As decarbonization strategies require careful assessment of the resources, regional models offer a unique advantage in identifying local anthropogenic or natural features which affect the availability and productivity of certain energy and water resources [30]. Furthermore, being tailored for a specific area provides stakeholders, either from academics or decision-makers, with an adequate tool to analyze both water and energy dynamics and their interactions in a long-term energy planning context for a case study characterized by isolated water and energy systems and criticality of water resources [31]. In addition, in the framework of the CE4EUI project [32], Pantelleria Island is selected as a pilot island for the energy transition. Subsequently, the island Energy Transition Agenda [33] drafted in 2020 aims for total decarbonization by 2050. Rather than solely evaluating the regulatory frameworks, the present tool analyzes these scenarios together with their water impact, establishing more resilient strategies [34]. In fact, the effectiveness of transition plans requires evaluation of techno-economic requirements in a local context as suggested by [35]. Given these premises, Pantelleria was considered to be an appropriate case study to develop the integrated water energy model. The case study was also chosen because of a simplified energy system structure in order to be a pilot for the methodology development. Despite being focused on a specific case study, the RWS construction and coupling methodology are adaptable to other contexts. Furthermore, the adopted scenarios hold relevance for broader cases besides the present one.

The rest of the paper is structured as follows: Section 2 presents the proposed energy and water systems integrating approach (Section 2.1) and specifies the features of the Pantelleria model in different subsections of Section 2.2. In Section 2.3, the implemented scenarios related to power sector decarbonization, water pipeline improvements and wastewater plant substitution are discussed. Section 3 presents validation of the energy-only model with available data and includes a discussion of the outcomes of the implemented scenarios. Finally, Section 4 concludes the work by summarizing the achieved objectives and outlining the limitations and prospects.

2. Methodology

This section provides the methodology to develop a hard-linked integrated water-energy system in the TEMOA framework, including: the identification, modeling and validation of the Reference Energy System (RES), identification and modeling of the Reference Water System (RWS), and linking them to establish integrated water and energy systems. In Section 2.1, the TEMOA framework is briefly presented, and the general modeling approach is described. The case study is introduced, and the method is then contextualized and applied to it in Section 2.2. The section also includes the characterization processes and assumptions around the constituting elements of the RWS of Pantelleria Island. Finally, Section 2.3 is dedicated to the presentation of the implemented scenarios.

2.1. The adopted framework and integrated modeling approach

The adopted framework in this study is the TEMOA open-source ESOM. Among the open ESOMs, the bottom-up models OSeMOSYS (Open-Source Energy Modeling System) [36] and TEMOA (Tools for Energy Model Optimization and Analysis) [37] are the most used and well-recognized ones. The ability of open frameworks and more specifically TEMOA, with respect to the conventional ones, to model energy systems in different spatial and temporal scales is well-established. For instance [38], showed that TEMOA is as reliable as its analogue proprietary tool, i.e., TIMES. Indeed, open-source frameworks are used to assess the energy sectors across the world. Besides the usual long-term planning purposes, TEMOA is employed for more advanced tasks: [39] compared the effectiveness of two energy policies, namely energy efficiency and taxation, by introducing non-linearity in the objective function of the model. This framework has also been used to enhance renewable resource modeling by incorporating uncertainty and stochastic analysis [40,41].

ESOMs are based on the definition of a Reference Energy System (RES), which encompasses all sectors and technologies involved in the import, extraction, transformation, transmission (supply side), and consumption (demand side) of energy vectors, called otherwise commodities (see Fig. 1). The first year of the model time horizon is referred to as the "base year". Based on the model's objectives and the developer's preferences, the time horizon is further split into milestone years. In an ESOM, both the supply (power and upstream¹ sectors) and the demand sides (buildings, transport, industry, and agriculture sectors) of the RES are represented in a techno-economically detailed way [37], for instance by their efficiencies, life spans and their installation, fixed and variable costs. The model's sectors include several technologies linked with each other through primary or secondary energy commodity flows such as diesel fuel, electricity, or heat.

When a technology reaches the end of its lifespan gets substituted by new processes, typically resulting in efficiency improvements and investment costs for the system. The demand for energy services in the energy optimization models is exogenously defined and depends on its specific driver and elasticity. Among the final service demands, for instance, of the residential sector, cooking, space heating, or lightning can be mentioned. After the model is solved, for every milestone year, the demand is met by technology and fuel mix with the least cost of production. This mix also respects constraints defined by environmental (such as limits on emissions) or energy-driven (for instance, use of

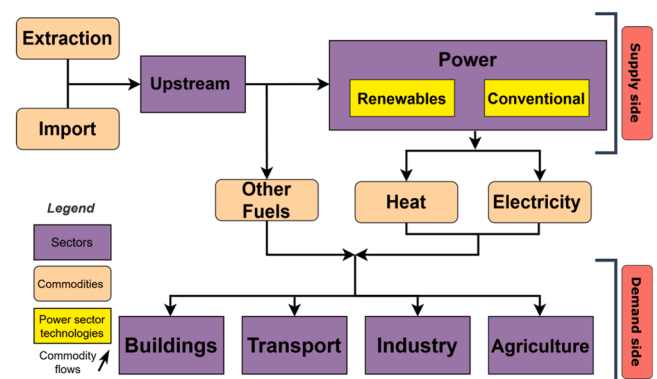

Fig. 1. General structure of the Reference Energy System in an ESOM.

¹ It is important to differentiate between the conventional usage of the term "upstream" in the context of water sector jargon and its application in this work. In this study, the term "upstream" is employed in Energy System Modeling usage and refers to the supply side of both water and energy commodities.

specific fuel) boundary conditions or policies [42,43]. For more details about Energy System Optimization Models and TEMOA structure, one can refer to the TEMOA introductory paper [37]. The main technoeconomic and characterization modeling factors of an ESOM are listed in Table 2.

Similarly to the RES, a module representing the Reference Water System (RWS) (see Fig. 2), with both supply and demand sectors referring to the RES base year, is defined. Indeed, RWS contains all the elements related to the supply and demand processes of the water system. The supply side of the water system consists of the upstream and the treatment sectors. The former involves all water harvesting methods from conventional to non-conventional resources, such as aquifers, reservoirs or desalination plants. The non-conventional water resources encompass various technologies for treating fresh water and wastewater to meet drinking standards or specific requirements of different end-uses.

Among the components of RWS, getting more attention in recent years, are Wastewater Treatment Plants (WWTPs). Besides their environmental importance, the hydrological pressures on the water resources intensified by climate change make wastewater treatment a feasible, accessible, and even necessary solution to supply water, as long as human, animal, environmental and natural safety are guaranteed. Moreover, WWTPs can be coupled with different parts of the energy sector, such as power-to-X or syngas production [44]. Note, however, that WWTPs are considered to be one of the energy-intensive appliances in the urban energy system [45]. The most energy-demanding process in these plants is the aeration, which accounts for a significant share of total energy consumption, ranging from 60 % to 75 % [46]. Besides, adopting advanced treatment techniques to improve the quality of the effluent for further uses will additionally increase the plant energy demand [47]. These characteristics make WWTPs of significant interest, particularly in the context of implementing the circular economy as suggested by [48].

To create the link between the two modules, it is necessary to identify the connection points that simultaneously use both water and energy commodities. These points are function of the structure of the RES and RWS in the studied case include technologies common to both systems. The connection creation requires an update of the efficiency (e.g., total flow of output commodities over the total flow of input commodities) of the interested technologies. Moreover, updating other key techno-economic parameters (such as capacity-to-activity, shares of input and output commodities respectively “TechInputSplits” and “TechOutputSplit”, maximum and minimum activities, etc.) should be carefully performed. This approach ensures that the methodology can be effectively extended to other cases. A general representation of the

Table 2
Main parameters used to characterize and constrain the different technologies in a bottom-up ESOM.

Category	Description	
Techno-economic parameters	Efficiency	
	Existing capacity	
	Lifetime	
	Capacity to activity	
	Capacity factors	
	Demands	
	Fixed O&M cost	
	Variable O&M cost	
	Investment cost	
	Discount rate	
	Constraints	Minimum capacity
		Maximum capacity
Minimum activity		
Maximum activity		
Share of input commodity for single technologies or technology groups		
Share of output commodity for single technologies or technology groups		

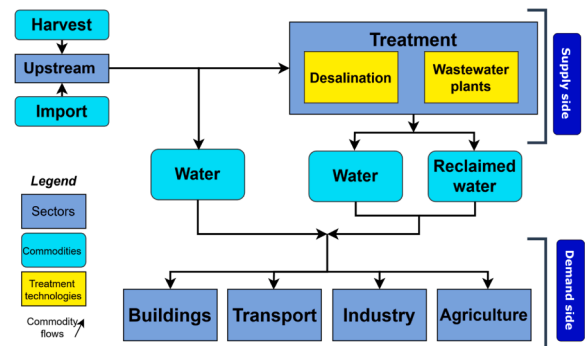

Fig. 2. General structure of the Reference Water System proposed in this work.

potential connection points of RES and RWS is visible in Fig. 3. As mentioned, the connecting points vary according to the specific case study and can lie in different sectors, such as upstream (e.g., desalination plants), power sector (e.g., conventional power plants using water for cooling or processes) or demand side sectors such as residential (e.g., water heating technologies).

2.2. Pantelleria case study

The selected case study for the development of the integrated water energy model is the Italian island of Pantelleria, visible in Fig. 4. Pantelleria is a volcanic island with a surface of 84.5 (km²). The island is 110 (km) far from Sicily, the largest Italian island [49]. In 2019, Pantelleria had around 7700 inhabitants.

The island is a popular tourist destination [33], resulting in highly seasonal trends in water and energy demands. Major economic activities include tourism-related sectors and agriculture, earning the island recognition as a human agricultural heritage site since 2014 [49]. The main agricultural activities are wine and caper, with approximately 15,000 hectares per year of grapes and 1000 hectares per year of capers [33]. The energy system of the island, like that of most Mediterranean islands, is isolated and relies on a diesel power plant. The potable water is supplied through imports from Italy’s mainland and two desalination plants.

Different reasons led to the choice of Pantelleria as case study. First, islands, especially small ones, represent an important resource for the European Union in terms of energy transition, environmental potential and biodiversity [25]. However, as reported by the IPCC [50], these territories suffer more profoundly from the consequences of climate change. In these areas, extreme events are most frequent [25] and have the greatest impacts: heat waves, drought, and sea level rise threaten them and cause more serious effects than on the mainland. Additionally, due to the natural isolation, the islands are often characterized by high transportation costs, isolated and most of the time fossil fuel-based energy systems, water scarcity and very limited economic diversification [51].

The Pantelleria-specific RES was developed following the layout of the Island’s energy system in 2013, taken as the base year. The base year was chosen due to the data availability and the possibility of obtaining historical trends [52]. The time horizon of the model comprises 13 milestone years, namely 2014, 2015, 2016, 2017, 2018, 2020, 2022, 2025, 2030, 2035, 2040, 2045 and 2050. The detailed description of the structure of the RES, together with the techno-economic characteristics of the sectors of the model, are presented and discussed in [53].

In the model, all interactions of Pantelleria with the mainland (Italy) are considered through import parameters (as the island does not have any type of extraction). In 2013, the energy upstream sector was composed of the importation of diesel, gasoline and LPG. Considering the additional cost of transportation, the fuel price has been considered 25 % higher than the Italian average value, consistent with the Energy

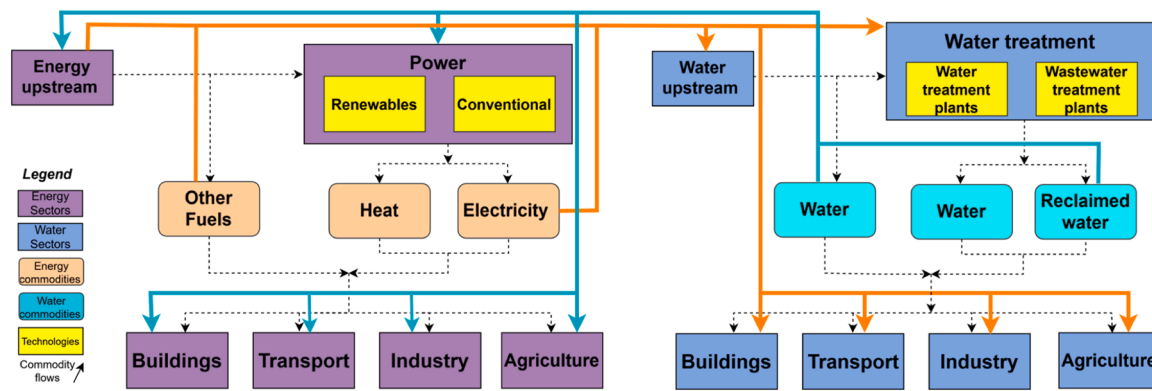

Fig. 3. Integration points in RES and RWS outlined in the present work.

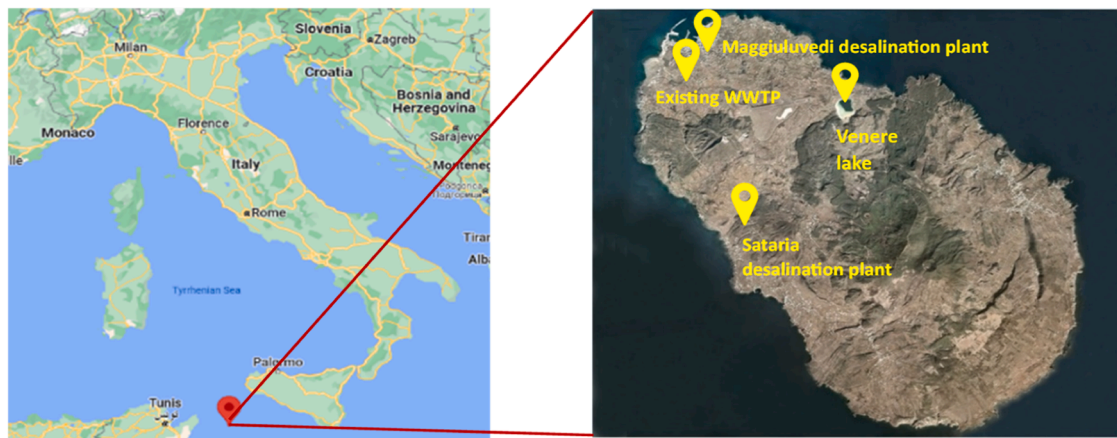

Fig. 4. Pantelleria Island location on Italy’s map on the left, and its main water sector points on the right.

Transition Agenda [33]. Gasoline is attributed only to the transport sector, LPG to meet the cooking demand, while diesel is assumed to be used for both transport and electricity production demands.

As mentioned, Pantelleria power sector is not connected with the mainland and is strongly fossil fuel dependent. The power sector in the base year was composed of a diesel power plant and a few distributed photovoltaic panels. The diesel plant with a total installed capacity of 22 MW consists of six diesel-fired steam units and two diesel gas turbines. The photovoltaic-rated capacity was about 140 (kW) [52]. Pantelleria has one of the highest and most diverse renewable energy potentials in Italy [33], which should be considered in its transition policies. The renewable resources of the island comprise solar, wind, geothermal, wave, and biomass. In 2013, only a very small fraction of solar potential was exploited. Resource availability is considered through constraints of the natural potential of renewable energy sources. The conventional and renewable plants are characterized by different sets of parameters such as efficiencies and their improvements throughout the lifetime, base year installed capacities, fixed, operational and maintenance costs, activity and capacity constraints, etc.

Considering the absence of industrial hubs, the demand side involves buildings (in turn composed of residential, commercial, and agriculture), transport and water production sectors. In the case of the RES including industrial activities, water use needs to be assessed. Based on the activity and the adopted technology, the specific water uses should be quantified, and a potential connection will be defined through the efficiency and other technical parameters of that specific technology. The methodology is discussed further for the water pipelines and WWTP, and can be extended to other technologies.

The demands are modelled starting from the available data on the

energy consumption of end-uses. Dealing with an energy system module, the water production sector (corresponding to the desalination plant) could be exclusively modelled as an energy-intensive technology and through its consumed energy. The demand for the desalination plant in the energy module is associated with a single driver accounting for the evolution of the tourism trends [54].

The RWS of Pantelleria Island is shown in Fig. 5. The upstream sector consists of conventional and non-conventional water sources, including rain, seawater desalination and imported water. Due to the permeable volcanic structure of the island [55], there is no groundwater extraction. Concerning the superficial water, there exists a single saline volcanic lake called “Lago di Venere” [56] placed in a natural reserve (visible in Fig. 4).

2.2.1. Primary water sources

To estimate the potential rainfall in 2013, the monthly average rainfall (shown in Table 3) has been considered [57]. Knowing the data in mm, an indicative volume (m³) of available water from rainfall has been estimated. To estimate the real rainwater availability for agricultural purposes, the effective seeped rainwater is to be assessed, in principle, by a complete hydrogeological balance. However, to simplify the rainwater-soil dynamics at the current state of the TEMOA-Pantelleria RWS, only the infiltration coefficient depending on the soil geology is accounted for. Considering the volcanic origin of Pantelleria [58], an infiltration coefficient equal to 0.9 [59] has been used to adjust the annual rainwater volume. Although this assumption may be acceptable for this specific context, it does not consider surface runoff processes that can occur even in permeable soils, particularly during high-intensity rainfalls or saturated conditions. Therefore, when

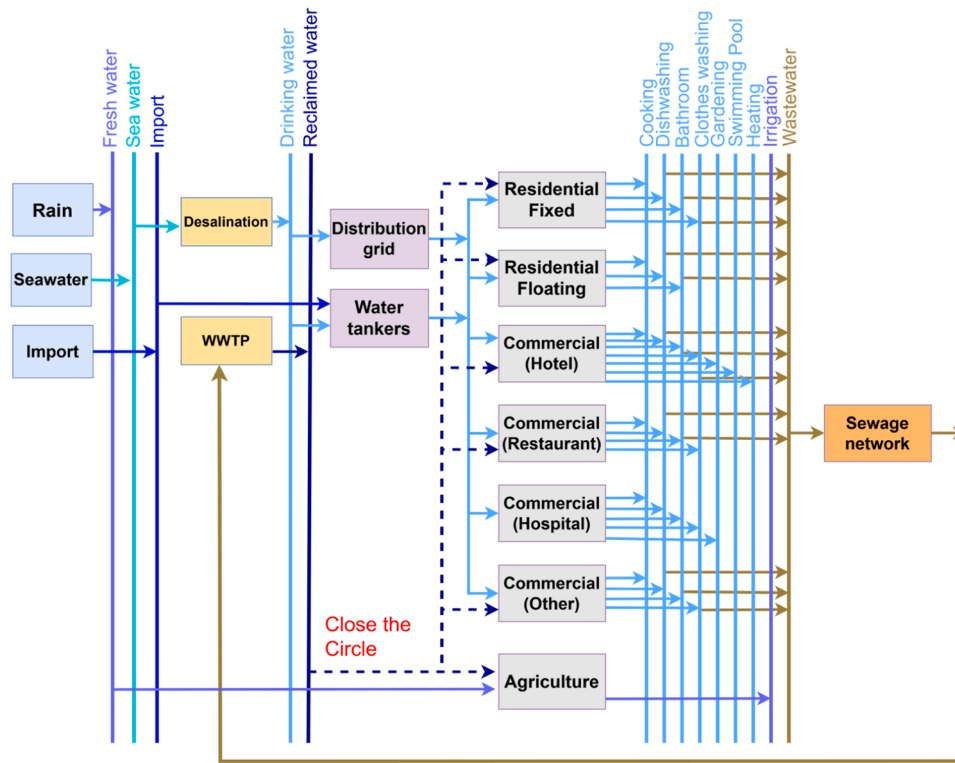

Fig. 5. Reference Water System of Pantelleria island.

Table 3
Average monthly rain considered for the Pantelleria case study.

Average monthly rainfall data (mm)												
Jan	Feb	Mar	Apr	May	Jun	Jul	Aug	Sept	Oct	Nov	Dec	
42.8	36.8	32.2	27.9	15.4	7.0	3.5	8.7	36.2	47.8	47.0	47.0	

applying the TEMOA model to other regions with different hydrologic and soil characteristics, it is necessary to use an appropriate infiltration coefficient. To account for the rainfall variation throughout the year and based on seasonal rainfall patterns, capacity factors of 32 %, 14 %, 14 %, and 40 %, respectively, for winter, spring, summer, and fall are assigned. The precipitation is derived from historical records [57], and in the absence of future forecasts, is assumed to be constant in future years. However, a limitation of this study is the lack of a climate model that accounts for potential changes due to climate change.

The only available data regarding water imports - approximately 1 million cubic meters, dating back to 2011 [60]- is assumed to be constant and is used as the base year value. Note that, according to the technical reports [54], in that year, the desalinated water was not sufficient to meet the summer water demand peak due to the tourist population. The import price, approximately 2.5 (€/m³), has been assigned considering the transport prices [61] and the sale price of water per m³ of the company ‘Sicilia Acque’ in 2010 [62].

Seawater is the most available resource and the most exploited water supply method of Pantelleria, which, in terms of uptake volumes, does not imply quantitative constraints. Consequently, the biggest part of the water is provided through the two desalination plants placed in the districts of Maggiuluedi and Sataria (shown in Fig. 4). In 2013, the Maggiuluedi plant was characterized by two desalination units. The first was equipped with Electrodialysis Reversal (EDR) and the second was based on Reverse Osmosis (RO) technology [54]. The EDR was composed of two parallel lines with a rated capacity of 450 (m³/d) each, while the RO modulus had a total capacity of 120 (m³/d). The Sataria plant consisted of two evaporative modules with Mechanical steam

Compression (MC), each with a nominal capacity of 1600 (m³/d) [54]. The input commodities of the desalination plants are electricity and seawater. The energy consumption of EDR technology is about 3.3 (kWh/m³), while for the MC plant, it is around 19 (kWh/m³). Electricity in the RWS module, i.e., the module, including only water, is defined as an ‘ethos’² commodity as it is perceived solely as a primary source rather than being obtained through a production process. The two desalination plants produce the same output commodity -the treated water- which is then pumped into the water pipelines. In 2015, the EDR and MC technologies were replaced by Reverse Osmosis (RO). Moreover, the plant capacity has increased by five modules, reaching a potential of 1300 (m³/d) each. The introduction of the new technology had advantages both in energy savings (for the MC plant) and in economic terms [63]. As a result of this upgrade, since 2015, energy consumption at the Sataria (MC technology substituted with RO) has been reduced by 80 %. The technological parameters by which the desalination plants were modelled are shown in Table 4.

² Fictitious initialization of a commodity since TEMOA needs always an input for the technologies. Other examples include extraction of fossil fuels, import commodities or renewable energy sources.

³ As in CE4EUI the energy mix is presented in percentages, the results are reported coherently.

⁴ The presented results cover the period from 2022 to 2050, reflecting the relevant timeframe for analysis. It is important to note that the identical outcome across the three models in 2022 are attributed to the historical trend.

Table 4
Parameters used to define the Pantelleria water treatment sector within the TEMOA framework.

Modeling parameters – desalination plants						
Technology	Energy consumption (kWh/m ³)	Rated capacity (m ³)	Technology lifetime (years)	Variable cost (€/m ³)	Investment cost (€/m ³)	Fixed cost (€/m ³)
MC desalination technology	19	1.17 × 10 ⁶	20	3.5 × 10 ⁻²		1.42
EDR desalination technology	3.3	3.29 × 10 ⁵	20	3.5 × 10 ⁻²		8.7 × 10 ⁻¹
Reverse Osmosis (RO)	3.5	3.87 × 10 ⁶	25	3.5 × 10 ⁻²	4.5 × 10 ⁻¹	2.3 × 10 ⁻¹

2.2.2. Water distribution system

The water distribution network, composed of conveyance systems, storage tanks, and pumping systems, is modelled as a single technology. All characteristic parameters of the water distribution system of the island are reported in Table 5.

In the water distribution system, the proper modeling of the losses is of paramount importance. In general, two types of losses need to be considered: hydraulic losses and leakages due to the ageing of pipelines. Hydraulic losses, concentrated and distributed, are considered in sizing the pumping system. In order to consider the Physical Losses (PL) due to ageing, the output water is calculated by Eq. (1), where PL is a coefficient representing water leakages. The physical losses have been imposed equal to 0.5, the mean value associated with the island in the Italian Statistics Agency (ISTAT) report [64].

$$Water_{output} = Water_{input} * PL \tag{1}$$

The pumping system, which is part of the hydraulic system, required an electricity input of around 1000 MWh in 2013. Therefore, the input commodities of the technology presenting the distribution grid in the model include treated water and electricity.

To account for the different shares of electricity and water entering into and exiting from the distribution system, a pseudo efficiency using Eq. (2) is calculated, where ELC_{TOT} is the electricity used by the water pipelines, UP_{TW} is the input water to the conveyance, and TW is the water output from the pipelines. The efficiency set for the base year within the model has been reported in Table 5.

$$Efficiency = \frac{TW}{(ELC_{TOT} + UP_{TW})} \tag{2}$$

Eq. (2) allows for consideration of both water losses and the proportion between the two input commodities. However, it should be noted that, like WWTP, it does not represent a proper efficiency because it is not dimensionless.

Table 5
Characteristics of the main elements of the water distribution network of Pantelleria in 2013.

Physical Losses		
0.5		
Water distribution system		
Total length (km)	60	
Base year pseudo-efficiency ($\frac{m^3}{m^3 + MWh}$)	0.49	
Storage system		
Total capacity (m ³)	2500	
Pumping system parameters		
System	Flow rate (m3/s)	Power (kW)
Sataria - Kaffefi	0.42	250
Sataria - Scauri	0.24	10
Scauri - Sataria	0.09	7.5
Kaffefi - Gelfiser	0.40	86
Gelfiser - ex Vedetta	0.24	18.5
Maggiulivedi - Arenella	0.08	22
Maggiulivedi - Kuddia	0.24	22
S. Elmo - S. Anna/Mursia	0.25	18.5

2.2.3. Water end-uses

The water demand-side sectors (left-hand side of Fig. 5) are structured and aligned with those of the energy system, but considering specific water-related sub-services. The water demand subsectors and their relative requirement (m³) are summarised in Table 6. No data on actual water consumption in Pantelleria for 2013 has been found, therefore, the base year water demand has been estimated based on the drinking water requirements for each user type [60]. The long-term projection of the final water demands, similar to the final energy demands, relies on specific drivers influencing water uses. Further subdivision of the water subsectors to end-uses and the drivers allocated to them can be seen in Table 7. Details regarding the fractional end-use shares across various demand sectors are provided in [53].

As mentioned, one fundamental aspect of Pantelleria is its fluctuating demands. Thus, to obtain a true-to-reality future water demand projection, it is essential to take into account the resident (fixed) and seasonal population (fluctuating) and adequate allocation of the associated drivers. To capture this fluctuating trend, a demand distribution with seasonal shares of 6 % for winter, 61 % for summer, 23 % for spring, and 10 % for autumn [65] has been set. The assumption that the tourism distribution follows the average of past trends is based on historical data [66]. In the absence of additional information, we assumed that this distribution remains consistent over time. Regarding the number of tourists, an annual increase was assumed, matching the historical growth rate observed in recent years, until reaching the island's capacity saturation.

2.2.4. Wastewater treatment plants

Another block of the RWS is the Wastewater Treatment Plant (WWTP). As of today, Pantelleria Island lacks an efficient wastewater treatment system [67]. According to a report by the Sicilian Regional Agency for Environmental Protection [68], there is currently only one active wastewater treatment plant on the island. The plant adopts **primary treatment** with a peak load of 9900 People Equivalent (P.E.) and a base load of 5900 (P.E.) [69]. The treated wastewater is discharged into the sea. The specific energy consumption of the existing plant has been taken referring to [70] by considering energy consumption for pumping, screening, and grit removal. The fixed and variable costs of the plant (reported in Table 9) have been calculated based on the methodology proposed by [71], which uses a linear model, a function of the plant treatment level (primary, secondary...) and its capacity (P.E.) to determine the cumulative costs. It is necessary to note that the proposed cost function in [71] is completely adaptable to other WWTPs types. In case the costs refer to different years, they need to be updated using the inflation coefficients specific to the studied RES and the reference year. The obtained cost is then decomposed into variable and fixed components based on [46]. Materials and energy costs, accounting for 6 % of the total cost [46], are then subtracted from the overall costs, the former because a primary plant does not have chemical treatments, and the latter being subject to the optimization process of the model. Costs are updated from the publication year of the paper, 2003, into two arbitrary milestone years, 2014 and 2019, according to the conversion coefficient published by the Italian Statistics Agency, ISTAT [72]. As mentioned before, being a primary facility, energy consumption and variable costs

Table 6
Daily and yearly water requirement [60].

Subsectors	Utilization time (days)	Daily water requirements (unit)	Daily requirement (m3)	Yearly requirement (m3)
Fixed population	365	250 (l/person)	1936	7.07×10^5
Seasonal population & swimming pools	90	250 (l/person)	2110	1.90×10^5
Hotels	365	250 (l/person)	416	1.52×10^5
Restaurants	365	100 (l/m2)	323	1.18×10^5
Bar	365	100 (l/m2)	100	3.65×10^4
Offices	365	130 (l/person)	26	9.49×10^3
Schools	270	80 (l/person)	103	2.78×10^4
Military barracks	365	160 (l/person)	24	8.76×10^3
Hospitals	365	700 (l/person)	70	2.56×10^4
Agriculture	60	2500 (l/m3 of wine)	1250	7.50×10^4
Others	365	200 (l/person)	34	1.24×10^4

Table 7
RWS end-use water demands along with their associated drivers for the Pantelleria case study.

Demand sector	End-uses	Driver
Residential (Fixed)	Cooking	Resident population
	Dishwashing	
	Clothes washing	
	Bathroom	
Residential (Floating)	Gardening	Seasonal population
	Cooking	
	Dishwashing	
Commercial (Hotel)	Bathroom	Resident population
	Cooking	
	Dishwashing	
	Bathroom (utility drain/shower)	
	Washing clothes	
	Gardening	
	Swimming pool	
	Heating	
Commercial (Restaurant)	Cooking	Resident population
	Dish washing	
	Bathroom (utility drain/shower)	
Commercial (Hospital)	Cooking	Resident population
	Dish washing	
	Bathroom (utility drain/shower)	
	Washing clothes	
Commercial (Other)	Gardening	Resident population
	Offices – schools – military barracks	
Agriculture	Agriculture water demand	Agriculture added value

of the existing WWTP are relatively negligible. To model the variation of the WWTP input flow due to the seasonal population change, the wastewater inlet has been decomposed into two fixed and floating parts, following the population trends. A summary of the WWTP modeling factors is reported in Table 8 and the second column of Table 9.

The wastewater entering the existing plant is quantified by subtracting the agriculture and hospital shares and assuming a 5 % sewage loss [73].

The existing plant is assumed to be substituted in 2025 (at its life

Table 8
Factors used to characterize the existing WWTP of Pantelleria.

Factor	Value	Unit
Residential water consumption	0.2	(m3/day)
Tourists water consumption	0.4	(m3/day)
Fixed population in 2021	7407	
Max tourist presence in 2019	26,350	
Tourists' peak presence growth rate 2018–2019	15	%
Min tourist presence in 2019	2070	
Tourists' min. presence growth rate 2018–2019	30	%

Table 9
Parameters to characterize the new WWTP of Pantelleria, together with some other characteristics of existing and new WWTPs.

Factor	Existing plant	New plant	Unit
BOD ₅	212.5		(g/m3)
Plant lifespan		30	(years)
Peak load	9900	85,000	(P.E.)
Base load	5900	8500	(P.E.)
Energy consumption	0.04	0.13	(kWh/m3)
Wastewater input	8.1×10^5	1.5×10^6	(m3)
Capacity to activity	91.25		(m3/P.E.)
Fixed cost (respectively, 2019 and 2025)	0.25	0.98	(€/m3)
Variable cost (respectively, 2019 and 2025)	0.02	0.12	(€/m3)

ends). A **secondary wastewater treatment** plant with nitrogen removal and filtration units conforming to the water reuse directive requirements [74] was modelled. These factors are manifesting through the costs of the plant. The new WWTP is characterized by its capacity (People Equivalent, P.E.), specific energy consumption (kWh/P.E.), capacity to activity factor (m³/P.E.), activity (m³), different investments, variable and fixed costs, and lifespan [75] as explained in the following. Moreover, the plant is characterized by a pseudo-efficiency calculated using Eq. (3).

$$Pseudo\ Efficiency\ of\ WWTP = \frac{Sludge\ [m^3] + Treated\ WW\ [m^3]}{Electricity\ [GWh] + WW\ [m^3]} \quad (3)$$

It is important to note that this equation serves for the model to account for the overall output. The input ratios of water or energy and reutilization are defined through another parameter, namely “TechInputSplit”, which determines the shares of the input commodities of a technology it is defined for. For technologies representing specific final use (e.g., agriculture) with water reuse, an input ratio (for instance, 5 %) of the reclaimed water on the total consumed water is defined. Similarly, “TechOutputSplit” is used to determine the ratios among the commodities produced by a technology.

Eq. (4) shows the relation between the “TechInputSplit” for a generic technology *t* (see Fig. 6) and one of its input commodities *i*, where *Flow_{in,i}* represents the consumption of the *i*th commodity by technology

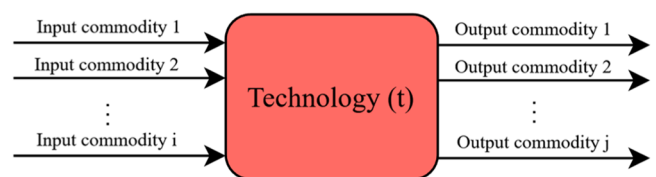

Fig. 6. A generic technology (t) and its respective input (i) and output (j) commodities.

t. Similarly, the same equation can be used to define TechOutputSplit, with the difference that the commodities in this case are those existing a certain technology.

$$TechInputSplit_{t,i} = \frac{Flow_{m,t,i}}{\sum_i Flow_{m,t,i}} \quad (4)$$

In the case of technology representing the water consumption, there are two input commodities, one regarding the normal water, set to have 95 % of the input share and the other, reclaimed water, accounts for the remaining 5 % of the input.

The peak load of the new plant is calculated considering both resident and tourist populations. The resident population is assumed to be unchanged and equal to that of 2021, although the statistics show a slight decrease in recent years [76]. The maximum number of tourists is calculated based on the peak presence number in 2019 [77] with a 15 % growth, derived from the growth rate between 2018 and 2019 [77]. Assuming infrastructure saturation, this increase is applied until 2025, after which no further growth is projected.

To project the volume of the wastewater entering the new plant in the future years, the total yearly water entering the WWTP is calculated as the weighted average of the residence and tourist populations in 2025, and their respective daily water usages taken respectively from [73] and [66]. As mentioned before, due to infrastructural limits, fluctuating populations are assumed to reach a steady state in 2025. The BOD_5 level of wastewater is taken as the average of the reported values

in [78]. These assumptions led to a required peak capacity of 85,000 (P.E.) for the new WWTP (see Table 9).

Two factors affecting dramatically the energy consumption of the WWTPs are their geographic location and their size [79]. A wide range of values is reported in the literature for these factors. In the present work, the adopted specific energy consumption is taken from [79], in which small and medium-sized WWTPs situated in Greece are investigated. Considering the size and geographic position of the case study, it is a reasonable choice. The investment cost of the plant has been taken from the local data relative to a 45,000 (P.E.) plant inaugurated in Cefalù, Sicily, in 2022 [80]. This value is updated for 2025, considering inflation coefficients as explained before for the plant costs updating [72].

The variable and fixed costs are calculated following the cost function used for the existing plant [71], but for a secondary plant with nutrients (N and P) removal technologies, excluding again the energy costs as explained before. In the model, the treatment level of the plant manifests through the higher installation and variable costs of the additional units to the plant.

The lifetime of the new plant is taken from [71,81], and the total treated wastewater in 2025 is calculated assuming a 1.3 % increase [82], subtracting also, in this case, the agriculture and hospital shares, assumed to be same as those of 2013 [73]. As these two portions are related to the resident population, such an assumption sounds reasonable. All the characteristics of the new WWTPs are shown in the third column of Table 9.

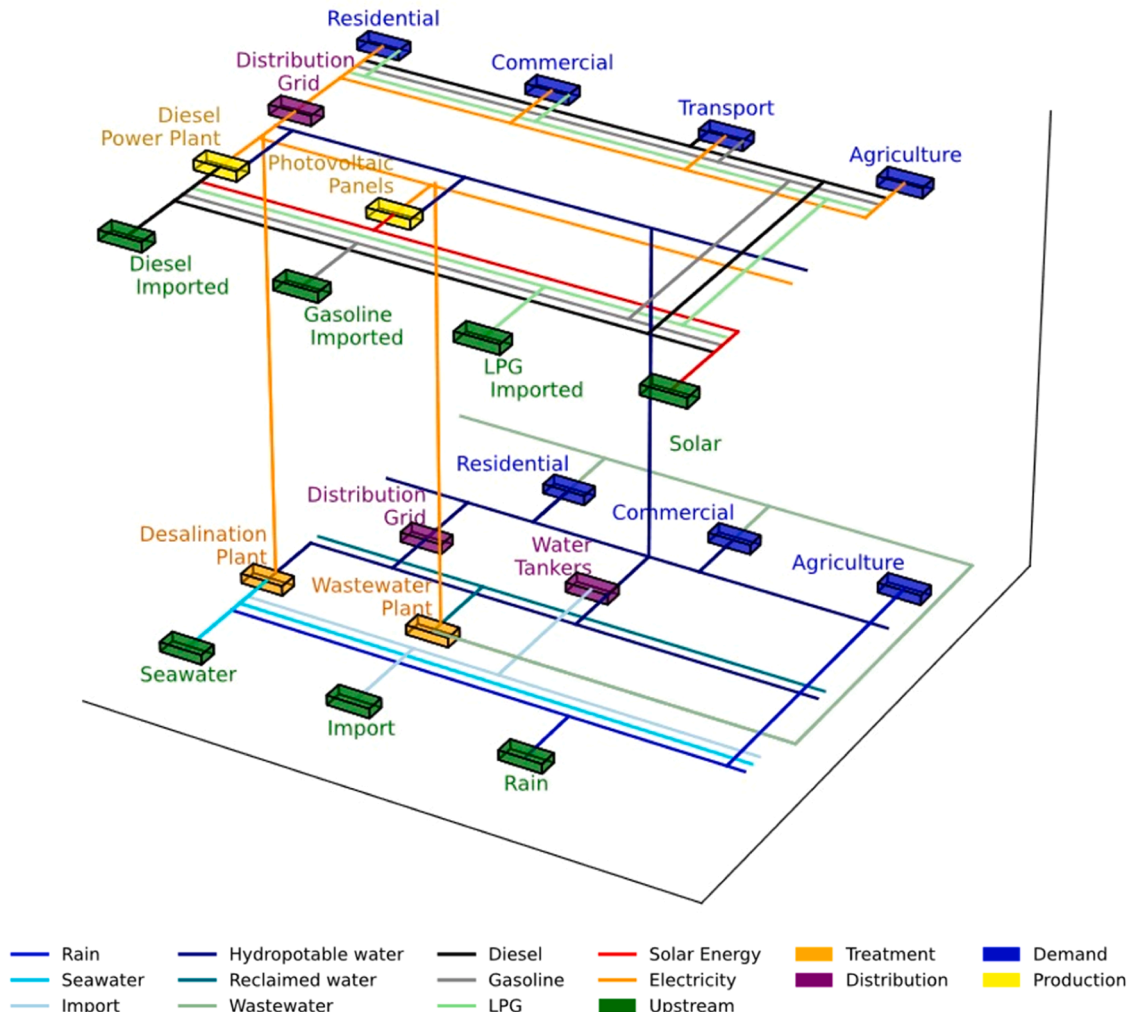

Fig. 7. The integrated energy-water system developed for Pantelleria.

2.2.5. Integration of RES and RWS

Once the case study specific RES and RWS are explained, it is possible to define the connection point between the two modules. The integrated RES-RWS can be thought of as two parallel water and energy layers connected at some points (see Fig. 7). As mentioned before, the connections are established via technologies communicating through energy and water commodities (i.e., power plant, desalination plants, WWTPs and water pipelines). Part of the electricity generated by the energy module is utilized to meet the energy demands of the water facilities, which, in turn, generates water commodity used in different sectors and technologies.

In fact, for Pantelleria, the connection points are predominantly within the water sector technologies and include water treatment, distribution, and wastewater. More specifically, energy consumption is associated with desalination plants, the pumping system and the WWTPs. As for the connections related to energy production technologies, that is, the water utilization in the diesel power plant, and to clean the photovoltaic panels, these can be neglected due to the restricted water consumption. Particularly, the cooling water for the diesel plant, as indicated in the company's technical reports [83], is directly supplied through a closed-loop seawater pumping system. Moreover, there is no evidence of the water used for PV cleaning. In addition, because of the volcanic soil of the island and the mainly rain-fed cultivations as mentioned previously, underground water exploitation and recovery of the agricultural water are not assumed.

2.3. Scenarios definition

To assess the validity of the energy-only model for the island of Pantelleria (Water Supply modeled in Energy only System - WSES), a Business-As-Usual (**WSES-BAU**) scenario has first been implemented. This scenario simulates the evolution of the energy system based on its current state. In essence, no constraints have been imposed on the transition of renewable energy or the electrification of the sector. Thus, the demand evolution is associated only with drivers and elasticity relative to energy commodities (for more details, refer to [53]).

Subsequently, within the same energy-only model, and in the light of the island's energy transition agenda [33], a Net Zero Emission (**WSES-NZE**) scenario is defined, which involves the renewable transition and electrification of the transportation, residential and commercial sectors. This transition is implemented by substituting the diesel power plant with totally renewable energy resources and establishing their maximum capacity by 2050, as mentioned, referring to the island energy transition agenda [33]. In TEMOA, these constraints are set as maximum limits rather than minimum requirements. This approach allows the model to optimize freely among all available technologies without being constrained to specific substitutions. It does not explicitly prioritize milestone years, specific technologies, or renewable energy share targets. However, for consistency with [24], a constraint was introduced to ensure that electricity generation comes entirely from renewable sources by 2035.

As a comparison, the decarbonization scenario applied by the Clean Energy for EU Islands agenda (CE4EUI) [32] has been reported (Table 10). This scenario imposes specific renewable penetration targets for key years, sectors and technologies. As in the scenarios implemented in the energy module, i.e., **WSES (WSES-BAU and WSES-NZE)**, the water supply system and its evolutions are modeled solely from the energy point of view. Consequently, the water demands projections cannot be as articulated as the integrated module.

After implementing the integrated model, and in order to evaluate the evolution of the system up to 2050, other scenarios are proposed. It is important noting that all the scenarios implemented in the integrated model take the energy transition [84] as the target. These scenarios are implemented to investigate energy-water interconnection. Such interdependence in the integrated model is becoming even more relevant as the water demand increases as a result of being modeled independently

Table 10

Comparison of the constraints imposed on the Business as usual, NZE and CE4EUI scenarios. EV stands for electric vehicles.

Scenario-specific Goals (%)					
Scenario	Year	Electric Vehicles (%)		Renewable Energy Sources (%)	
WSES-BAU					
WSES-NZE	2050	100		100	[24]
CE4EUI	2025	5		20	
	2030	15		35	
	2035	30		50	
	2040	55		65	
	2045	80		80	
	2050	100		100	
Maximum Capacity in 2050 (MW)					
Scenario	Solar	Wind Offshore	Wind Onshore	Wave Energy	Bio + Geothermal
WSES-BAU	15	6	0.3	1.7	12
WSES-NZE					
CE4EUI					

based on its specific projection parameters and trends.

The **Baseline scenario** is the reference scenario against which the other results are compared. As explained before, it is developed assuming that the energy system undergoes the goals of the renewable transition [1]. In this scenario, none of the changes planned for improving the island water system, such as the improvement of the water distribution grid [85] and wastewater reuse [74], are present: The desalination plant can install new capacities to meet the growing water demand caused by increased tourism and water network losses. The losses follow the typical ageing trend of the hydraulic network of the Sicily region, which is among the less efficient water pipelines in Italy [64]. Such a trend foresees a 10 % deterioration increase by 2050 [82]. To evaluate the performance of the integrated approach, the **Baseline** scenario is compared with its analogue scenario implemented in the energy-only model (**WSES-NZE**).

In the **Losses Decreasing scenario (LD)**, the only variation compared to the **Baseline scenario** is the improvement of the water distribution system in line with the national plans, aiming to reduce the losses by 20 % in 2050 [85]. Italy, in general and especially its southern parts, suffer from aged and leaky water distribution infrastructure [86]. An issue which leads to higher consumption of both energy and water resources. Dealing with a real and actual problem which impacts both systems and is among the national plans, it has been adopted as a scenario. The variations in the state of the hydraulic system are applied to the model through the efficiency increase of the representative technology.

The last scenario, **Reclaimed Water Use (RWU)**, focuses on the variations in the water supply and electricity consumption by introducing a small share of water reuse. Currently, in Italy, reclaimed water reuse is not widespread. Of the total 23 % available reclaimed water, only 4 % is reused, and this is restricted to the agriculture sector [87]. In almost all cases, treated wastewater is discharged into the water bodies. The quality requirements of the treated water are regulated by law [88], but based on the criticality of the receiving body, regional authorities can impose different thresholds. The European Directive EU 2020/741 [74], which establishes the minimum requirements and monitoring criteria of reclaimed water, paves the way for the reuse in industry and agriculture, promoting a more circular approach.

The existing WWTP of the island, as explained, is not in compliance with the EU regulation. So, to reduce the environmental and health impact, the existing primary plant must be replaced with a secondary plant. The water reuse scenario takes advantage of these necessities by analysing how a potential water reuse will affect the energy and water systems of the island. However, construction of such a plant goes far

beyond mere energy and water convenience and addresses human health and nature safeguard. To evaluate how water reuse may impact the island, a scenario with 2 % reclaimed water reuse in WC flush tanks of residential, service, bars, and hotels, and 5 % reutilization in the agriculture sector has been examined. The scenario aims to investigate the effect of water reuse introduction on the activity of the desalination plant and its electricity consumption.

The characteristics and constraints of all scenarios introduced before are summarized in Table 11.

3. Results

This section analyses the results and highlights the key findings of the scenarios explored. It compares the outputs of the integrated model with those of the energy-only system. In Section 3.1, a validation of the TEMOA-Pantelleria energy model has been reported, followed by Section 3.2, including a comparison of the model results against the Energy Transition Plan [33] of the island. In Section 3.3, the focus is on the integrated model's ability to accurately describe and model the evolution of energy and water supplies. The effects of improving water distribution network efficiency and introducing water reuse on the island's energy and water systems are examined in Sections 3.4 and 3.5, respectively.

3.1. Model validation

This section presents the results of the energy-only model (WSES) for the Business-As-Usual (WSES-BAU) and Net Zero Emissions (WSES-NZE) scenarios. Although the main focus of this study is the integrated model analysis, the energy model was first validated to ensure its robustness. Because of the lack of time series data, a point-by-point validation of the model was performed, comparing its outcomes with the available data. The model has 29 GWh energy consumption in 2018, very close to the 31 GWh reported by other studies [33,89]. In particular, the energy consumption due to desalination is very well reproduced, which turns out to be exactly 3.7 GWh, as reported in [89].

The Plausibility of the future results in the WSES-NZE scenario is supported by those reported in the CE4EUI [32]. A comparison of the model's energy mix with that proposed by the island's Energy Transition Agenda [84] and CE4EUI [32] is presented in Fig. 8. As can be seen, the energy mix in WSES-NZE differs only slightly from CE4EUI's projections, likely due to differences in constraints. Specifically, TEMOA prioritizes wind and solar energy while reducing reliance on biomass and geothermal and excluding wave energy due to higher costs. This suggests that additional incentives may be necessary to make geothermal, biomass, and wave technologies competitive with solar and wind.

Regarding the energy demand, the increase in electricity consumption observed in the WSES-NZE scenario is also confirmed by CE4EUI: the WSES-NZE scenario results in an electricity demand of approximately 42 (GWh), aligning closely with the 45 (GWh) predicted by the transition agenda CE4EUI [32].

3.2. Energy-only scenarios: comparison of scenarios

Focusing on the comparison between the WSES-BAU and WSES-

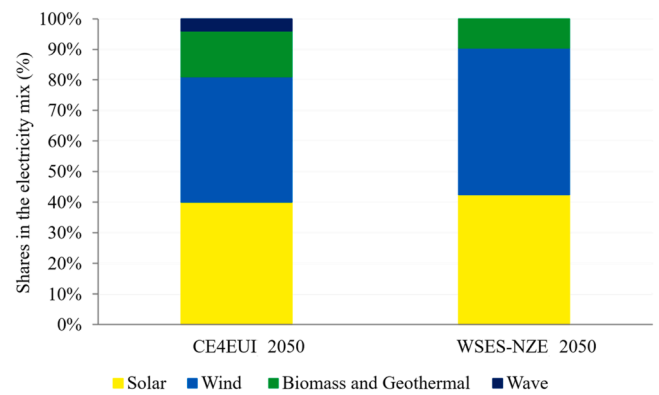

Fig. 8. Comparison of the electricity mix³ in 2050 among the Pantelleria Energy Transition Agenda, CE4UI and WSES-NZE.

NZE scenarios, they differ significantly in both energy mix and total electricity production. In the WSES-BAU scenario, the electricity mix remains unchanged and is the same as the current situation, without any renewable energy technologies. As a result, electricity continues to be supplied exclusively by diesel power plants (Fig. 9, a). In contrast, in the WSES-NZE scenario, the energy mix shifts toward renewable sources (Fig. 9, b).

In terms of power generation, the WSES-BAU scenario maintains relatively stable power generation levels as no electrification measures for the transportation, commercial and residential sectors are planned. Energy demand follows a similar trend to the current one, with increases driven only by external factors such as growth in tourism [77]. In contrast, the WSES-NZE scenario sees an evident increase in electricity generation, driven by growing demand from electrification. This statement is confirmed by the fact that the total difference in energy consumption between the two scenarios is almost equal to the sum of the electrification differences across all sectors, as visible in Table 12. It is important to note that 2025 is the starting year of the scenarios' implementation.

3.3. Energy-only model with integrated modules

Comparison of the integrated (Baseline and LD) with energy-only (WSES-NZE) models (Fig. 9) shows different outcomes in terms of produced electricity and technology mix. The differences between WSES-NZE (Fig. 9b) and the two scenarios implemented in the integrated modules (Fig. 9c and 9d) emerge from 2025, which is the first milestone year after implementation of the energy transition. The higher electricity demand in 2050 in the integrated modules arises from the capability of these configurations to follow the water demand increases. This increase, in turn, impacts the energy consumption of the desalination plant (see also Fig. 11). Concerning qualitative dissimilarities, while in WSES-NZE, electricity production relies mostly on diesel and the use of renewable energies is postponed to 2030, in Baseline and LD, the model anticipates the integration of renewables through the centralized and distributed solar installations. Moreover, the Baseline and LD scenarios implemented in the integrated system (Fig. 9c and 9d) manifest the changes in the water system not only in terms of needed megawatt-hours (MWh) but also in the energy sources mix to meet them.

Table 11

Features of the scenarios implemented in the TEMOA-Pantelleria.

Scenario	Desalination plant increasing capacity	Water pipeline improvement	Reclaimed water reuse	Model	Energy transition
WSES-BAU	Yes	No	No	Energy	No
WSES-NZE	Yes	No	No	Energy	Yes
Baseline	Yes	No	No	Integrated	Yes
LD	Yes	Yes	No	Integrated	Yes
RWU	Yes	No	Yes	Integrated	Yes

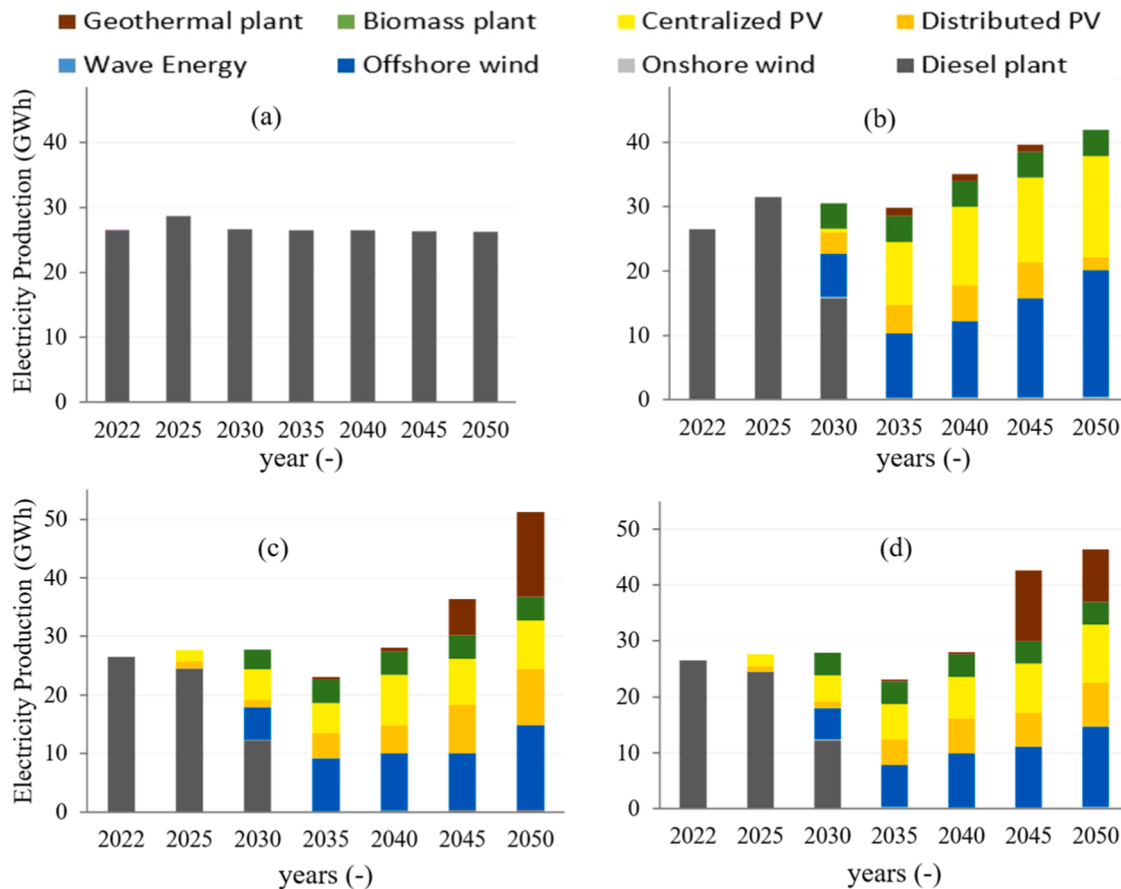

Fig. 9. Electricity mix⁴ of: (a) *WSES-BAU*, (b) *WSES-NZE* model, and Integrated model: (b) *Baseline* and (c) *LD* scenarios.

Table 12

Difference between sectoral (transportation, residential, and commercial) and total electricity consumption across WSES scenarios.

	2025	2030	2035	2040	2045	2050
Transport (GWh)						
WSES-BAU	0.0	0.0	0.0	0.0	0.0	0.0
WSES-NZE	0.0	0.0	0.1	4.2	7.7	10.3
Residential (GWh)						
WSES-BAU	6.4	6.2	6.2	6.2	6.2	6.1
WSES-NZE	9.5	9.0	8.9	8.9	8.9	8.9
Commercial (GWh)						
WSES-BAU	5.4	4.6	4.5	4.5	4.5	4.5
WSES-NZE	5.4	4.6	4.5	4.8	5.4	6.0
Total Electricity (GWh)						
WSES-BAU	28.7	26.6	26.5	26.4	26.3	26.3
WSES-NZE	31.7	30.5	29.8	35.1	39.1	41.9

Fig. 10 shows the water supplied in *WSES-NZE* and *Baseline*. The purple line represents the supplied water in *WSES-NZE*, which consists only from the desalination plant. The colored (blue and yellow) areas show the supplied water in *Baseline*, including two imported and desalinated water supply methods.

As evident, the two scenarios substantially differ, both quantitatively and qualitatively. The quantitative differences in the outputs are due to the more accurate projection of the water supply side in *Baseline*, by considering import and desalination. As mentioned earlier, in *WSES-NZE*, the water supply can be modeled only through desalination, as imports do not directly consume electricity.

In addition, the *Baseline* scenario enables the subdivision of the water demand into different sub-sectors and the attribution of specific drivers to each of them, fixed and seasonal populations, while in *WSES-*

NZE (purple line), the driving factor of the water demand projection refers solely to the seasonal population. Consequently, different demand projections lead to different water supply trends: *WSES-NZE* exhibits a sudden increase influenced by the seasonal population growth from 2020 to 2025 and remains constant after that. Such an increase forces the energy model to raise the installed capacity of desalination plants, which is the only technology that covers the demand. In *Baseline*, water demand projected through two drivers undergoes a gradual increase both in terms of supplied water and installed capacities.

Besides being able to show the effects of a diversified supply side, another important outcome of the integrated modeling missed by *WSES-NZE* is the demonstration of the convenience of the in-situ water supply (yellow area). As time goes by and the installed capacity of the desalination plants gets enough to satisfy the water demand internally, the imported water decreases, till disappearing by 2050 (the blue area). This is due to the economic convenience of supplying water through desalination plants. Such critical shifts in resource supply methods underline the importance of considering integrated trends in policymaking. Policymakers must take into account the long-term benefits of fostering local water production, as it helps to realize more resilient plans with reduced dependency on external sources, aligned with the Sustainable Development Goals [90,91]. Moreover, *Baseline* shows to be more precise than *WSES-NZE* in modeling the electricity consumed by the desalination plant because of capturing the water supply together with energy consumption (see Fig. 11). In 2025 (left-hand side bars), the higher water produced by the desalination plant in *WSES-NZE* compared to *Baseline* leads to a relatively higher electricity consumption in *WSES-NZE*. The same effect also manifests in Fig. 10 through the difference between the sum of the colored areas and the purple line. The consumed electricity changes in 2050 (right-hand side bars), as the

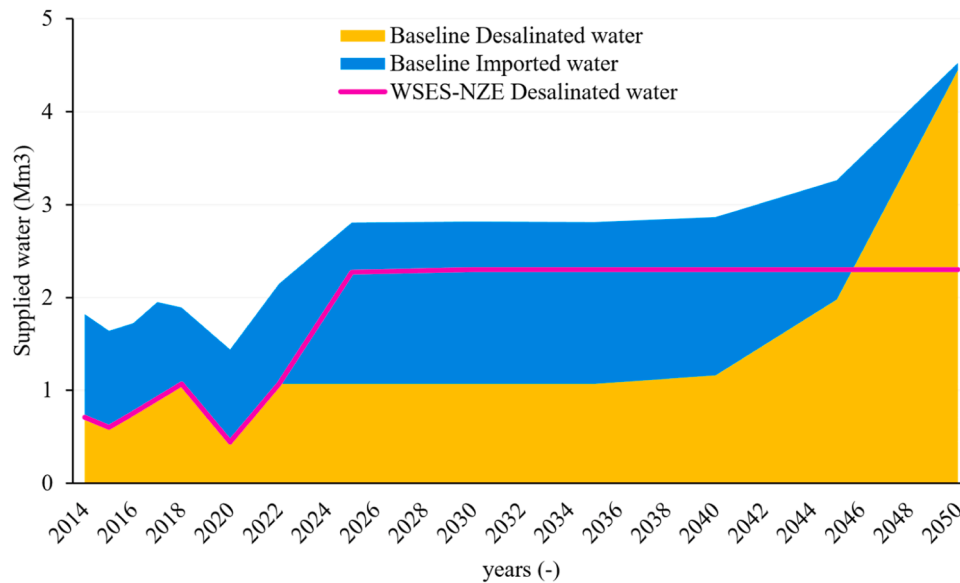

Fig. 10. Comparison of the water supply side modelled in energy (continuous line, *WSES-NZE*) and integrated systems (colored areas, *Baseline*).

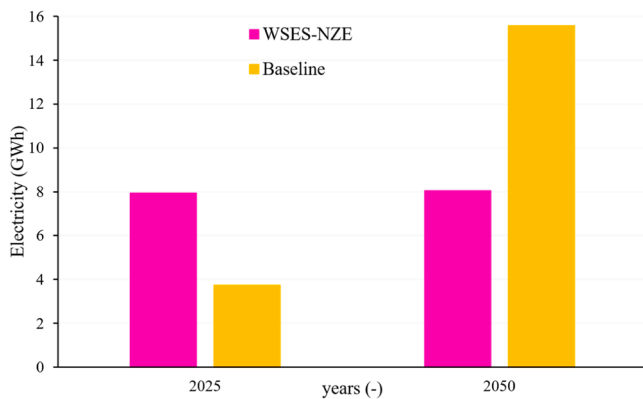

Fig. 11. Comparison of the consumed electricity by desalination plants in *Baseline* (in yellow) and *WSES-NZE* (in pink) in two representative years.

Baseline scenario relies entirely on desalination, resulting in significantly higher electricity consumption compared to the previous case. As discussed above, the steady state in the supply technology in *WSES-NZE* (purple line in Fig. 10) leads to unchanged consumed electricity in the two example years (Fig. 11).

These findings align with previous studies, highlight the strong link between desalination and rising energy demand. In Saudi Arabia, for instance, electricity consumption for water desalination tripled between 2005 and 2020, reaching approximately 6 % of the country’s total electricity demand [92]. Furthermore, the increasing dependence on fossil fuels for desalination raises concerns about long-term sustainability, both in terms of energy security and environmental impact.

In island contexts, the impact of desalination on electricity demand is even more pronounced due to limited local water resources and heavy reliance on energy imports. In the Canary Islands, for example, the growing need for fresh water, driven by increased tourism and population, has led to a significant increase in electricity consumption by desalination plants [93,94]. This trend underscores the critical role of the energy-water nexus in island environments, where water supply constraints amplify dependence on energy-intensive solutions. The integration of renewable energy sources has been proposed as a key strategy to reduce the carbon footprint of desalination while improving the long-term economic viability of water production in these settings.

3.4. Water distribution system assessment

Once the potential and benefits of implementing the integrated modeling have been shown, the focus shifts to the results related to the water supply network and its substantial impact on the energy system. Water loss due to ageing pipelines is a major issue for Italian water management, particularly in the southern regions. At the country level, more than 40 % of the supplied water is lost in the water-distribution network, and Sicily is among the regions with the highest water losses [95].

The analysis considers the model response to two distinct situations, both addressing the same final demand but accounting for different physical conditions of the water distribution system. As expected, and confirmed by the outputs, the condition of the hydraulic system significantly influences the water supply and its corresponding energy demand.

Two scenarios, *LD* and *Baseline*, are visible in Fig. 12, respectively shown with dashed and solid lines. Modeled in the integrated module, the supply methods include desalination and import. In both scenarios and to meet the same water demand in both scenarios the on-site water supply (desalination) substitutes for water import. As expected, the supplied water in *LD* is less than *Baseline*, in which ageing of the system leads to a higher leakage. Subsequently, a higher water input is needed to satisfy the demand.

The difference in the substitution trends (manifesting in different slopes) in the two scenarios is a result of the maximum available

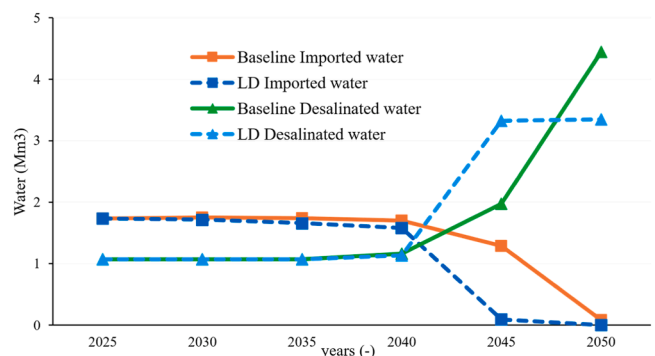

Fig. 12. Supplied water in *LD* and *Baseline* scenarios.

capacities. As the pipelines deteriorate and more water is leaked, the desalination plants are not able to cover the water demand even if the plants are at maximum activity. Thus, in **Baseline**, the reduction in imports occurs at a slower rate than in **LD** (slope difference between square markers and triangle markers lines in Fig. 12). In summary, despite having the same desalination capacity constraints, in **Baseline**, the import stops only by 2050, while in the **LD**, it happens by 2045. The difference in water demands by 2050 in the two scenarios is around 1 million cubic meters (the difference between dashed and solid triangle marker lines).

It is worth noting that in the early years, the small difference between the losses in the two scenarios (lines with the same markers in Fig. 12) results in similar tendencies. However, as time progresses, in **Baseline** the losses increase, while they decrease in the **LD** scenario and resulting in pronounced divergences between the two trends. Note also that the difference in the supplied water brings in different activities of the desalination plant, which leads in turn to different energy consumptions, as shown in Fig. 13. As visible in the figure, the electricity demand of the desalination plant in the **LD** scenario in 2050 (12 GWh), compared to more than 15 (GWh) in **Baseline** (difference between the green and yellow bars) shows the quantitative effect of the pipeline renewal on energy uses (more than 5 GWh less). Another outcome relates to the same level of electricity consumption in **LD** in 2045 and 2050 (green bars) despite the evolution of the populations (i.e., the driver of the demands). This happens because the imported water in 2045 is still present and constitutes a more convenient resource with respect to the desalinated one.

3.5. Introduction of reclaimed water reuse

The new wastewater treatment plant is assumed to start working in 2025. Thanks to its nitrogen and phosphorus removal units, a potential reuse of reclaimed water can be implemented.

As expected, due to the demographic, agricultural and industrial structure of the island, the effect of reclaimed water reuse is very restricted: The island has no major industrial activities, and the agricultural cultivations (vineyards and capers) are mostly rainfed and do not demand irrigation. Thus, the assumed share of reclaimed water reuse in the agriculture sector cannot increase much. Consequently, the water and electricity demand reductions due to water reuse are limited. As it was mentioned in the introduction section, the effect of the treatment level is implemented through the higher costs of the installed units and the maintenance (variable costs in the model).

In Table 13, the produced water in the desalination plant in **Baseline** and **RWU** is compared. In the initial years, the reduction of treated water in desalination due to water reuse is very restricted. This is because the imported water still plays an important role in the water supply of the island. As the water import decreases, the share of reused reclaimed water in the reduction of the desalination activity becomes more evident

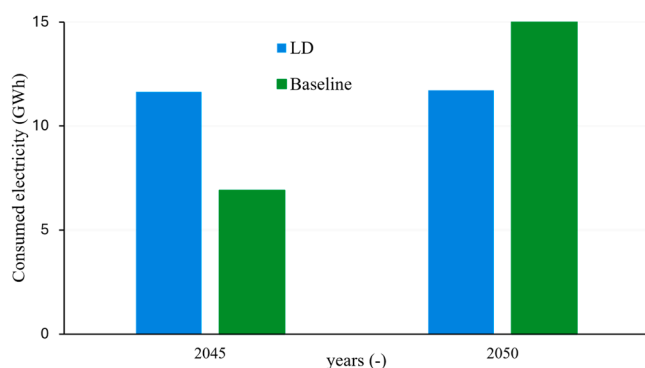

Fig. 13. Desalination plant electricity consumption in **Baseline** and **LD** scenarios in two milestone years.

Table 13

Activity of the desalination in Baseline and RWU Scenarios, and desalinated water and electricity use reduction due to water reuse.

Scenario	Desalination activity (Mm ³)					
	2025	2030	2035	2040	2045	2050
Baseline	1.07 × 10 ⁶	1.07 × 10 ⁶	1.07 × 10 ⁶	1.16 × 10 ⁶	1.98 × 10 ⁶	4.45 × 10 ⁶
RWU	1.07 × 10 ⁶	1.07 × 10 ⁶	1.07 × 10 ⁶	1.12 × 10 ⁶	1.65 × 10 ⁶	3.45 × 10 ⁶
Variation of produced water and consumed electricity in desalination plant due to water reuse						
Desalinated water reduction (Mm ³)	0	0	0	4.3 × 10 ⁴	3.2 × 10 ⁵	1.0 × 10 ⁶
Electricity consumption reduction (%) in RWU with respect to Baseline	0 %	0 %	0 %	4 %	13 %	16 %

until reaching the maximum in 2050 (3.45 million cubic meters, 1 (Mm³) less with respect to the same situation in **Baseline**). This effect is also visible in the reduction of the electricity consumption of the desalination plant in two scenarios (see the last line of Table 13), which in 2050 reaches its highest value. It shows a 16 % reduction in consumption, reaching 13.1 (GWh) with respect to 15.56 (GWh) of the **Baseline** scenario (see Fig. 13, yellow bar in 2050) when the water is totally supplied by the desalination plants.

The effect of water reuse depends very much on the final water demands of the studied case. This outcome could also be of interest for the water and energy management stakeholders since, for Pantelleria, the reclaimed water reuse could become significant in practices such as hydrogen production from water electrolysis technologies. Such usage will avoid exerting pressure on the drinking water resources and entering competition with human water requirements.

4. Discussion and conclusions

This work addresses the lack of detailed and fully integrated energy-water nexus analyses by embedding water and energy systems within the open-source energy system optimization model TEMOA, for the case of Pantelleria Island. The island’s vulnerability to climate change and water scarcity, combined with its potential role in the European energy transition, make it a particularly suitable case study. Its relatively simple energy and water systems also make it a manageable pilot site for implementing an integrated water-energy nexus model. The developed model was validated against 2018 electricity consumption data, with a strong alignment (29 GWh), and showed perfect agreement for the electricity used in the desalination plant (3.7 GWh).

Compared to an energy-only model, the integrated approach provided more accurate water demand projections and revealed a higher energy demand, along with a more diversified renewable energy mix, in response to increased water needs. On the water supply side, the integrated model identified a complete shift toward local water production through desalination, optimizing the trade-off between in-situ production and imports - something the energy-only model failed to capture. It turned out that desalination, coming with an associated energy demand, has a critical role in securing freshwater supply. This is especially relevant for islands with a strong tourism sector, where high water demand fluctuations further complicate planning. The nexus approach allowed identifying a different energy transition pathway than that proposed by CE4EU1, and underscoring the impact of water-energy interactions on technology choices. These findings highlighted the value of integrated modeling for more robust planning.

The study also showed how mitigating ageing water infrastructure can enhance efficiency: despite full reliance on desalination and rising water demand, infrastructure improvements resulted in a reduction of 1 (Mm³) of water use by 2045, without increasing energy consumption.

For isolated systems like Pantelleria, this points to significant opportunities for joint water-energy efficiency gains. In terms of wastewater treatment, while upgrading from a primary to a secondary treatment plant increased energy demand, regulatory and environmental requirements make this transition necessary. The model also examined the limited but noteworthy contribution of water reuse, suggesting that its integration with electrolysis for green hydrogen production could open new sustainability pathways. Leveraging the island's diverse renewable resources (geothermal, wave, wind, and solar), such synergies could support Pantelleria's role in national and European green hydrogen strategies. The integrated modeling approach used in this study provides practical and strategic insights for decision-makers. By accounting for interdependencies between water and energy systems, it supports more comprehensive and realistic planning processes, especially relevant in isolated and resource-constrained contexts like small islands. For Pantelleria, the findings suggest that future energy transition plans must consider the growing impact of water demand on energy consumption, particularly in light of climate change and tourism-driven seasonality. Policymakers can draw from this study guidelines for infrastructure investments and expenditures optimization, achieving greater returns in terms of sustainability and system resilience.

Despite its strengths, this study also has limitations. One key constraint is the lack of localized investment and forecast data for Pantelleria, which limits the precision of some scenario assumptions. The reuse scenario, in particular, depends on the availability of adequate infrastructure, and its capital and operational costs have not yet been fully represented in the model. Incorporating these costs would improve the realism of future reuse assessments. Another limitation lies in the modeling of precipitation. Models like TEMOA are not inherently designed to handle climate variables. In this study, precipitation was introduced via historical rainfall time series, which, while common practice, lacks forward-looking climate projections that could significantly affect water availability. Moreover, the current model does not account for elements such as the sludge line in wastewater treatment, which could be relevant for evaluating biogas recovery and the energy neutrality potential of treatment plants, particularly in view of new European directives. The theoretical foundation of the study can be improved and strengthened by adopting it within broader contexts such as regional or national level models. Such a practice helps to evaluate the method's validation in an energy transition and nexus context and align the system interdependencies with techno-economic requirements. Finally, further development could explore the integration of green hydrogen production with water reuse, assessing its impact on the island's energy mix and long-term transition trajectory. This would allow a better understanding of how Pantelleria could contribute to and benefit from emerging European hydrogen networks.

Glossary

Abbreviation	Definition
BOD	Biochemical Oxygen Demand
BAU	Business As Usual
CE4EUI	Clean Energy for EU Islands
EDR	Electrodialysis Reversal
ESOM	Energy System Optimization Model
EV	Electric Vehicle
GRAPS	Generalized Multi-Reservoir Analyses using Probabilistic Streamflow Forecasts
GIS	Geographic Information Systems
ISTAT	Italian National Statistics Institute (Istituto Nazionale di Statistica)
LD	Losses Decreasing
LEAP	Low Emissions Analysis Platform
LPG	Liquefied Petroleum Gas
MC	Mechanical Steam Compression
NZE	Net Zero Emission
OSMOSYS	Open-Source Energy Modeling System
P.E.	People Equivalent
P.L.	Physical Losses

(continued on next column)

(continued)

RES	Reference Energy System
RO	Reverse Osmosis
RWS	Reference Water System
RWU	Reclaimed Water Use
SDG	Sustainable Development Goal
TEMOA	Tool for Energy Models Optimization and Analysis
TIAM	TIMES Integrated Assessment Model
TIMES	The Integrated MARKAL-EFOM System
WEAP	Water Evaluation and Planning System
WRIMS	Water Resource Integrated Modeling System
WSES-BAU	Water Supply modeled in Energy only System – Business As Usual
WSES-NZE	Water Supply modeled in Energy only System – Net Zero Emission
WWTP	Wastewater Treatment Plant

Funding

The work by Farzaneh Amir Kavei and Matteo Nicoli was funded by the European Union - NextGenerationEU, in the framework of the GRINS - Growing Resilient, INclusive and Sustainable project (GRINS PE00000018 – CUP D13C22002160001). The views and opinions expressed are solely those of the authors and do not necessarily reflect those of the European Union, nor can the European Union be held responsible for them.

CRediT authorship contribution statement

Farzaneh Amir Kavei: Writing – review & editing, Writing – original draft, Validation, Software, Methodology, Investigation, Formal analysis, Data curation, Conceptualization. **Maria Elena Alfano:** Writing – review & editing, Writing – original draft, Validation, Software, Methodology, Investigation, Formal analysis, Data curation, Conceptualization. **Matteo Nicoli:** Writing – review & editing, Validation, Software, Conceptualization. **Francesco Quattraro:** Supervision. **Laura Savoldi:** Writing – review & editing, Supervision, Methodology, Funding acquisition, Conceptualization.

Declaration of competing interest

The authors declare that they have no known competing financial interests or personal relationships that could have appeared to influence the work reported in this paper.

Acknowledgements

The authors thank the MAHTEP Group members for their precious collaboration. We would like to extend our special thanks to Prof. Rufino for the very constructive discussions.

Data availability

Data will be made available on request.

References

- [1] W.S. DeAmorim, et al., The nexus between water, energy, and food in the context of the global risks: an analysis of the interactions between food, water, and energy security, *Env. Impact Assess Rev* 72 (2018) 1–11, <https://doi.org/10.1016/j.eiar.2018.05.002>. Sep.
- [2] A. Boretti, L. Rosa, Reassessing the projections of the World Water Development Report, *NPJ. Clean. Water.* 2 (1) (2019) 1–6, <https://doi.org/10.1038/s41545-019-0039-9>. Jul.
- [3] United Nation, “Water, Food and Energy.” Accessed: Sep. 06, 2023. [Online]. Available: <https://www.unwater.org/water-facts/water-food-and-energy>.
- [4] Stockholm Environment Institute's U.S. Center., “WEAP: Water Evaluation And Planning System.” Accessed: Feb. 20, 2024. [Online]. Available: <https://www.weap21.org/index.asp?NewLang=EN>.
- [5] California Department of Water Resources, “WRIMS: Water Resource Integrated Modelling System.” Accessed: Sep. 01, 2023. [Online]. Available: <https://water.ca>.

- gov/Library/Modeling-and-Analysis/Modeling-Platforms/Water-Resource-Integrated-Modeling-System.
- [6] International Energy Agency, "WEO - Special Report: Water-Energy Nexus - Analysis - IEA," 2016. Accessed: Sep. 01, 2023. [Online]. Available: <https://www.iea.org/reports/water-energy-nexus>.
- [7] N. Carter, "Energy-Water Nexus: The Water Sector's Energy Use Claudia Copeland Specialist in Resources and Environmental Policy," 2017, Accessed: Sep. 01, 2023. [Online]. Available: <https://sgp.fas.org/crs/misc/R43200.pdf>.
- [8] UN Water, "Water and Climate Change." Accessed: Sep. 17, 2024. [Online]. Available: <https://www.unwater.org/water-facts/water-and-climate-change>.
- [9] S. Barbetta, et al., Assessment of flooding impact on water supply systems: a comprehensive approach based on DSS, *Water Resour. Manag.* 36 (14) (2022) 5443–5459, <https://doi.org/10.1007/s11269-022-03306-X/TABLES/5>. Nov.
- [10] K.L. See, N. Nayan, Z.A. Rahaman, Flood disaster water supply: a review of issues and challenges in Malaysia, *Int. J. Acad. Res. Bus. Soc. Sci.* 7 (10) (2017), <https://doi.org/10.6007/IJARBS/7-10/3406>. Nov.
- [11] D. Benson, A.K. Gain, J.J. Rouillard, Water governance in a comparative perspective: from IWRM to a 'Nexus' Approach? *Water Altern.* 8 (1) (2015) 756–773. Accessed: Feb. 19, 2024. [Online]. Available: www.water-alternatives.org.
- [12] F. Brouwer, et al., Energy modelling and the Nexus concept, *Energy Strategy Rev.* 19 (2018) 1–6, <https://doi.org/10.1016/j.esr.2017.10.005>. Jan.
- [13] Integrating the WEAP and LEAP systems to support planning and analysis at the water-energy nexus Geographical focus: Global, with first application in California, USA, Somerville, 2012. Accessed: Sep. 01, 2023. [Online]. Available: www.weap21.org.
- [14] N. Agrawal, M. Ahiduzzaman, A. Kumar, The development of an integrated model for the assessment of water and GHG footprints for the power generation sector, *Appl. Energy* 216 (2018) 558–575, <https://doi.org/10.1016/j.apenergy.2018.02.116>. Apr.
- [15] T.A. DeNooyer, J.M. Peschel, Z. Zhang, A.S. Stillwell, Integrating water resources and power generation: the energy-water nexus in Illinois, *Appl. Energy* 162 (2016) 363–371, <https://doi.org/10.1016/j.apenergy.2015.10.071>. Jan.
- [16] W. Li, Y. Liang, L. Liu, Q. He, J. Huang, Z. Yin, Spatio-temporal impacts of land use change on water-energy-food nexus carbon emissions in China, 2011–2020, *Env. Impact Assess Rev* 105 (2024) 107436, <https://doi.org/10.1016/j.eiar.2024.107436>. Mar.
- [17] T. Shao, T. Peng, L. Zhu, Y. Lu, L. Wang, X. Pan, China's transportation decarbonization in the context of carbon neutrality: a segment-mode analysis using integrated modelling, *Env. Impact Assess Rev* 105 (2024) 107392, <https://doi.org/10.1016/j.eiar.2023.107392>. Mar.
- [18] T. Huo, Q. Du, T. Yuan, W. Cai, W. Zhang, Has the provincial-level residential building sector reached the carbon peak? An integrated assessment model, *Env. Impact Assess Rev* 105 (2024) 107374, <https://doi.org/10.1016/j.eiar.2023.107374>. Mar.
- [19] N. Agrawal, M. Ahiduzzaman, A. Kumar, The development of an integrated model for the assessment of water and GHG footprints for the power generation sector economic incentives, *Renew. Sustain. Energy Rev.* 152 (2021), <https://doi.org/10.1016/j.rser.2021.111663>. Dec.
- [20] A. Dubreuil, E. Assoumou, S. Bouckaert, S. Seloese, N. Maïzi, Water modeling in an energy optimization framework – the water-scarce middle east context, *Appl. Energy* 101 (2013) 268–279, <https://doi.org/10.1016/j.apenergy.2012.06.032>. Jan.
- [21] R. Loulou, G. Goldstein, K. Noble, Energy Technology Systems Analysis Programme Documentation for the MARKAL Family of Models, 2004. Accessed: Sep. 01, 2023. [Online]. Available: <http://www.etsap.org/tools.htm>.
- [22] L. Ford, A. de Queiroz, J. DeCarolis, A. Sankarasubramanian, Co-optimization of reservoir and Power systems (COREGS) for seasonal planning and operation, *Energy Rep.* 8 (2022) 8061–8078, <https://doi.org/10.1016/j.egyr.2022.06.017>. Nov.
- [23] D. Groppi, S. Kumar Pinayur Kannan, F. Gardumi, D. Astiaso Garcia, Optimal planning of energy and water systems of a small island with a hourly OseMOSYS model, *Energy Convers. Manage* 276 (2023) 116541, <https://doi.org/10.1016/j.enconman.2022.116541>. Jan.
- [24] D. Mosso, L. Rajteri, L. Savoldi, Integration of land use potential in energy system optimization models at regional scale: the Pantelleria Island case study, *Sustainability.* 16 (4) (2024) 1–34. Accessed: Jul. 01, 2024. [Online]. Available: <https://ideas.repec.org/a/gam/jsusta/v16y2024i4p1644-d1340034.html>.
- [25] A. Polido, E. João, T.B. Ramos, Strategic Environmental Assessment practices in European small islands: insights from Azores and Orkney islands, *Env. Impact Assess. Rev.* 57 (2016) 18–30, <https://doi.org/10.1016/j.eiar.2015.11.003>. Feb.
- [26] E.P. Ramos, et al., Climate, land, energy and Water systems interactions – from key concepts to model implementation with OseMOSYS, *Env. Sci Policy* 136 (2022) 696–716, <https://doi.org/10.1016/j.envsci.2022.07.007>. Oct.
- [27] Y. Xuan, L. Ford, K. Mahinthakumar, A. De Souza Filho, U. Lall, A. Sankarasubramanian, GRAPS: generalized Multi-Reservoir analyses using probabilistic streamflow forecasts, *Environ. Model. Softw.* 133 (2020), <https://doi.org/10.1016/j.envsoft.2020.104802>. Nov.
- [28] M. Nicoli, V.A.D. Faria, A.R. de Queiroz, L. Savoldi, Modeling energy storage in long-term capacity expansion energy planning: an analysis of the Italian system, *J. Energy Storage* 101 (2024) 113814, <https://doi.org/10.1016/j.est.2024.113814>. Nov.
- [29] A. Vai, G. Colucci, M. Nicoli, L. Savoldi, May the availability of critical raw materials affect the security of energy systems? An analysis for risk-aware energy planning with TEMOA-Italy, *Mater. Today Energy* 48 (2025) 101805, <https://doi.org/10.1016/j.mtener.2025.101805>. Mar.
- [30] F. Amir Kavei, M. Nicoli, F. Quattraro, L. Savoldi, Enhancing energy transition with open-source regional energy system optimization models: TEMOA-Piedmont, *Energy Convers. Manage* 327 (2025) 119536, <https://doi.org/10.1016/j.enconman.2025.119536>. Mar.
- [31] Il Post, "La siccità ha diminuito del 20 per cento la produzione di uva da vino in Sicilia -," *Il Post*, Nov. 2024, Accessed: Jan. 29, 2025. [Online]. Available: <https://www.ilpost.it/2024/11/07/siccita-sicilia-diminuzione-produzione-vino/>.
- [32] Clean Energy for EU Islands, From Vision to Action: How to Tackle Transition on EU Islands? Methodological Handbook, Publications Office of the European Union, 2022, <https://doi.org/10.2833/822820>.
- [33] Pantelleria Zero, Agenda per la Transizione Energetica, 2020. Accessed: Jun. 18, 2024. [Online]. Available: https://clean-energy-islands.ec.europa.eu/sites/default/files/inline-files/PR111040_CETA_Pantelleria_102020.pdf.
- [34] X. Chen, M. Chen, Energy, environment and industry: instrumental approaches for environmental regulation on energy efficiency, *Env. Impact Assess. Rev.* 105 (2024) 107439, <https://doi.org/10.1016/j.eiar.2024.107439>. Mar.
- [35] J. Xie, Z. Xia, X. Tian, Y. Liu, Nexus and synergy between the low-carbon economy and circular economy: a systematic and critical review, *Env. Impact Assess. Rev.* 100 (2023) 107077, <https://doi.org/10.1016/j.eiar.2023.107077>. May.
- [36] T. Niet, A. Shivakumar, F. Gardumi, W. Usher, E. Williams, M. Howells, Developing a community of practice around an open source energy modelling tool, *Energy Strategy Rev.* 35 (2021), <https://doi.org/10.1016/j.esr.2021.100650>. May.
- [37] K. Hunter, S. Sreepathi, J.F. DeCarolis, Modeling for insight using tools for energy model optimization and analysis (Temoa), *Energy Econ.* 40 (2013) 339–349, <https://doi.org/10.1016/j.eneco.2013.07.014>. Nov.
- [38] M. Nicoli, F. Graceva, D. Lerede, L. Savoldi, Can we rely on open-source energy system optimization models? The TEMOA-Italy case study, *Energies* 15 (18) (2022) 6505, <https://doi.org/10.3390/en15186505>. Sep.
- [39] N. Patankar, H.G. Fell, A. Rodrigo de Queiroz, J. Curtis, J.F. DeCarolis, Improving the representation of energy efficiency in an energy system optimization model, *Appl. Energy* 306 (2022) 118083, <https://doi.org/10.1016/j.apenergy.2021.118083>. Jan.
- [40] J.F. DeCarolis, K. Hunter, How much should we value uncertainty in energy system planning?. International Energy Workshop, 2013. Accessed: Sep. 04, 2023. [Online]. Available: https://temoacloud.com/wp-content/uploads/2019/12/DeCarolis_IEW2013_paper.pdf.
- [41] V.A.D. Faria, A. Rodrigo de Queiroz, J.F. DeCarolis, Scenario generation and risk-averse stochastic portfolio optimization applied to offshore renewable energy technologies, *Energy* 270 (2023) 126946, <https://doi.org/10.1016/j.energy.2023.126946>. May.
- [42] G. Colucci, D. Lerede, M. Nicoli, L. Savoldi, A dynamic accounting method for CO2 emissions to assess the penetration of low-carbon fuels: application to the TEMOA-Italy energy system optimization model, *Appl. Energy* 352 (121951) (2023), <https://doi.org/10.1016/j.apenergy.2023.121951>. Dec.
- [43] M. Nicoli, G. Colucci, V. Di Cosmo, D. Lerede, L. Savoldi, Evaluating the impact of hurdle rates on the Italian energy transition through TEMOA, *Appl. Energy* 377PC (124633) (2024), <https://doi.org/10.1016/j.apenergy.2024.124633>.
- [44] M. Schäfer, O. Gretzschel, H. Steinmetz, The possible roles of wastewater treatment plants in sector coupling, *Energies* 13 (8) (2020) 2088, <https://doi.org/10.3390/en13082088>. Apr.
- [45] D. Ganora, et al., Opportunities to improve energy use in urban wastewater treatment: a European-scale analysis, *Environ. Res. Lett.* 14 (4) (2019), <https://doi.org/10.1088/1748-9326/AB0B54>. Apr.
- [46] A. Wendland, "Hamburg university of technology E-learning courses - operation costs of wastewater treatment plants," *Hamburg*. Accessed: Sep. 04, 2023. [Online]. Available: https://cgi.tu-harburg.de/~awweb/wbt/emwater/documents/less_on_c2.pdf.
- [47] P.E. Campana, M. Mainardis, A. Moretti, M. Cottes, 100% renewable wastewater treatment plants: techno-economic assessment using a modelling and optimization approach, *Energy Convers. Manage* 239 (2021), <https://doi.org/10.1016/j.enconman.2021.114214>. Jul.
- [48] Y. Pan, A. Hashemizadeh, Circular economy-based assessment framework for enhancing sustainability in renewable energy development with life cycle considerations, *Env. Impact Assess Rev* 103 (2023) 107289, <https://doi.org/10.1016/j.eiar.2023.107289>. Nov.
- [49] Pantelleria Island, "Discover pantelleria." Accessed: Jun. 20, 2024. [Online]. Available: <https://www.pantelleriaisland.it/en/discover-pantelleria.html>.
- [50] M. Mycoo, et al., IPCC Sixth Assessment Report - Small Islands to the Sixth Assessment Report of the Intergovernmental Panel on Climate Change [Chapter 15], 2021, pp. 2043–2121, <https://doi.org/10.1017/9781009325844.017>.
- [51] Interreg MED, "The ecosystemic transition unit (ETU) - interreg MED renewable energy project." Accessed: Sep. 04, 2023. [Online]. Available: <https://etuinitiative.eu/newsletter/the-etu-final-event-policy-recommendations-much-more%E2%9A%A1/>.
- [52] Municipality of Pantelleria, Action Plan for Sustainable Energy, 2015. Accessed: Feb. 19, 2024. [Online]. Available: http://www.smartisland.eu/images/document_i_report/Pantelleria_Paes.pdf.
- [53] M.E. Alfano, "Modeling the Energy and the Water Systems in an open-access Energy System Optimization Model: the Pantelleria case study," *Politecnico di Torino, Torino*, 2022. Accessed: Feb. 07, 2025. [Online]. Available: <https://web.hesis.biblio.polito.it/24982/>.
- [54] G. Taverna, Technical Report, Pantelleria Desalination Plant, 2011. Accessed: Jul. 02, 2024. [Online]. Available: <https://www.comunepantelleria.it/gare/6170604F7E/01%20RELAZIONE%20TECNICA%20GENERALE.pdf>.

- [55] F. Speranza, P. Landi, F. D'Ajello Caracciolo, A. Pignatelli, Paleomagnetic dating of the most recent silicic eruptive activity at Pantelleria (Strait of Sicily), *Bull. Volcanol.* 72 (7) (2010) 847–858, <https://doi.org/10.1007/S00445-010-0368-5>.
- [56] National park of the Pantelleria Island, "Parco Nazionale Isola di Pantelleria." Accessed: Jun. 11, 2024. [Online]. Available: <https://www.parconazionalepantelleria.it/pun-dettaglio.php?id=2439>.
- [57] "Pantelleria Climate, "Weather by month, average temperature (Italy) - weather spark." Accessed: Feb. 20, 2024. [Online]. Available: <https://weatherspark.com/y/68843/Average-Weather-in-Pantelleria-Italy-Year-Round#Figures-Rainfall>.
- [58] L. Civetta, Y. Cornette, G. Crisci, P.Y. Gillot, G. Orsi, C.S. Requejo, Geology, geochronology and chemical evolution of the island of Pantelleria, *Geol. Mag.* 121 (6) (1984) 541–562, <https://doi.org/10.1017/S0016756800030703>.
- [59] M. Civita and M. De Maio, *A new parametric system for the assessment and automatic mapping of ground water vulnerability to contamination*, vol. 72. 2000. Accessed: Feb. 20, 2024. [Online]. Available: <https://iris.polito.it/handle/11583/1393299>.
- [60] S. Gambino, *Intervention and Reduction of Water Losses in the Water Supply and Distribution System on the Island of Pantelleria*, 2016. Accessed: Feb. 20, 2024. [Online]. Available: <http://www.comunepantelleria.it/gare/68550928DE/R.1%20Relazione%20illustrativa%20Consistenza%20della%20rete%20idrica.pdf>.
- [61] UNEP - International Environmental Technology Centre United Nations Environment Programme, *Source Book of Alternative Technologies for Freshwater Augmentation in Latin America and the Caribbean*, 1998 [Online]. Available: <http://www.oas.org/usde/publications/Unit/oea59e/begin.htm>.
- [62] Marco Beccali, José Massimiliano Galletto, Statistical Analysis of Wind Regimes and Productibility of a Wind Farm Site in Sicily. *Forecasting Estimate of Wind Productibility through Neural Networks Analysis*, 2010. Accessed: Feb. 20, 2024. [Online]. Available: https://iris.unipa.it/bitstream/10447/57416/1/ATI2010_03_300%20analisi%20statistica.pdf.
- [63] A. Panagopoulos, Water-energy nexus: desalination technologies and renewable energy sources, *Environ. Sci. Pollut. Res.* 28 (17) (2021) 21009–21022, <https://doi.org/10.1007/s11356-021-13332-8>. May.
- [64] Use and Quality of Water Resources in Italy, ISTAT - The National Statistics Institute, 2019. Accessed: Feb. 20, 2024. [Online]. Available: <https://www.istat.it/it/archivio/234904>.
- [65] Libero Consorzio Comunale di Trapani, "Trend movimento turistico comune di pantelleria (ARRIVI) periodo 2009/2018".
- [66] Circular Tourism Europe, *Managing the Transition to Circular Economy for Tourism Providers A CEnTOUR Handbook*, 2020. Accessed: Sep. 04, 2023. [Online]. Available: <https://circulartourism.eu/wp-content/uploads/2021/02/CIRCULAR-ECONOMY-TRANSITION-FOR-TOURISM-PROVIDERS.pdf>.
- [67] Census of Water for Civil Use, "ISTAT- the national statistics institute." Accessed: Sep. 04, 2023. [Online]. Available: <https://www.istat.it/it/archivio/279363>.
- [68] Sicilian Regional Agency for Environmental Protection - ARPA, *Report - Controls on Wastewater Depuration Plants - ARPA Sicily*, 2019. Accessed: Sep. 04, 2023. [Online]. Available: <https://www.arpasicilia.it/temi-ambientali/acque/controlli-sugli-impianti-di-depurazione-di-acque-reflue-urbane/>.
- [69] G. Busetta, *Technical Report on Wastewater purification plant of Pantelleria*. Pantelleria, 2017. Accessed: Feb. 20, 2024. [Online]. Available: <https://www.comunepantelleria.it/gare/678350014A/R01%20Relazione%20Tecnica.pdf>.
- [70] S. Longo, et al., Monitoring and diagnosis of energy consumption in wastewater treatment plants. A state of the art and proposals for improvement, *Appl. Energy* 179 (2016) 1251–1268, <https://doi.org/10.1016/J.APENERGY.2016.07.043>. Oct.
- [71] S. Sipala, G. Mancini, F.G.A. Vagliasindi, Development of a web-based tool for the calculation of costs of different wastewater treatment and reuse scenarios, *Water Suppl.* 3 (4) (2003) 89–96, <https://doi.org/10.2166/WS.2003.0049>. Aug.
- [72] Price Indexes for Monetary Revaluations, "ISTAT - rivaluta - the national statistics institute." Accessed: Sep. 04, 2023. [Online]. Available: <https://rivaluta.istat.it/Rivaluta/Widget/tavoleWidget.jsp>.
- [73] Master Plan of Aqueducts, Sicily Region - PRGA - Piano Regolatore Generale degli Acquedotti, 2012. Italy Accessed: Sep. 04, 2023. [Online]. Available: <https://www.regione.sicilia.it/istituzioni/regione/strutture-regionali/presidenza-regione/autorita-bacino-distretto-idrografico-sicilia/prga-piano-regolatore-generale-acquedotti>.
- [74] European Union, *European regulation on minimum requirements for water reuse*. European Union: <http://data.europa.eu/eli/reg/2020/741/oj>, 2020. Accessed: Sep. 04, 2023. [Online]. Available: <https://eur-lex.europa.eu/eli/reg/2020/741/oj>.
- [75] V. Parravicini, K. Svardal, J. Krampe, Greenhouse gas emissions from wastewater treatment plants, *Energy Procedia* 97 (2016) 246–253, <https://doi.org/10.1016/J.EGYPRO.2016.10.067>. Nov.
- [76] Pantelleria Population, ISTAT - The National Statistics Institute, 2021. Accessed: Feb. 19, 2024. [Online]. Available: <http://dati.istat.it/Index.aspx?QueryId=18976>.
- [77] Tourism in Numbers, *Trend of Tourist Movement in the Pantelleria Municipality - Libero Consorzio Comunale di Trapani*, 2019. Accessed: Feb. 19, 2024. [Online]. Available: <http://www.consorziocomunale.trapani.it/provinciatp/zt/index.php/servizi-aggiuntivi/index/index/idxesto/147>.
- [78] "Measurement of The Organic Load in Wastewater in Italy." Accessed: Sep. 04, 2023. [Online]. Available: <https://www.acquerefue.it/bod-cod-e-toc-la-misura-del-carico-organico/>.
- [79] A. Siatou, A. Manali, P. Gikas, Energy consumption and internal distribution in activated sludge wastewater treatment plants of Greece, *Water* 12 (4) (2020) 1204, <https://doi.org/10.3390/W12041204>. Apr.
- [80] Palermo Today, "Inaugurato l'impianto di depurazione a Cefalù: 'Servizio per 45 mila abitanti,'" Palermo, Mar. 16, 2022. Accessed: Feb. 20, 2024. [Online]. Available: <https://www.palermotoday.it/cronaca/impianto-depurazione-cefalu-inaugurazione.html>.
- [81] V. Parravicini, P.H. Nielsen, D. Thornberg, A. Pistocchi, Evaluation of greenhouse gas emissions from the European urban wastewater sector, and options for their reduction, *Sci. Total Environ.* 838 (2022) 156322, <https://doi.org/10.1016/J.SCITOTENV.2022.156322>. Sep.
- [82] L.M. De Oliveira, S.M.O. Da Silva, F. de A. De Souza Filho, T.M.N. Carvalho, R. L. Frota, Forecasting urban water demand using cellular Automata, *Water* 12 (7) (2020) 2038, <https://doi.org/10.3390/W12072038>. Jul.
- [83] S.MED.E Pantelleria S.p.A., *Technical Report of the Pantelleria Power Plant - S. MED.E Pantelleria S.p.A.*, 2019. Accessed: Feb. 20, 2024. [Online]. Available: <https://www.smedepantelleria.it/>.
- [84] Clean Energy for EU Islands Secretariat, *Agenda for Energy Transition - Isola di Pantelleria, Bozza - Aggiornamento Luglio 2020*, 2022. Accessed: Feb. 19, 2024. [Online]. Available: <https://ef240db-8c22-45c7-8b08-93fc3f667cab/enhanced-reader.html?openApp&pdf=https://www.comunepantelleria.it/gare/678350014A/R01%20Relazione%20Tecnica.pdf>.
- [85] Italian Government, *The National Recovery and Resilience Plan*, Italy- NRRP, 2021. Accessed: Feb. 19, 2024. [Online]. Available: <https://www.mef.gov.it/en/focus/The-National-Recovery-and-Resilience-Plan-NRRP/>.
- [86] European Commission, "Italy: Ready to see water differently?" Accessed: Jan. 27, 2025. [Online]. Available: https://environment.ec.europa.eu/topics/water/water-wise-eu/italy_en.
- [87] G. Sabia, L. Sciuuba, L. Petta, Fronteggiare la siccità: il riutilizzo delle acque reflue depurate in agricoltura, *Focus ENEA* (2023), <https://doi.org/10.12910/EAI2023-011>. Nov.
- [88] Italian Parliament, *National legislative decree on procedures for the environmental impact assessment and authorization*. Italy: <https://www.parlamento.it/parlam/leggi/deleghe/06152dl.htm>, 2006. Accessed: Sep. 04, 2023. [Online]. Available: <https://www.gazzettaufficiale.it/dettaglio/codici/materiaAmbientale>.
- [89] R. Novo, F.D. Minuto, G. Bracco, G. Mattiazio, R. Borchellini, A. Lanzini, Supporting decarbonization strategies of local energy systems by de-risking investments in renewables: a case study on Pantelleria Island, *Energies* 15 (3) (2022) 1103, <https://doi.org/10.3390/EN15031103>. Feb.
- [90] D. Mosso, G. Colucci, D. Lerede, M. Nicoli, M.S. Piscitelli, L. Savoldi, How much do carbon emission reduction strategies comply with a sustainable development of the power sector? *Energy Rep.* 11 (2024) 3064–3087, <https://doi.org/10.1016/J.EGYR.2024.02.056>. Jun.
- [91] M. Nicoli, et al., Enabling coherence between energy policies and SDGs through open energy models: the TEMOA-Italy example, in: M. Labriet, K. Espregren, G. Giannakidis, B. O'Gallachoir (Eds.), *Aligning the Energy Transition With the Sustainable Development Goals: Key Insights from Energy System Modelling*, Springer, 2024, pp. 97–118, https://doi.org/10.1007/978-3-031-58897-6_5.
- [92] M.-A. Cassignol, Eyl-Mazzeza; Élise, *The geopolitics of seawater desalination*, Policy Cent. New South. Moroc. (2023). Accessed: Feb. 07, 2025. [Online]. Available: <https://coilink.org/20.500.12592/20md2x>.
- [93] N. Cruz-Pérez, J.C. Santamarta, I. Gamallo-Paz, J. Rodríguez-Martín, A. García-Gil, A comparison between carbon footprint of water production facilities in the Canary Islands: groundwater resources vs. seawater desalination, *Sustain. Water. Resour. Manage* 8 (4) (2022) 1–9, <https://doi.org/10.1007/S40899-022-00706-0/FIGURES/5>. Aug.
- [94] J.C. Santamarta, I.C. Rubiales, J. Rodríguez-Martín, N. Cruz-Pérez, Water status in the Canary Islands related to energy requirements, *Energy Effic.* 15 (2) (2022) 1–12, <https://doi.org/10.1007/S12053-021-10016-7/TABLES/5>. Feb.
- [95] ENEA, "Environment: Italy, over 40% lost to leaks in the supply system - Media." Accessed: Sep. 16, 2024. [Online]. Available: <https://www.media.enea.it/en/press-releases-and-news/years-archive/year-2023/environment-italy-over-40-lost-to-leaks-in-the-water-supply-system.html>.