

AperTO - Archivio Istituzionale Open Access dell'Università di Torino

**A new species of eagle (Aves: Accipitridae) close to the Steppe Eagle, from Pleistocene of Corsica and Sardinia, France and Italy.**

**This is the author's manuscript**

*Original Citation:*

*Availability:*

This version is available <http://hdl.handle.net/2318/80202> since

*Terms of use:*

Open Access

Anyone can freely access the full text of works made available as "Open Access". Works made available under a Creative Commons license can be used according to the terms and conditions of said license. Use of all other works requires consent of the right holder (author or publisher) if not exempted from copyright protection by the applicable law.

(Article begins on next page)

# A new species of eagle (Aves: Accipitridae) close to the Steppe Eagle, from the Pleistocene of Corsica and Sardinia, France and Italy

by

ANTOINE LOUCHART, CLAUDIA BEDETTI and MARCO PAVIA<sup>\*)</sup>

With 2 plates, 7 text-figures, 2 tables and 2 appendices

## Zusammenfassung

Diese Arbeit stellt neue Daten über fossile Adler der Gattung *Aquila* von Korsika und Sardinien vor. Es wird eine neue Art *Aquila nipaloides* n. sp. beschrieben. Diese ausgestorbene, großwüchsige Art steht der *A. nipalensis-rapax-heliaca-adalberti*-Gruppe nahe. Es handelt sich um den ersten fossilen Nachweis einer Art dieser Gruppe. Ein vollständiger Unterkiefer zeigt im Besonderen Ähnlichkeit mit *A. nipalensis*. Mehrere Elemente, wie das Femur, weisen artspezifische Apomorphien auf. Dies verstärkt den endemischen Charakter der pleistozänen Fauna dieser Inseln. Der Nachweis von *A. nipalensis* oder eines nahen Vorfahren, wenigstens in Teilen des europäischen Pleistozän, paßt gut in das Bild einer weit verbreiteten Tundren-Steppen-Umwelt. Es wird also notwendig sein, *A. nipalensis* bei Fossilbestimmungen im Pleistozän Europas in Betracht zu ziehen. Wir betonen nochmals die Unterschiedlichkeit von *A. rapax* und *A. nipalensis*. Weiterhin synonymisieren wir *Buthierax pouliani* KRETZOI, 1977 (Mittel-Pleistozän, Petralona, Griechenland) mit *Buteo rufinus jansoni* MOURER-CHAUVIRÉ, 1975b und betrachten *A. chrysaetos simurgh* WEESIE, 1988 (Jung-Pleistozän, Kreta, Griechenland) weiterhin als *Aves incertae sedis*, bis weitere Untersuchungen vorliegen.

Schlüsselwörter: *Aquila nipaloides* n. sp. – *Aquila nipalensis* – Pleistozän – Korsika – Sardinien.

## Summary

New data about fossil eagles of the genus *Aquila* from Corsica and Sardinia are presented. They lead to the description of *Aquila nipaloides* n. sp., an extinct species of large size, related to the *A. nipalensis-rapax-heliaca-adalberti* clade. The finds represent the first evidence of a member of this clade from the fossil record. A complete mandibula particularly shows its affinity with *A. nipalensis*. Some elements, like the femur, indicate specific apomorphies. This thus increases the endemism in the Pleistocene record of these islands. It also indicates the presence of *A. nipalensis*, or a close ancestor, in Europe during at least part of the Pleistocene. This is well in accordance with a widespread steppe-tundra environment. This fact also indicates that it will be necessary to take this species into account when identifying fossils from this period in Europe. It is emphasized again that *A. rapax* is much distinct from *A. nipalensis*. We here synonymize *Buthierax pouliani* KRETZOI, 1977 (Middle Pleistocene, Petralona, Greece) with *Buteo rufinus jansoni* MOURER-CHAUVIRÉ, 1975b, and we consider *A. chrysaetos simurgh* WEESIE, 1988 (Upper Pleistocene, Crete, Greece) as *Aves incertae sedis* pending further investigations.

Key words: *Aquila nipaloides* n. sp. – *Aquila nipalensis* – Pleistocene – Corsica – Sardinia.

\*) Addresses of the authors: Dr. A. LOUCHART, Université Claude Bernard Lyon 1, Bât. Géode, 27-43 bd du 11 novembre, 69622 Villeurbanne cedex, France, antoine.louchart@worldonline.fr – C. BEDETTI, Università "La Sapienza" of Roma, Dipartimento di Scienze della Terra, Piazzale Aldo Moro 5, 00185 Roma, Italy. – Dr. M. PAVIA, Università of Torino, Dipartimento di Scienze della Terra, Via Accademia delle Scienze 5, 10123 Torino, Italy.

## Table of contents

Zusammenfassung, Summary .....	121	1. Systematic implications .....	133
Introduction .....	122	2. Evolution and endemism .....	137
1. Materials .....	122	3. Paleobiogeography and paleoecology .....	139
2. Methods .....	124	Conclusions .....	140
Results .....	124	Acknowledgements .....	140
1. Identification at the generic level .....	124	References .....	140
2. Identification at the specific level .....	127	Appendix 1 .....	143
3. Systematic paleontology .....	131	Appendix 2 .....	144
Discussion .....	133	Explanation of the plates .....	148

## Introduction

Until now very little research has been published about the genus *Aquila* in particular and large eagles from the Pleistocene of Europe in general. C. MOURER-CHAUVIRÉ (1975a) described the fossil subspecies *A. chrysaetos bonifacti* from the Middle Pleistocene of France; more recently, P.D.M. WEESIE (1988) described *A. chrysaetos simurgh* from the Upper Pleistocene of Crete, Greece. He also preliminarily studied some *Aquila* remains from the Upper Pleistocene of Sardinia (WEESIE 1999, and unpubl. data).

New data from the Pleistocene of Corsica and Sardinia (LOUCHART 2001b, 2002), and hitherto unpublished data about Sardinia allow us to propose some new interpretations, and the description of a new species, along with some implications.

Corsica and Sardinia were linked together in a Corso-Sardinian block during most of the Pleistocene on account of the low sea level. Therefore, we consider the contemporaneous fossils from these two islands as belonging to the same biogeographical entity, and a priori to represent the same taxa.

## 1. Materials

The fossil material analysed here is deposited in the following collections:

The material from Dragonara Cave is stored in the Museo di Paleontologia of the Università "La Sapienza" of Roma, Italy (MPUR). The material from the Castiglione 3 and Coscia sites is currently stored at Université Claude Bernard – Lyon 1, Villeurbanne, France (UCBL), and will be transferred to Corsica when the Museum at Sartène is ready. The material from Corbeddu and Rapaci is stored at the Natuurmuseum Rotterdam, Netherlands.

The fossils come from different localities in Corsica (Coscia and Castiglione 3), and Sardinia (Corbeddu, Dragonara and Rapaci Caves) (Text-fig. 1). The fossil assemblages in which the *Aquila* remains were found are mostly Late Pleistocene in age and are cave deposits or fissure fillings.

Coscia Sites (Macinaggio, Cap Corse): Both the Cave (abbreviated Cos) and the Shelter (abbreviated M) have yielded thousands of bird remains of early Late Pleistocene age (ca. 60 000 to 90 000 years BP; BONIFAY et al. 1998, LOUCHART 2001b, 2002). The cave and shelter are connected, and their fillings are from the same period. The accumulations are natural, i.e. non-anthropogenic, as far as birds are concerned. Most of the remains of small birds probably derive from regurgitation pellets of owls, whereas the eagle remains may come from individuals that died close to the cave, where they'd had a roost or a nest. The birds other than eagles are very numerous and diverse (more than 80 taxa altogether; LOUCHART 2001b, 2002). The remainder of the fauna consists mainly of the endemic deer *Megaceros (Nesoleipoceros) cazioti* and other endemic mammals (including *Prolagus sardus*, *Cynotherium sardous*, and three species of micromammals; PEREIRA 2001a).

Castiglione 3 Fissures (Oletta, Golfe of Saint-Florent) (abbreviated Cast3): The different sites of this locality consist of large, primarily tectonic fissure fillings (PEREIRA et al. 1999). The accumulation is natural, from regurgitation pellets of owls to *in situ* deaths of saxicolous birds. The eagle remains come mainly from the Late Pleistocene-Early Holocene group of localities (loci abbreviated Cast3PL sensu lato = Cast3PL s.l.: dated 17000 to 9000 BPcal) (SALOTTI et al. 2000, LOUCHART 2001b, 2002). The avifaunas from the Castiglione fissures are

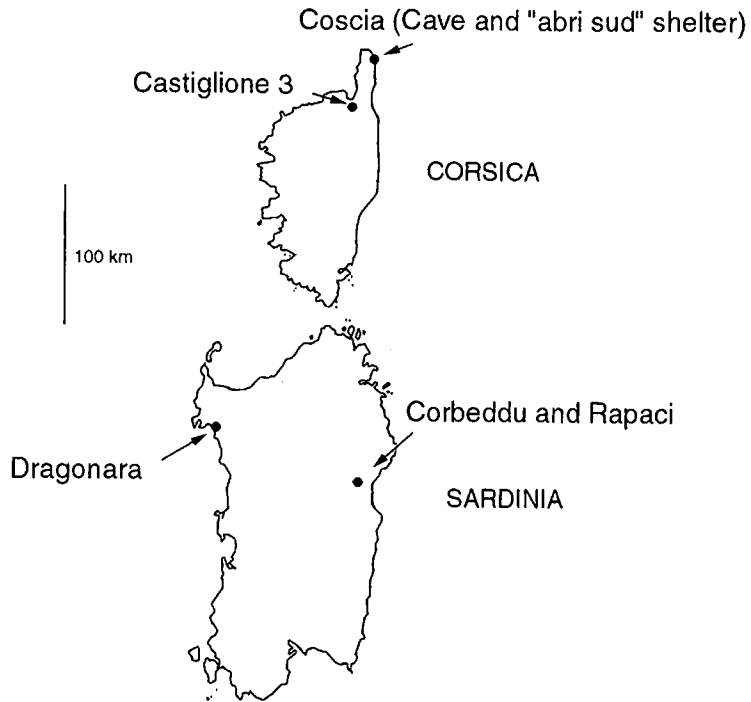

Text-Fig. 1. Location map of the fossiliferous sites.

abundant and diverse (LOUCHART 2001b, 2002), and the mammals comprise many species, including several endemic, and several recently described species (see PEREIRA 2001b). One tarsometatarsus comes from the Middle Pleistocene locality Cast3CG6, and can be dated around 200 000 – 400 000 BP (other remains from Cast3CG s.l. are dated around 200 000 – 250 000 BP; see SALOTTI et al. 1997, PEREIRA 2001a). However, this specimen is provisionally included in the hypodigm. It is particularly large but can be referred to the new species described here.

As for the Coscia site, the remains of eagles probably derive from individuals that had had a roost or a nest in or near some of the originally open fissures.

Dragonara Cave (abbreviated MPUR): This locality consists of a single cave, opening up at the present-day sea level in the eastern part of Capo Caccia promontory, near Alghero, NW Sardinia. Underneath the gravel and stalagmite deposits, the cave contains a 60 cm thick bed of red clay very rich in vertebrate remains, that overlies a fossil beach of the Late Pleistocene. The vertebrate deposit was correlated with another bed cropping out outside the cave and dated to the Late Pleistocene by MALATESTA (1970), specifically to the last glacial event. The fossil vertebrates are very abundant with mostly bird and mammal remains. The bird association comprises more than 700 remains attributed to at least 25 taxa, to the most part referable to diurnal raptors (MALATESTA & SURIANO 1970). The mammal association includes abundant remains of *Cynotherium sardous* and *Megaceros (Nesolopoceros) cazioti* and other endemic species, mostly micromammals (MALATESTA 1970).

Corbeddu Cave (abbreviated CB): Numerous eagle remains, mainly pedal phalanxes but also fragmentary long bones, were found in this Upper Pleistocene cave filling of Sardinia. Many were identified as *Aquila chrysaetos*, but a few as *Aquila cf. heliaca* (WEESIE 1999). The accumulation was thought by WEESIE (1999) to be of anthropogenic origin. This hypothesis, based on patterns of representation of the elements and fragmentation, will not be discussed here and has no significance to our focus (but see LOUCHART 2001b, 2002).

Rapaci Cave (abbreviated Rp): A great number of pedal phalanxes and some fragmented long bones of eagles were found in this Upper Pleistocene cave of Sardinia, and a preliminary unpublished study was made by WEESIE. The pattern of representation of the elements and their fragmentation are very similar to those observed at Corbeddu.

## 2. Methods

The fossil remains were directly compared with all the Western Palearctic species of the genus *Aquila*: the Lesser Spotted Eagle *A. pomarina* BREHM, the Greater Spotted Eagle *A. clanga* PALLAS, the Tawny Eagle *A. rapax* (TEMMINCK), the Steppe Eagle *A. nipalensis* HODGSON, the Imperial Eagle *A. heliaca* SAVIGNY, the Spanish Eagle *A. adalberti* BREHM, and the Golden Eagle *A. chrysaetos* (L.). We also compared them with the large European eagle of the genus *Hieraaetus*, Bonelli's Eagle *H. fasciatus* (VIEILLOT). Moreover, we compared the fossils with the other genera of extant eagles and other large birds of prey from around the world, as well as with the extra-Palearctic *Aquila* species. The recent comparative material came from different collections, in particular from the Natural History Museum, Tring (BM), the Hungarian Museum of Natural History, Budapest (H), the collection in Anatomie Comparée, Muséum National d'Histoire Naturelle, Paris (AC), the Institut de Paléontologie Humaine, Muséum National d'Histoire Naturelle, Paris (IPH), the Institut Royal des Sciences Naturelles de Belgique, Bruxelles (IRSN), the Zoological Museum of the University of Copenhagen (ZMUC), the Museum "La Specola", Florence (MF), the Museo Civico di Storia Naturale di Carmagnola (MCCI), the University of Michigan Museum of Zoology (UMMZ), the National Museum of Natural History, Smithsonian Institution, Washington, D.C. (USNM), the Marco Pavia Osteological Collection, University of Torino (MPOC), the private Collection of Patrick Bayle, Marseille (PB), and the collections of Université Lyon 1 - Claude Bernard (UCBL). The specimens analysed are listed in Appendix 1. The measurements of specimens from IRSN, ZMUC, UMMZ and USNM were provided by S.J. PARRY (pers. com.). Measurements of Budapest specimens were provided by E. GAL (pers. com.). Some recent skeletal specimens of *A. chrysaetos* from Corsica were made available in the AC collection by J.-C. Thibault.

We considered then all the fossil *Aquila* species and other large extinct eagles hitherto described around the world.

The systematics adopted here follow DEL HOYO et al. (1994). The osteological nomenclature is that proposed by BAUMEL & WITMER (1993). The way the measurements were taken is shown in Text-fig. 2. All the measurements are in mm, with a margin of error of  $\pm 0,05$  mm.

## Results

### 1. Identification at the generic level

The frequent lengthening of hindlimbs in insular birds (GRANT 1965), with many examples in Strigiformes and also in Falconiformes (WEESIE 1982, OLSON & JAMES 1991, MOURER-CHAUVIRÉ et al. 1994, SUAREZ & OLSON 2001, LOUCHART 2001b), shows the need to avoid such criteria as hindlimb proportions to detect phylogenetic relationships in extinct insular forms. The same applies to forelimb elements which may tend to be reduced in length on islands. Forelimb reduction is seen in many cases of reduced or lost flight ability (see e.g. OLSON 1983, LIVEZEY 1990, OLSON & JAMES 1991, DIAMOND 1991, LOUCHART 2001b). Such limb modifications relative to the rest of the body are in addition either isometrical or allometrical themselves (changes in dimensions of the limb elements relative to each other, and of the elements proportions themselves). Therefore it is necessary to look for a set of different criteria covering most of the skeleton, and to determine if these converge toward a single taxonomic identification.

Apart from the vultures of the genera *Gyps*, *Aegypius* and *Gypaetus*, and the Sea Eagles *Haliaeetus* spp., the genus *Aquila* comprises some of the largest diurnal birds of prey of the Western Palearctic. The eagles are osteologically well defined and easily separated from these birds by certain morphological characteristics in almost all the skeletal elements. They are often called "booted eagles" and in the Palearctic belong to the genera *Aquila* and *Hieraaetus*.

**mandibula**

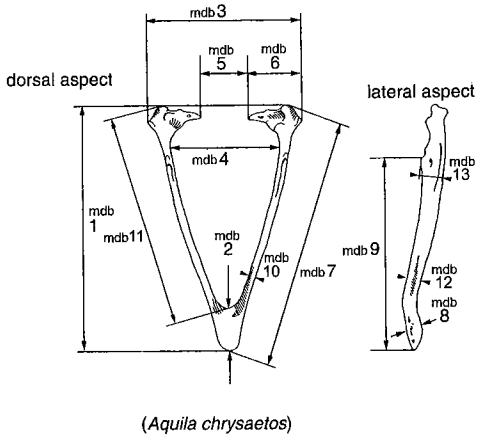

**humerus**

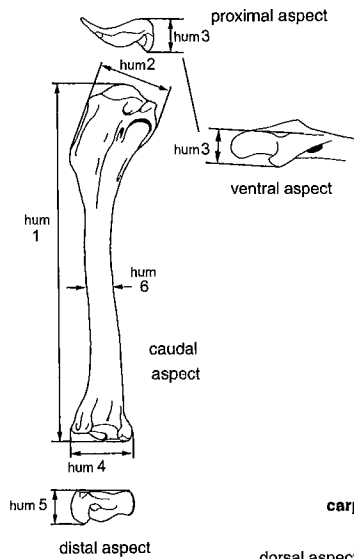

**ulna**

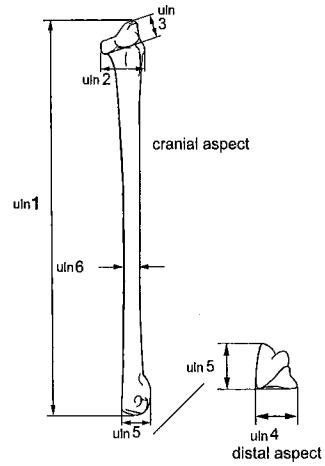

**coracoid**

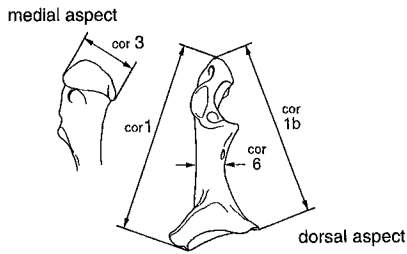

**carpometacarpus**

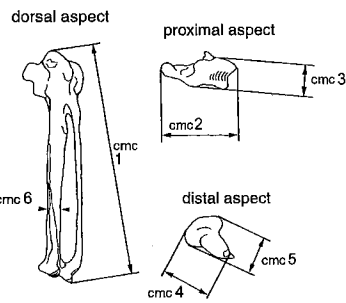

**femur**

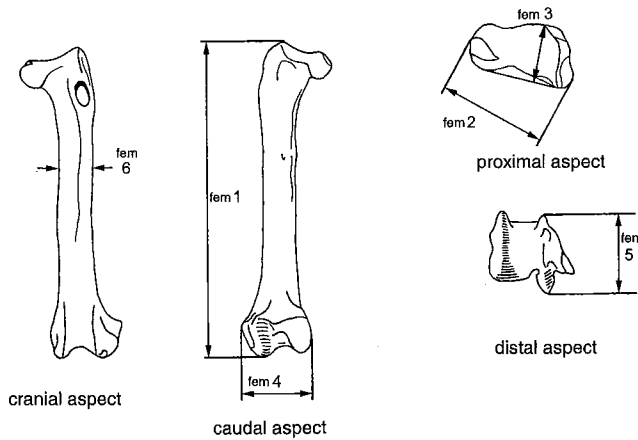

**tibiotarsus**

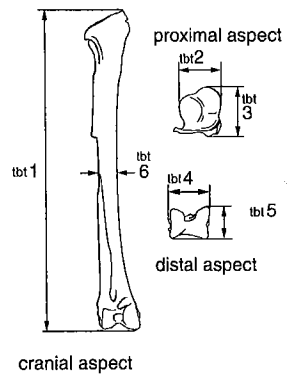

**tarsometatarsus**

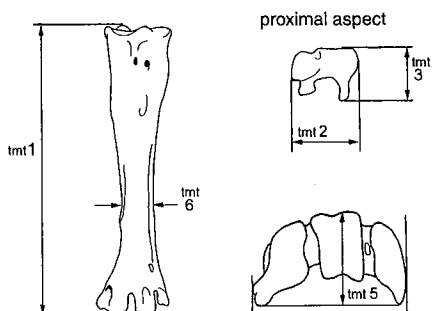

**phalanx 1 of digit I**

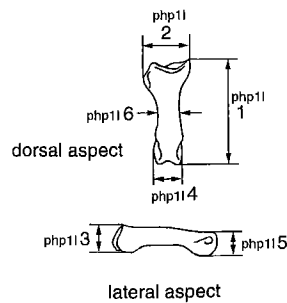

**phalanx 2 of digit I**

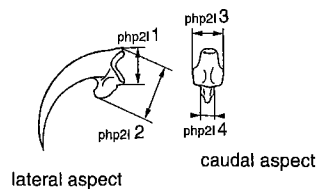

America, the last in New Guinea). Moreover, *Spizastur* is a very small eagle. *Pithecophaga jefferyi* shows a robust tarsometatarsus with a very thick diaphysis and a trochlea II much more developed than in *Aquila*, a robust mandibula with straight rami, and a robust femur. *Ictinaetus malayensis* shows, reminiscent of *nipaloides*-related *Aquila* species, somewhat bowed rami of the mandibula which is very small; but the femur and tarsometatarsus are very small, and the tarsometatarsus has a trochlea II relatively much more developed than in *Aquila*. *Polemaetus bellicosus* shows a robust mandibula with straight rami; its tarsometatarsus differs mainly in the trochlea III being about one third more developed proximally than in *Aquila* relatively to the other trochleae; the femur is quite robust. Some informations about *Polemaetus* were provided by C. MOURER-CHAUVIRÉ (pers. com.; specimen USNM 430533). *Lophaetus occipitalis* shows a mandibula with sometimes slender and bowed rami, but its tarsometatarsus is very small and very slender with a reduced trochlea IV. The tarsometatarsus shows a very well marked ridge at the proximal half of the tarsometatarsus dorsally and medially to the sulcus extensorius. Finally, the femur is quite robust. The species of *Spizaetus* have a robust mandibula with straight rami. Their tarsometatarsus is small and with narrow epiphyses. The femur is slightly more robust. *Stephanoaetus coronatus* shows a extremely short and robust tarsometatarsus, with a wide diaphysis and robust trochleae; its mandibula is robust with straight rami; and the femur is very robust.

Among these genera, *Morphnus*, *Harpia*, *Spizastur*, and *Oroaetus* are neotropical. *Harpyopsis*, *Pithecophaga*, and *Ictinaetus* live in New Guinea, the Philippines, and South East Asia, respectively. *Polemaetus*, *Lophaetus*, *Spizaetus*, and *Stephanoaetus* are at least partly African (sub-Saharan Africa), thus being closer to Europe and a priori candidates regarding the identity of the fossils, but can be excluded from consideration due to the important morphological differences discussed above.

Therefore it appears from the mandibulae evidence, characteristics of the femora and tarsometatarsi, and biogeographical considerations that the new species belongs to the genus *Aquila*.

Incidentally, SEIBOLD (1994) concluded from molecular evidence that the genus *Aquila* is paraphyletic and that *Hieraetus* is polyphyletic. This author suggests that *Hieraetus*, *Polemaetus*, and *Aquila* should be merged into a single genus based on molecular distances. Moreover, *Hieraetus fasciatus* was found to be close to *A. verreauxii* which in turn is closer to *A. chrysaetos* than the latter is to other Palearctic species. Our osteological observations are in accordance with this phylogeny, which explains the similarities we observe between *H. fasciatus* and *A. chrysaetos*.

## 2. Identification at the specific level

The Palearctic *Aquila* eagles considered here can be subdivided into three groups based on osteological and other morphological features. These groups appear to have a phylogenetic validity.

One group includes *A. nipalensis*, *A. rapax*, *A. heliaca*, and *A. adalberti*. The latter is considered as a separate species closely related to *A. heliaca* following SEIBOLD (1994), DEL HOYO et al. (1994), CRAMP & SIMMONS (1998), and SANGSTER et al. (2002). All these species but *A. rapax* share the bowed rami of the mandibula, a character that is most pronounced in *A. nipalensis* (Plate 2; OLSON 1994). All also share the bridge of bone across the nostril (pers. obs.; PARRY, pers. comm.), which is not only present in *A. nipalensis* and *A. rapax*, the only two species examined by OLSON (1994). And all but *A. rapax* normally lack a fenestra in the interorbital septum (OLSON 1994, for *A. rapax* and *A. nipalensis*; PARRY, pers. comm.). Intraspecific variation in this character may occur however, see e.g. the specimen *A. nipalensis* BM 1923.9.3.2, which bears this fenestra.

The rami of the mandibula in *A. nipalensis* are considerably longer than in *A. rapax* (as well as in *A. chrysaetos*). This leads to the greater width of the gape in *A. nipalensis* (CLARK 1992). This feature is even known as a useful criterion in the field when it is possible to see it: Steppe Eagles have the yellow gape line extending to below the posterior margin of the eye but never this far in the other Western Palearctic *Aquila* species (JONSSON 1992, BEAMAN & MADGE 1998). Thus *A. heliaca* and *A. adalberti* are closer to *A. nipalensis* than *A. rapax* is in this respect. As suggested by CLARK (1992) and OLSON (1994), *A. nipalensis* and *A. rapax* are very distinct and at least not conspecific (contra e.g. CRAMP & SIMMONS 1998). Their specific distinction is now widely acknowledged (e.g. SANGSTER et al. 2002, PARRY et al. 2002).

Further, the mandibula of *A. heliaca* does not appear to reach the size of the largest *A. nipalensis*, has typically somewhat less bowed rami, and has a proportionately longer symphysis (for comparisons of mandibulae, see Appendix 2, and Plate 2).

The morphological character cited by SANGSTER et al. (2002) to propose that *A. nipalensis* and *A. rapax* are sister-species is the one cited by OLSON (1994): a bridge of bone across the nostril. But actually, *A. heliaca* and *A. adalberti* also share this characteristic (see above). Both molecular (SEIBOLD 1994) and morphological and behavioral evidence (PARRY, pers. comm.) support a clade consisting of *A. nipalensis*, *A. rapax*, *A. heliaca*, and *A. adalberti*. Molecular data suggest that *A. nipalensis* is the sister species of a clade formed of *A. rapax* and the two sister species *A. heliaca* and *adalberti* (SEIBOLD 1994). This confirms that these last two are very closely related, but separate, species, and that there is actually no support for a sister group relationship of *A. rapax* and *A. nipalensis*, contra OLSON (1994) or SANGSTER et al. (2002); an *A. rapax-nipalensis* group would be paraphyletic. The shared features of these two species (such as juvenile plumage) could be plesiomorphic.

The second group comprises *A. chrysaetos* alone. The Golden Eagle is the only one of those considered here to live outside the Old World. It is very variable osteologically and osteometrically, as probably most of the other species of the genus would appear to be if more material was to be examined. *A. chrysaetos* is the largest species, but some individuals of *A. nipalensis* are of similar body size (possibly the subspecies *nipalensis*). However, the mandibulae of *A. chrysaetos* are smaller than the otherwise smaller species of the first group. They have relatively short, wide, thick and straight rami and a long symphysis. The rami of the Golden Eagle are also thicker and wider than in the first group. As we emphasized above, the mandibula of *A. chrysaetos* is morphologically closer to that of *Hieraetus fasciatus* than to that of congeneric large Palearctic eagles which is congruent with molecular data (SEIBOLD 1994).

We note that *Aquila chrysaetos* is distinct from the *A. nipalensis-heliaca-adalberti* group, and even *A. rapax*, by having more developed pedal phalanges relatively to the rest of the skeleton. However, this being subject to frequent insular modification, like other inter-element allometrical features, it will be useful here only as a subsidiary character for identifications.

The third group of species comprises *A. clanga*, *A. pomarina*, and *A. hastata* (PARRY et al. 2002). These small *Aquila* species share distinctive plumage features and rounded nasal orifices (GÉROUDET 1965-1984), not elongated as in the other groups. They share many other morphological and molecular synapomorphies (e.g. SEIBOLD 1994). Their small size alone largely prevents confusion with the other eagles. *A. hastata* will be considered below. *A. clanga* and *A. pomarina* will not be considered further here because of their small size

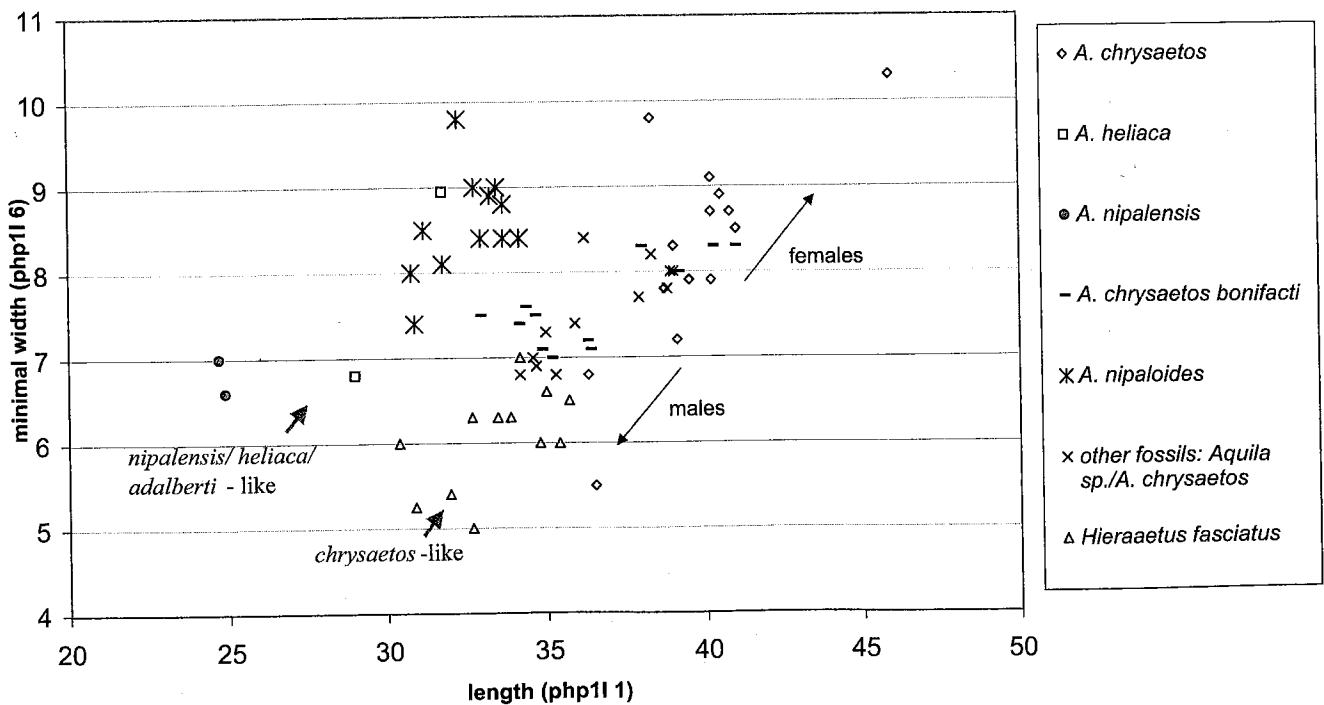

Text-Fig. 4. Scatter diagram showing the distribution of the pedal phalanges 1 of digit I, according to their total length (1) and their minimal width (6), in the fossils and in different large living eagles.



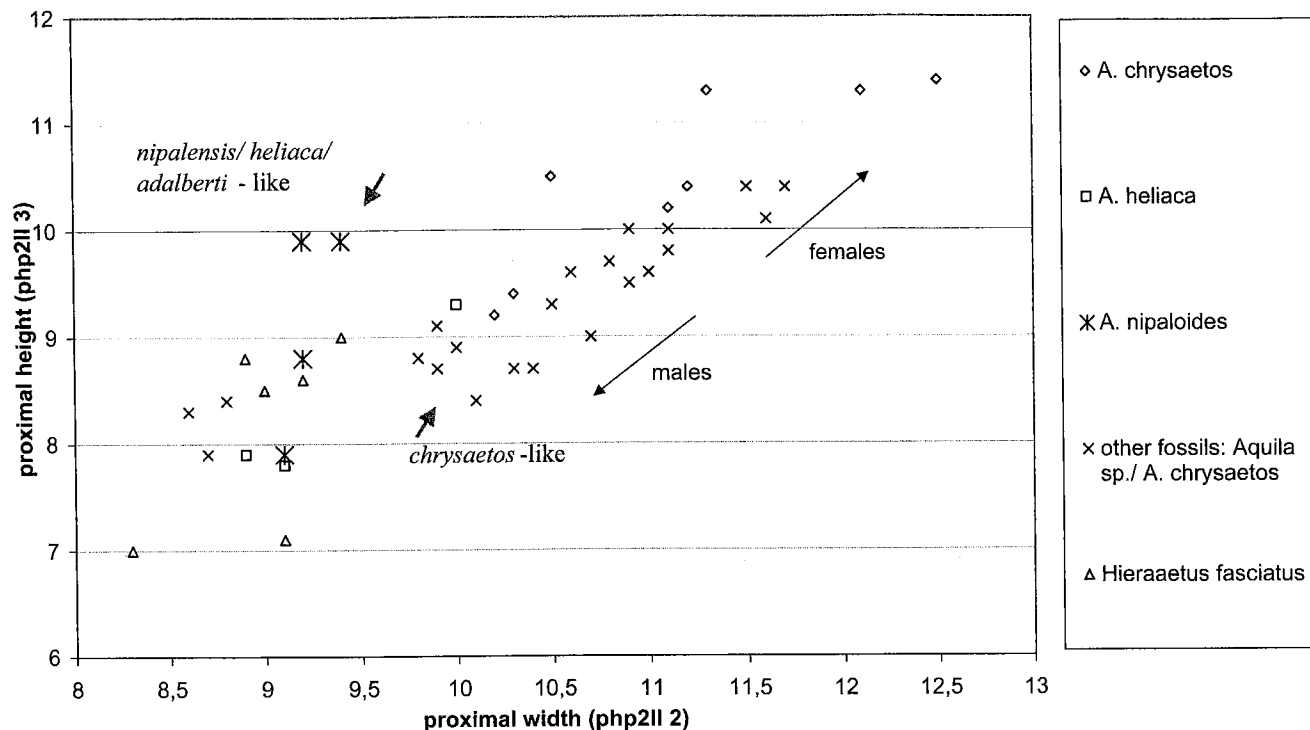

Text-Fig. 5. Scatter diagram showing the distribution of the pedal phalanxes 2 of digit II, according to their proximal width (2) and their proximal height (3), in the fossils and in different large living eagles.

and their short and straight mandibular rami. From a molecular phylogenetic point of view, this clade appears to be the sister group of the *nipalensis-rapax-heliaca-adalberti* clade.

The other living *Aquila* species in the world are different from the fossils. *Aquila wahlbergi* lives in sub-Saharan Africa; it is very small, its mandibula has straight rami, and its tarsometatarsus has a narrow diaphysis. *A. verreauxii* lives in the same region and also in the Near-East. It has a robust mandibula with straight rami, a more robust femur, and a thicker diaphysis of the tarsometatarsus. *A. audax* is Australian; it shows the same differences as *A. verreauxii*. As above, all these remarks are made in comparison to *A. nipaloides* n. sp. *A. gurneyi* was not examined, but it lives in New Guinea and adjacent islands, thus being the least probable species for comparison.

Without cranial elements, size and the proportions of some pedal phalanxes remain the only ways of differentiating the taxa in some cases. *A. chrysaetos* is postcranially the largest, followed by *A. nipalensis*, *A. heliaca* and *A. adalberti*, *A. rapax* (and *H. fasciatus*), and *A. clanga*. *A. pomarina* is the smallest. The proportions of the pedal phalanxes 1 of digit I, 2 of digit I, and 2 of digit II allow in most cases the distinction between the *A. nipalensis - A. rapax - A. heliaca - A. adalberti* group and *A. chrysaetos* (which can be sometimes closer to *H. fasciatus* in these regards). The overall size being close among *Aquila chrysaetos*, *A. nipalensis*, *A. heliaca*, and *A. adalberti*, the pedal phalanxes of the first are more elongated than those of the three others (Text-figs 4, 5, Appendix 2).

For these reasons, many of the postcranial fossils from the sites considered in this work were thus identified only as *Aquila* sp. indet.

Most of the Western Palearctic *Aquila* eagles show a relatively moderate reverse size dimorphism (RSD) between males and females (females being larger than males). Individual variation in size is far greater than this dimorphism and also than inter-populations variation.

Only *A. heliaca* and *A. chrysaetos daphanea* show more than 30% difference, and all the other western Palearctic *Aquila* spp. other than *A. pomarina* show less than 20% size difference between sexes. Based on body weights of living birds (CRAMP & SIMMONS 1998) the mean weights and male/female ratios are shown in Table 1.

Table 1. Average weights of male and female living Western Palearctic eagles, and male/female ratios. After CRAMP & SIMMONS (1998).

Taxon	Mean weight of males (g)	Mean weight of females (g)	Male/female ratio (%)
<i>Aquila chrysaetos daphanea</i> (part of Eastern Palearctic)	4050 n=2	6350 n=1	63,8
<i>Aquila chrysaetos</i> other Palearctic subspecies	3648 n=18	4416 n=22	82,6
<i>Aquila pomarina</i>	1257 n=6	1693 n=12	74,2
<i>Aquila clanga</i>	1770 n=3	2135 n=4	82,9
<i>Aquila nipalensis orientalis</i>	2459 n=13	2987 n=18	82,3
<i>Aquila nipalensis nipalensis</i>	3010 n=2	3575 n=2	84,2
<i>Aquila rapax rapax</i>	1839 n=5	2155 n=5	85,3
<i>Aquila rapax belisarius</i>	2004 n=1	2242 n=2	89,4
<i>Aquila heliaca</i>	2624 n=5	3901 n=5	67,3
<i>Aquila adalberti</i>	average slightly larger than <i>heliaca</i> , especially in males		
<i>Hieraaetus fasciatus spilogaster</i> (Africa south of Sahara)	1221 n=1	1553 n=2	78,6
<i>Hieraaetus fasciatus fasciatus</i>	1860 n=2	2250 n=2	82,7

Because of these small differences we chose not to consider the sexes separately in recent comparative material. In addition, sexing information is often missing.

Nevertheless, our large sample of pedal phalanxes, particularly from the Sardinian sites of Corbeddu and Rapaci, allows us to detect sexual size dimorphism, and we can identify most individuals as males or females in both the species present. This is of great help in the difficult task of differentiating between species (Text-figs 4, 5).

The analysis of the fossil remains first dealt with a differential appraisal in order to identify the number of taxa represented. Next, we attributed as many remains as possible to one of these groups on account of some morphological characters, proportions of the element, and sometimes its size. The other bones were referred to *Aquila* sp. indet.

Diagnostic remains belonging to *A. chrysaetos* are present in every site except for Castiglione. Diagnostic remains of an *A. nipalensis*-related species are present in every site. Diagnostic remains showing characteristics justifying the creation of a new species with affinities to *A. nipalensis* (especially femora and tarsometatarsi as well as humeri) are present in the following sites: Coscia, Castiglione and Dragonara. For all these morphological categories, the distribution of the same skeletal elements (Table 2) shows that the best explanation is that two species were living together in the vicinity of each site, at least during the Late Pleistocene: *A. nipaloides* n. sp. and *A. chrysaetos*. We can exclude the possibility of one species exhibiting a high sexual dimorphism because of both the differences in morphology and in the proportions of some elements, as demonstrated below. Moreover, the pedal phalanxes clearly represent males and females of two species (see above, Text-figs 4, 5). For several reasons we also exclude the possibility that a third species of large eagle is represented by these fossils: it is very unlikely

Table 2. Distribution of the elements belonging to three morphological categories in the different sites. The first two categories correspond to *Aquila nipaloides* n. sp.

Morphology\Site	Coscia	Castiglione PLSI	Grotta Rapaci	Grotta Corbeddu	Dragonara
<i>A. nipalensis</i> - like	mandibulae; tarsometatarsi; pedal phalanxes	tarsometatarsi	pedal phalanxes	pedal phalanxes	tarsometatarsi
<i>Aquila</i> n. sp. showing affinities with <i>A.</i> <i>nipalensis</i>	humeri				humeri; femurs
<i>A. chrysaetos</i>	humeri; pedal phalanxes		pedal phalanxes	pedal phalanxes	humeri; femurs; tarsometatarsi

that beside *A. chrysaetos* and *A. nipalensis*, this third, new species would be represented only by elements not recorded for *A. nipalensis* (Table 2). The affinities to *A. nipalensis* shown by some of these elements would indicate two species of the *A. nipalensis-rapax-heliaca-adalberti* clade together with *A. chrysaetos*, and this would be far too many, even considering migrating eagles in spring and fall, given the limited amount of fossils.

Hereafter we provide the description of the new species, a relative of *A. nipalensis*.

### 3. Systematic paleontology

#### Order Falconiformes SHARPE

#### Family Accipitridae (VIEILLOT)

#### Genus *Aquila* BRISSON

#### *Aquila nipaloides* n. sp.

Plate 1, figs 1, 2, 3, 4, 5, 6, 8, 9; Plate 2, fig. 1

- pars 1970 *Aquila chrysaetos* (L.) – MALATESTA & SURIANO.  
 pars 1992 *Aquila* cf. *heliaca* SAVIGNY – ALCOVER et al., p. 276, tab. 1.  
 pars 1997 *Aquila chrysaetos* (L.) – MOURER-CHAUVIRÉ in SALOTTI et al., p. 71, tab.  
 pars 1998 «Grand Accipitridé gen. et sp. indet.» – MOURER-CHAUVIRÉ and LOUCHAR in BONIFAY et al., pp. 28, 30.  
 pars 1999 *Aquila chrysaetos* (L.) – WEESIE, pp. 401–409, pars fig. 1 et 2.  
 1999 *Aquila* cf. *heliaca* SAVIGNY – WEESIE, pp. 401–409.  
 1999 *Hieraaetus fasciatus* (VIEILLOT) – MOURER-CHAUVIRÉ in THIBAUT & BONACCORSI, p. 36.  
 pars 2000 *Aquila* n. sp. – LOUCHAR in SALOTTI et al., pp. 219–221, tab. 1, p. 223.  
 2001a *Aquila* nov. sp. – LOUCHAR, pp. 345–354.  
 2001b *Aquila* nov. sp. – LOUCHAR, pp. 44, 62–64, 208, 210, 220–222, 228, 291, tab. 42–51, fig. 10, pl. 4 fig. 1–4.  
 2001c *Aquila* nov. sp. – LOUCHAR, pp. 190, 198, tab. 1, 2, 4, 5.  
 2001 *Aquila* nov. sp. – MOURER-CHAUVIRÉ et al., p. 232.  
 2002 *Aquila* nov. sp. – LOUCHAR, pp. 34, 44–46, 136, 138, 139, 146, 147, 151, 157, tab. 44–53, 193, 196, 198, 200, 202, 203, pl. 4, fig. 3–6.

Holotype: Complete right femur MPUR 4297 from Dragonara Cave (see Text-fig. 1), near Alghero, NW Sardinia, Italy.

Paratypes: Complete mandibula M 50-51, left ramus of mandibula Cos 1780; complete right humerus MPUR 4369, proximal right humerus MPUR 4359, distal right humerus MPUR 4363, distal right humerus MPUR 4367, complete left humerus MPUR 4358; complete right ulna MPUR 4329, complete left ulna MPUR 4347, proximal left ulna MPUR 4339; complete left femur MPUR 4298; complete left tarsometatarsus MPUR 4286, complete right tarsometatarsus Cast3 1132 from the locality Cast3PL s.l., proximal left tarsometatarsus Cos 4335, distal left tarsometatarsus Cos 5658, and most probably corresponding proximal left tarsometatarsus Cos 8676; complete pedal phalanxes 1 of digit I CB 861678, CB 84 A28, CB 112, RP 256, RP 257, RP 111, RP 116, RP 110, RP II 2, MPUR 4934, MPUR 4935, MPUR 4936, Cos 4466; complete pedal phalanxes 2 of digit ICB I 202, CB 84A123, RP 120, RP 119, RP 123, RP 258, MPUR 4924, Cos 6229; complete pedal phalanxes 2 of digit IICB 84A171, CB 84A082, RP 155, RP II 7, RP II 6; complete pedal phalanx 4 of digit III CB 101.

Hypodigm: All the rest of the identified bones: see Appendix 2.

Etyymology: From *nipalensis*, and the greek suffix *oides*, which means having the appearance of, on account of the close relation of the new species with *A. nipalensis*, shown by several morphological characteristics.

Type locality: Dragonara Cave, Capo Caccia near Alghero (NW Sardinia) (Text-fig. 1).

Additional localities: Corbeddu Cave and Rapaci Cave in Sardinia; Coscia cave and “Abri sud”, and Castiglione 3 fissure fillings in Corsica (Text-fig. 1).

Age: Generally Late Pleistocene. Middle Pleistocene for Cast3 680 from Cast3CG s.l. (see SALOTTI et al. 1997, LOUCHART 2001b, 2002). This specimen is included here provisionally in the hypodigm. N.B.: The age is not only Middle Pleistocene as stated erroneously in MOURER-CHAUVIRÉ et al. (2001). The new species was also erroneously listed as an extant species (under the name ‘*Aquila* nov. sp.’) in one table (both in LOUCHART 2001c: tab. 5; and in LOUCHART 2002: tab. 203).

Differential diagnosis: Species of *Aquila* with a very slender femur, more slender than in any other *Aquila* species. Femur as long as in *A. chrysaetos* but thinner, and as thin as in *A. nipalensis* but longer. Femur epiphyses especially thin relatively to the diaphysis.

Measurements: The measurements of the *A. nipaloides* n. sp. remains, along with those of extant species taken for comparison, are listed in Appendix 2.

Description and comparisons: The rami of the mandibula of *Aquila nipaloides* n. sp. are relatively and absolutely longer than the ones of *A. chrysaetos* and are clearly more bowed, most similar to the condition in *A. nipalensis* (Plate 2, Appendix 2).

The following descriptions of postcranials are made in comparison with the living Palearctic *Aquila* species, unless otherwise stated.

The humerus of *Aquila nipaloides* n. sp. is the size of that of *A. chrysaetos* or *A. nipalensis*. It can be distinguished by the more pronounced caput humeri and a well defined depression, in the middle of the cranial side of the proximal epiphysis, close to the sulcus ligamenti transversus. In the caudal surface of the proximal epiphysis, a shallow and elongated depression is present dorsally to the crus dorsale fossae and ventrally to the margo caudalis. In the distal part of the humerus, the fossa musculi brachialis is better defined in living Palearctic *Aquila* spp. than in *A. nipaloides* n. sp., as is also the processus flexorius. In the distal epiphysis, the processus supracondylaris dorsalis is much better developed in *Aquila nipaloides* n. sp., and the epicondylus dorsalis is also better defined and more protruding in the new species. The humerus of *A. nipaloides* n. sp. is more slender than that of *A. chrysaetos* and more similar to that of *A. nipalensis* and *A. heliaca*. Figs 1 and 2 of Plate 1 show two humeri of *A. nipaloides* n. sp. They seem to be very distinct in size but actually fit well with a large female and a small male of the species respectively. The small one is 166 mm long, the large one 219,7 mm. In recent *A. chrysaetos*, presumably all from the Western Palearctic, 26 individuals show extremes of 166 mm and 225 mm. The fossil humeri thus show no exaggerate dimorphism in this regard. Furthermore, the size dimorphism appears greater in the recent *A. nipalensis* than in the nominate west Eurasian *A. chrysaetos* (PARRY, pers. comm.). Therefore, the close relationship of the fossil species to the Steppe Eagle also indicates a potentially greater sexual size dimorphism, and nothing prevents us from interpreting these two humeri as belonging to the same species.

The ulna of *Aquila nipaloides* n. sp. (Plate 1, fig. 4) is also as large as in some *A. chrysaetos* or *A. nipalensis*, but it is proportionately more slender than in *A. chrysaetos*. The mean dimensions seem large (Text-fig. 3), but there is probably an over-representation of large, female individuals here. In the proximal part of the ulna of the fossil species, there is a gap between the tuberculum ligamenti collateralis ventralis and the cotyla ventralis, while in the Palearctic living *Aquila* spp. the tuberculum ligamenti collateralis ventralis lies directly under the cotyla ventralis. In the distal part (Plate 1, fig. 3), the condylus dorsalis ulnaris is oblique in cranial view with respect to the major axis of the bone in *Aquila nipaloides* n. sp. not parallel to the caudal side of the shaft, and fuses proximally with the diaphysis at mid-point of the latter dorsoventrally. The tuberculum carpale is developed distally in *A. nipaloides* n. sp., not proximally. As in the humerus, these discrete characters are trends, which add to the body of identification criteria.

The femur of *Aquila nipaloides* n. sp. (Plate 1, figs 5–6), although showing the characteristics of the genus *Aquila*, is as long as *A. chrysaetos* or *A. nipalensis*, but much more slender than both, with very different proportions between the length of the bone and the width of the epiphyses. These appear smaller and narrower in *Aquila nipaloides* n. sp. In the proximal part of the bone, the facies articularis antitrochanterica is smaller and narrower in *Aquila nipaloides* n. sp. than in Palearctic living *Aquila* spp. The crista trochanteris is more elongated distally and less protruding, and the foramen pneumaticum of the cranial surface of the proximal part of the bone is larger and less rounded in *Aquila nipaloides* n. sp.

The tarsometatarsus of *Aquila nipaloides* n. sp. (Plate 1, fig. 8) is about the size of large *A. chrysaetos* or *A. nipalensis*. On the proximal part of the bone, the crista medialis hypotarsi is oriented slightly more proximally and is thinner in the new species than in Palearctic living *Aquila* spp. The crista plantaris mediana is robust in *A. nipaloides* n. sp. On the distal part of the bone, the fossa metatarsi I is distally close to the crista plantares medialis in the fossil species, not separated as in Palearctic living *Aquila* spp., in which the crista plantaris medialis is much less developed. The tarsometatarsi of *A. nipaloides* n. sp. are more slender on average than in *A. chrysaetos*, especially regarding the ratio distal width / length, but have similar proportions to those of *A. nipalensis* and *A. heliaca*, i.e. they are intermediate between *A. chrysaetos* and *Hieraaetus fasciatus*, the latter showing the most slender tarsometatarsi (Text-fig. 7, Appendix 2).

## Discussion

### 1. Systematic implications

Characteristics justifying the placement of the new species in the group *A. nipalensis-heliaca-adalberti*:

The mandibula shows all the characteristics of the *A. nipalensis-heliaca-adalberti* group and is much different from that of *A. chrysaetos* (see above section "Identification at the species level", Plate 2, and Appendix 2).

The humerus, ulna and tarsometatarsus of *A. nipaloides* n. sp. are relatively slender, as in the *A. nipalensis-heliaca-adalberti* group, and in contrast with those of *A. chrysaetos* (Text-figs 6, 7, Appendix 2).

The proportions of the pedal phalanxes 1I, 2I and 2II are the same as in *A. nipalensis*, *A. heliaca* and *A. adalberti*, i.e. more robust than in *A. chrysaetos*, including *A. c. bonifacti* MOURER-CHAUVIRÉ, 1975a, and even more than in *Hieraaetus fasciatus* for phalanx 1I (Text-figs 4, 5).

The pedal phalanxes are small relatively to the rest of the skeleton, as in *A. nipalensis*, *A. heliaca*, and *A. adalberti*, but unlike *A. chrysaetos* (Text-fig. 3).

*A. rapax* is not only far smaller than all of the above-cited species, but also has a different mandibula (see above section "Identification at the species level", and OLSON 1994). This species is therefore excluded from consideration here.

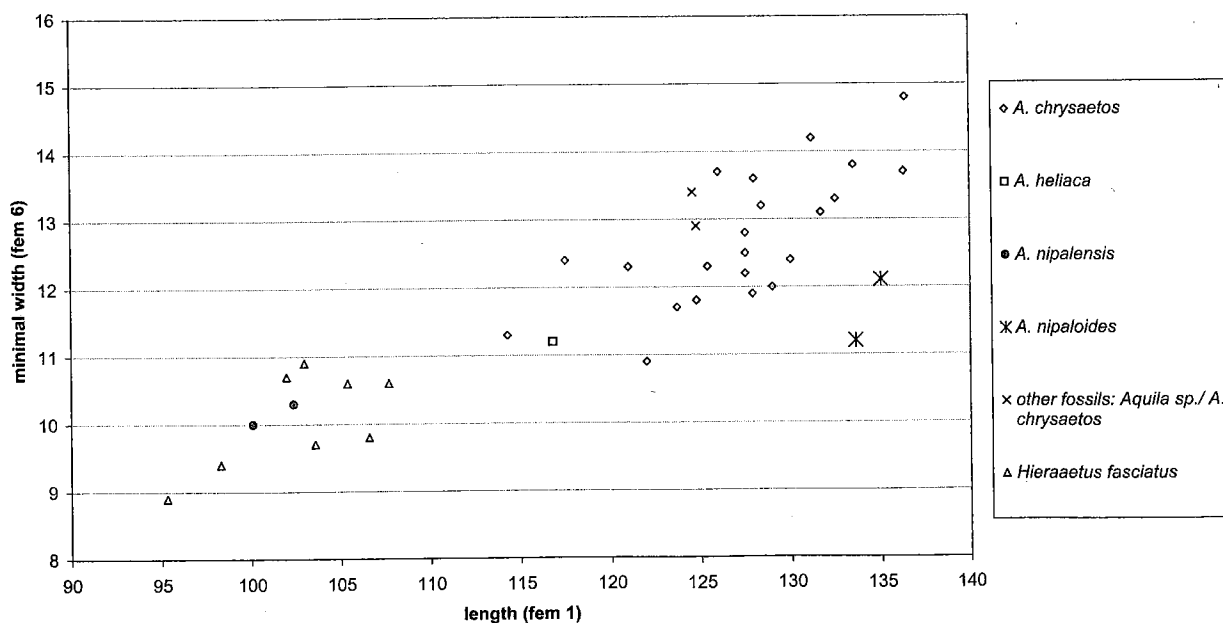

Text-Fig. 6. Scatter diagram showing the distribution of the femurs, according to their total length (1) and their minimal width (6), in the fossils and in different large living eagles.

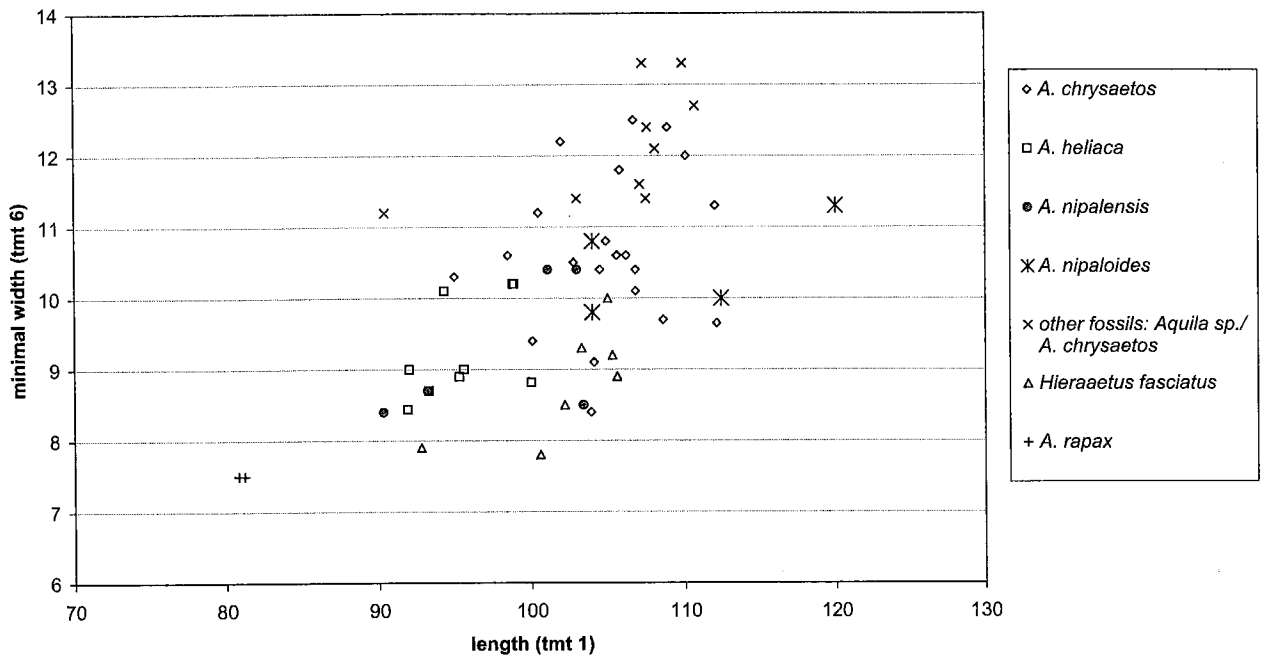

Text-Fig. 7. Scatter diagram showing the distribution of the tarsometatarsi, according to their total length (1) and their proximal height (6), in the fossils and in different large living eagles.

The hitherto subspecies *Aquila pomarina hastata* was recently given a specific status as *Aquila hastata* by PARRY et al. (2002). This was done based on characteristics of the plumage, external morphology, osteology, clutch size, and behavior. One particularly striking feature of *A. hastata* is the shape of its mandibula: bowed rami and reduced symphysis of *hastata* and relatively straight rami of *pomarina* (PARRY et al. 2002). The bowed rami are remarkably similar to the condition in *A. nipalensis*, thus we have to compare *A. hastata* to our fossils. The dimensions of the illustrated mandibula of *A. hastata* show that it is far smaller than that of both *A. nipalensis* and *A. nipaloides* n. sp. (see appendix 2), reaching on average only 75% of the values for the last two in all the measurements. Therefore *Aquila nipaloides* n. sp. is much closer to *A. nipalensis* than to *A. hastata* which shows also very small dimensions in postcranial bones (similar to *A. pomarina*; PARRY et al. 2002). In addition, the tarsometatarsus of *A. hastata* seems also proportionately more elongated than in *A. nipalensis* and *A. nipaloides* n. sp.

Characteristics showing proximity with *A. nipalensis*:

The mandibula shows the particular characteristics of *A. nipalensis*. The rami are more bowed than in *A. heliaca* and *A. adalberti*. The rami are also relatively long, and the pars symphyialis proportionately shorter than in *A. heliaca* and *A. adalberti*, but similar to that in *A. nipalensis* (Plate 2).

Differences from the most closely related extant forms:

The mandibula is slightly larger than in the largest available *A. nipalensis* (Appendix 2). The postcranial elements are generally slightly larger than in the extant *A. nipalensis* (Appendix 2, Text-figs 3, 4–7). The femur is more slender than in *A. nipalensis*, *A. heliaca*, and *A. adalberti* (Appendix 2, Text-fig. 6).

Compared with *A. nipalensis*, the tarsometatarsus of *A. nipaloides* n. sp. is larger without proportional change (Text-fig. 7). The maximal thickness of the tarsometatarsus diaphysis is relatively greater than in *A. nipalensis*, *A. heliaca*, and *A. adalberti*, which could be an allometric effect due to the weight-supporting role of the hindlimb. The assignment of the large tarsometatarsus from Cast3CG6 to the new species strengthens these characteristics, but if one removes the specimen from *A. nipaloides* n. sp., they still apply (Text-fig. 7).

The distal part of some sub-terminal pedal phalanxes and the proximal part of some claws, especially of the digits III and IV, are narrower than in *A. nipalensis*, *A. heliaca*, and *A. adalberti*. Some pedal phalanxes are larger than those of the largest individuals of *A. nipalensis*. Compared with *A. nipalensis*, the wing elements seem relatively more developed than the leg elements, based on the fossils available, but this difference is slight (Text-fig. 3).

#### Remarks about species limits:

Regardless of the species concept used, a species is diagnosable if at least one of these criteria applies (HELBIG et al. 2002):

- Individuals of at least one age/sex class possess one or more discrete characters that members of other species of the same class lack.
- Individuals of at least one age/sex class exhibit at least one complete discontinuity in a continuous character compared with otherwise similar taxa of the same class.
- Individuals of at least one age/sex class are well distinguished from individuals of the same class of all other taxa by a combination of two or three functionally independent characters.

The last two criteria would require a larger fossil sample than is available for *A. nipaloides* n. sp., and probably a larger recent sample too. The first criterion is met, however, based on the morphological and/or allometric differences observed in the femur, humerus, ulna, and tarsometatarsus. In addition, the dimensions of some elements (e.g. the mandibula, the pedal phalanxes) exceed those of the largest measured recent *A. nipalensis*. Finally, some elements have dimensions far exceeding those of *A. nipalensis*, *A. heliaca*, *A. adalberti*, and even *A. chrysaetos* (including the tarsometatarsus from Cast3CG6).

In paleontology, the difference between subspecies and species is not firmly established (STEWART 2002). We use the following criteria. A taxon is defined as a subspecies rather than a species if it lies within the variation of all of the recognized extant subspecies of the most closely related species. We demonstrated above that *A. nipalensis* is the species the closest to *A. nipaloides* n. sp. The former comprises two recognized subspecies: *A. nipalensis nipalensis* and *A. n. orientalis* (DEL HOYO et al. 1994). The characters observed on the tarsometatarsus and the femur of the new species are diagnostic when compared with both of the subspecies. These two extant subspecies are actually better not recognized (PARRY, pers. comm.). Therefore, even taking the insular context into account, and the lack of a possible sympatry between *A. nipalensis* and the fossil taxon, the specific status of the latter is required here.

#### Comparisons with extinct forms:

*Garganoaetus freudenthali* BALLMANN, 1973, from the Upper Miocene of the Gargano, at a first glance exhibits two similarities with *A. nipaloides* n. sp.: the length and slenderness of the tarsometatarsus, and the medio-lateral narrowness of the apophysis flexoris of the claws. However, *G. freudenthali*, classified by BALLMANN (1976) as being closer to the small eagles, differs from the genus *Aquila* in several characteristics which were included in the diagnosis of the genus *Garganoaetus* by BALLMANN (1973). With regards to *A. nipaloides* n. sp. the most significant concern the tarsometatarsus (see BALLMANN 1973). In *G. freudenthali*, the tuberositas tibialis does not extend dorsally from the planum cutaneum externum, the middle apophysis of the trochlea of digit II is developed farther, and the facies articularis metatarsalis I is imprinted deeper on the plantar surface. The trochlea of digit IV is larger and extends as far distally as the two other trochleae. The last character applies to *G. freudenthali* but not to the congeneric *G. murivorus* BALLMANN, 1973, which seems to be probably best referred to another genus (M. PAVIA, unpubl.). Consequently, the overall shape of the tarsometatarsus and the mediolateral narrowness of the apophysis flexoris of the claws, which are similar in *Garganoaetus freudenthali* and *Aquila nipaloides* n. sp., result from convergence and do not indicate any phylogenetic proximity.

The extinct subspecies from the Middle Pleistocene of St-Estève-Janson, *A. chrysaetos bonifaci* MOURER-CHAUVIRÉ, 1975a, is diagnosed by its dimensions, which are smaller than in living *A. chrysaetos*. These mainly are the: narrower coracoid, narrower radius diaphysis, narrower proximal femur, thinner distal tibiotarsus, and some lower measurement values for pedal phalanxes. Compared with this subspecies, *A. nipaloides* n. sp. can be distinguished by the following characteristics. Its pedal phalanxes are more robust (higher width/length ratios). Its posterior long bones are more slender. One may add all the other differences from *A. chrysaetos*, particularly in

the mandibula. Incidentally, it would be interesting to find some mandibulae of *A. chrysaetos bonifaci* to confirm its specific assignment.

*Buthierax pouliani* KRETZOI, 1977 (Middle Pleistocene, Petralona Cave, Western Chalkidiki, Greece) was at the time of the original publication neither illustrated nor was there an explicit detailed comparative description. Later, KRETZOI & POULIANOS (1981) provided two illustrations of the holotype, an almost complete left tarsometatarsus. Because the scale in the images is imprecise due to the way the photographs were taken, it is better to rely on the measurements provided by KRETZOI (1977), which are as follows: total length = 80,9 mm; proximal width = 15,7 mm; smallest width of the diaphysis = 7,4 mm; distal width = 15,9 mm. The photographs suggest decidedly greater values for all these measurements (e.g. total length = 90 mm). The only generic and specific features provided in the description are (KRETZOI 1977): "in proportions and in morphology it is bigger than the medium size accipitrid, between *Buteo rufinus* CRETZSCHMAR and *Hieraaetus fasciatus* VIEILLOT (...)". Whether any large or small morphology could ever be characterized remains hypothetical. The size and proportions, as well as the entire morphology, are actually perfectly similar to those of *Buteo rufinus jansoni* MOURER-CHAUVIRÉ, 1975b, in which the total length is relatively and absolutely lower than in living *B. rufinus*. *H. fasciatus* has a much larger and also more slender tarsometatarsus (LOUCHART 2001b, 2002). *B. r. jansoni* is known at St-Estève-Janson (Middle Pleistocene, Southern France; MOURER-CHAUVIRÉ 1975a, b), and *B. r. cf. jansoni* in the Middle Pleistocene of Castiglione 3 (Corsica; LOUCHART 2001b, 2002). Therefore we here synonymize *Buthierax pouliani* KRETZOI, 1977 with *Buteo rufinus jansoni* MOURER-CHAUVIRÉ, 1975b. The contemporaneity with other occurrences and the sharing of a Mediterranean location confirm the subspecies to have been a pre-Late Pleistocene Mediterranean endemic.

In the Pleistocene of Crete, WEESIE (1988) described a new extinct subspecies of *Aquila chrysaetos*, *A. c. simurgh*, endemic to Crete. By chance, with the object of making comparisons with *Aquila nipaloides* n. sp., we found that *A. c. simurgh* is clearly not an *Aquila* species, as far as we can judge from the plates. Among others, the holotype tibiotarsus illustrated by WEESIE (1988: pl. 5, fig. 3a, 3b) distally shows a morphology very different from that of the Accipitridae and even of all the Western Palearctic Falconiformes, and also other taxa like the Cathartidae, *Serpentarius sagittarius*, and *Theraptorius ecaudatus* (see e.g. JOLLIE 1977a, b, c). The distinctive character lies in the deep lateral pit, opposite to the retinaculum, but not joining the canalis musculi extensoris digitorum and the retinaculum, as it does in Falconidae. It thus is still different from that observed in *Falco* spp. The closest living forms seem to be *Polyborus*, *Milvago*, and *Herpetotheres*, all three of which are neotropical. These taxa bear a pit more reduced than in *Falco*, thus forming only a very narrow canal compared to the one in *Falco*. The large and distinctive two fossils of *Aquila chrysaetos simurgh* (a tibiotarsus – Li-V804, and a femur – Li-d801) are best left as Aves incertae sedis pending further investigations.

*Aquila borraasi* ARREDONDO, 1970 is a giant eagle from the Pleistocene of Cuba (ARREDONDO 1970, 1971, 1976). Its weight can be estimated as 14,4 kg, using the allometrical relations established for ecomorphological groups of birds by CAMPBELL & MARCUS (1992) and measurements from its very large femur (ARREDONDO 1976). The tarsometatarsus seems also very elongated, which would be a case of convergence with *Garganoaetus freudenthali*. Finally, the claws of this taxon are proportionately very developed, and are twice as large as those of *A. chrysaetos* (ARREDONDO 1976). This differentiates *A. borraasi* from *A. nipaloides* n. sp. The great geographic separation further excludes any close phylogenetic relationship between these two taxa. Moreover, the femur of *A. borraasi* looks different from the Corso-Sardinian fossils, and from extant *Aquila* species. This was already noted by OLSON & HILGARTNER (1982), who thought that the taxon is probably referable to the genus *Titanohierax* from the Bahamas.

EMSLIE & CZAPLEWSKI (1999) described two eagle species from the Upper Pliocene of Florida and Arizona. One is *Amplibuteo concordatus*, the other being *Aquila bivia*. *Amplibuteo* differs from *Aquila* in several features of the carpometacarpus and the humerus, the latter being well distinct from *A. nipaloides* n. sp. Therefore only *Aquila bivia* remains to be compared to *A. nipaloides* n. sp. The size of *A. bivia* is similar to the largest individuals of *A. chrysaetos*. The most useful element to be compared is the paratype femur of *A. bivia*. It shows none of the characteristics of *A. nipaloides* n. sp., including the thin and narrow proximal femur, as well as the general slenderness of the whole element, in the latter. The ratio of least width of diaphysis to total length is greater in *A. bivia*. The same is true for the ratio of distal width to total length. Finally, geographical separation also serves to exclude *A. bivia* from consideration for the assignment of our fossils.

HOWARD (1935) described a new species of eagle from the Pleistocene of Nevada, *Spizaetus willetti* HOWARD,



1935. This is a very large eagle, the distal width of the tarsometatarsus being 28,5 mm, which is as large as the largest individuals of *A. chrysaetos*. A distal tarsometatarsus is the only specimen for which details are given. Actually, this bone shows similarities with *A. nipaloides* n. sp. Our study revealed that *S. willetti* shows similarities with *Aquila*, which was acknowledged by HOWARD (1935). She concluded that "the balance is in favor of" *Spizaetus*, but the characters seem weak, and the generic assignment probably deserves the study of more material. Moreover, as *Spizaetus* is close to *Hieraaetus*, its relationship with *Aquila* should probably also be reevaluated. The genus *Spizaetus* is used by HOWARD (1935) in a wide sense, including *Polemaetus bellicosus*. This species is actually thought by her to be morphologically closest to the Nevadan fossil. This seems to contradict our observations about *Polemaetus* (see above). The uncertainty of the identification of *S. willetti*, along with its great geographical separation, led us to exclude it from consideration in identifying of the Corso-Sardinian remains.

Some complete mandibulae of a large eagle are known from Rancho la Brea (Upper Pleistocene, California, USA). They show differences from *A. chrysaetos*, the only living large eagle of the area. Of particular interest are their bowed rami (HOWARD 1947). However the author considered the sample too small for further identification (HOWARD 1947). The Californian fossils may represent a species close to the palearctic group of *A. nipalensis-beliaca-adalberti*. The measurements given seem quite distinctive from recent *A. chrysaetos* samples; HOWARD (1947) even notes that there is no overlap with the Golden Eagle in the measurement of cranium height relative to width across the postorbital processes, as well as in the measurement of width across the rami of the mandibula. This Rancho la Brea eagle needs to be reevaluated, but this has no direct bearing on our study. The material suggests, however, a much wider past distribution of *A. nipalensis*-like eagles in the Pleistocene than today.

Two still unidentified species of *Aquila* have been reported from the Upper Pleistocene of Madagascar (GOODMAN & RAKOTOZAFY 1994) based on two complete tarsometatarsi. The larger one is very similar in size and proportions to *Aquila chrysaetos*, while the smaller is from a small eagle, and is even shorter and stouter than in *Aquila rapax*. These observations argue against a relationship between these forms and *A. nipaloides* n. sp.

## 2. Evolution and endemism

At a first glance, it seems unlikely for an endemic species of large eagle to have evolved independently in the limited area of a Mediterranean island. One could object that today some eagles are migrating through these islands from Europe to Africa, and that this would have prevented the evolution of an endemic insular species. Second, the area of the island could seem too small for an isolated population of large eagle to survive in the long run.

It is true that in the Pleistocene the continental European Steppe Eagles *Aquila nipalensis* were certainly migratory like today and that some migrated through Corsica-Sardinia. This species is seen by us as the parent species for the new *A. nipaloides*. We argue that a population of this eagle could well have become partly isolated genetically on the Pleistocene Corsica-Sardinia island. There only needs to have been reduced, not necessarily completely suppressed, interbreeding with continental individuals. In this case, the insular, southern individuals became sedentary, while the continental individuals remained migratory and only passed through the island during migration. The recent isolation of the Spanish Eagle *A. adalberti*, which is very close to the Imperial Eagle *A. heliaca*, is very likely an example of such a process. Today *A. adalberti* is sedentary, and *A. heliaca* is migratory (DEL HOYO et al. 1994). At the beginning of their differentiation, this difference in habits certainly played a role in the specific isolation, together with a partial geographical separation. The latter grew in time with the retreat of *A. heliaca* from western Europe as late as during the Holocene – probably for environmental reasons. We therefore propose that a sedentary population of *A. nipalensis* initially became established on the island. This population evolved gradually more independently from the continental stock, individuals of which only passed through the island during fall or spring. By the same process, many insular subspecies of birds, sometimes regarded as full species, arose on Mediterranean islands from migratory continental species that still pass through during fall or spring. Examples are the shrike *Lanius (senator) badius* in Corsica, which became isolated from the migratory continental *L. senator senator*. In this case, both subspecies are still migratory, wintering in Africa (THIBAUT & BONACCORSI 1999). Other examples at the specific level are the wheatear *Oenanthe cyprica* and the warbler *Sylvia melanothorax*. Both are migratory but breed only on Cyprus, and are isolated from their also migratory respective parent species (CRAMP & SIMMONS 1998). In these cases, slight differences in breeding periods between

the insular and the continental individuals both frequenting the same island were sufficient to isolate them from each other. There are many other cases at the subspecies level, which are likely to lead to speciation in due course. We conclude that a migratory habit of a species alone does not preclude isolation of a population on an island.

The second point of discussion concerns the risk of extinction of a population of limited size. Actually, extinction is what finally happened to the new species, and we can hypothesize that a drastic areal reduction of the island(s) in the Holocene is part of the explanation. However, during most of the Pleistocene, the area of the island was around 40-45000 km<sup>2</sup> (LOUCHART 2002). The population density of breeding *A. nipalensis* today is between 1 pair/7,5 km<sup>2</sup> to 1 pair/53,5 km<sup>2</sup> (DEL HOYO et al. 1994). If we extrapolate these values, there may have been a total of 840 to 6000 pairs of *A. nipaloides* simultaneously on the island, during the Pleistocene. An estimate closer to 6000 is more reasonable because we can hypothesize that the island offered a favorable habitat. Moreover, population densities on islands are typically higher than on a continent (e.g. GRANT 1998). An estimate of several thousand pairs thus seems reasonable, and this is apparently sufficient for a healthy population. The current population of the Lammergeier *Gypaetus barbatus* in Corsica is 8 pairs. It has survived at a similar size for several centuries, and the population is actually the healthiest one in Western Europe (THIBAUT & BONACCORSI 1999). The number of Black Vultures *Aegypius monachus* on the island of Mallorca, Spain, is today around 80 pairs (P. BOVER, pers. comm.). It is one of the healthiest populations of the species. The endemic insular Javan Hawk-Eagle *Spizaetus bartelsi* numbers less than 100 pairs today, but it is “only” considered ‘vulnerable’ and not (yet ?) ‘endangered’ (DEL HOYO et al. 1994). Another example is the harrier *Circus maillardi*, a species endemic to Réunion island, which was also present before the arrival of humans on Mauritius island (BLANCHARD 2000, BRETAGNOLLE et al. 2000, MOURER-CHAUVIRÉ et al. 2004). This is the harrier species with the smallest range in the world. Even in the Pleistocene, the total area of Réunion and Mauritius did not exceed 4500 km<sup>2</sup>, a tenth of the Corsica-Sardinia island. *Circus maillardi* is smaller than *Aquila nipalensis* or *A. nipaloides*, approximately an eighth to a tenth of their weight. Thus there is the same ratio of body size to island area. Size being correlated with population density, and therefore insular population size, the area of Corsica-Sardinia is likely to have been sufficient to support the large eagles.

Another case in point are the Gargano “island(s)” which had many endemic birds, including the eagle *Garganoaetus freudenthali*, similar in size to the new species. The Gargano island may have been of comparable area to the Corsica-Sardinia island. Also of comparable size was the Pleistocene island of Cuba. Many endemic raptors lived there, including the very large – actually gigantic – owl *Ornimegalonyx oteroi* (1 meter tall) and the very large eagle “*Aquila*” *borrasi* (see above); this eagle was much larger than our species (see e.g. LOUCHART 2001b, 2002).

Corsica and Sardinia were also inhabited by the endemic owl *Bubo insularis*. Its average weight can be estimated at around 1 kg, while the new eagle weighed around 3–3,5 kg (LOUCHART 2002). The owl, which was probably very sedentary, survived well into the Holocene on both islands. The weight of the new eagle being only three times that of the owl argues for the possibility of a healthy population on this large Pleistocene island.

All this indicates that the population of an endemic *A. nipaloides* would certainly have been viable on the Corsica-Sardinia island during the Pleistocene.

Since *Aquila nipaloides* n. sp. probably evolved from *A. nipalensis*, an increase in body size likely occurred through the insular evolutionary process. The record of insular birds of prey suggests that in several cases such an increase is an adaptation to the size of some large endemic insular preys (e.g. LOUCHART 2001b). The prey of *A. nipaloides* n. sp. could have been different and larger than that of *A. nipalensis* on the continent. *A. nipaloides* may have fed on *Prolagus sardus* and probably juvenile *Megaceros (Nesoleipoceros) cazioti*.

*Aquila nipaloides* n. sp. represents the first Pleistocene insular endemic form of Falconiformes in the Mediterranean (see MOURER-CHAUVIRÉ et al. 2001). Insular endemic Strigiformes, on the other hand, are well represented in the Pleistocene of some Mediterranean islands (MOURER-CHAUVIRÉ et al. 1986, 1997, PAVIA 1999, PAVIA & MOURER-CHAUVIRÉ 2002, WEESIE 1982). There are only two other Mediterranean endemic, but not strictly insular, Falconiformes in the Pleistocene: *Gyps melitensis* and *Buteo rufinus jansoni*. The Mediterranean insular endemism in living Strigiformes and Falconiformes seems greatly reduced compared with the Pleistocene. There remains only some subspecies, which are osteologically less differentiated from non-endemics than are extinct Pleistocene taxa (LOUCHART 2001b, 2002).

### 3. Paleobiogeography and paleoecology

Some remains of *A. nipaloides* n. sp. were initially identified as *Hieraaetus fasciatus* because of the size and proportions of the tarsometatarsi (MOURER-CHAUVIRÉ in THIBAUT & BONACCORSI 1999), but the present study does not support the occurrence of *Hieraaetus fasciatus* in the Pleistocene of at least Corsica and Sardinia. Today the species lives in Sardinia but is only a straggler to Corsica (THIBAUT 1983, THIBAUT & BONACCORSI 1999). It seems that it arrived on these islands during the Holocene.

In the Late Pleistocene of Corsica and Sardinia, two large species of *Aquila* were living contemporaneously: *Aquila nipaloides* n. sp. and *A. chrysaetos*. The coexistence of these two species probably was possible due to limited competition for food. *Aquila nipalensis*, the probable ancestor of *A. nipaloides* n. sp., is a widespread species living in the steppe or other open environments, while *A. chrysaetos* prefers rocky and more closed environments. In addition, the Late Pleistocene vertebrate fauna of Corsica and Sardinia was very rich and diverse and thus by itself probably able to support two sympatric species of large *Aquila*. Today, two large eagles (*A. chrysaetos* and *H. fasciatus*) coexist only in Sardinia, which could be related to richer habitats and to the larger area of Sardinia. From this point of view, the large area covered by the Corsosardinian "microcontinent" (five times the present area of Corsica; LOUCHART 2001b) probably allowed a richer avifauna in general, following the global species - area relation.

The presence in Corsica and Sardinia of the new endemic form closely related to *Aquila nipalensis* suggests that the latter lived on the adjacent continent in the widespread steppe-tundra, along with other still living steppe species (TYRBERG 1991, LOUCHART 2001a). In Corsica and Sardinia, paleoecological evidence from sites with *A. nipaloides* n. sp., mainly consisting of the fossil birds from the Coscia and Castiglione sites, also indicate the prevalence of a steppe-like environment, in contrast with the present and most of the Holocene, which is characterized largely by a 'maquis'-type wooded or bushy environment (LOUCHART 2001b, 2002 and references cited).

Another issue to be discussed is the Quaternary biogeography of large Holarctic eagles. The scarcity of material, notably cranial remains, still makes the identification of fossil eagles very difficult. Some material from St-Estève-Janson (Middle Pleistocene, continental France) attributed to a large *A. clanga* (MOURER-CHAUVIRÉ 1975a) fit much better with *A. nipalensis*. This St-Estève eagle is too large to belong to *A. clanga*, especially considering the phalanges. At that time, *A. nipalensis* was considered a subspecies of *A. rapax*, which led MOURER-CHAUVIRÉ (1975a) to use for comparisons, as specimens of both recent *A. rapax* and *A. nipalensis*, recent specimens today assigned to *A. rapax*, because they are much more common in western collections than specimens of *A. nipalensis*. *A. rapax* being different in proportions and much smaller than *A. nipalensis*, this explains why it is now necessary to use the latter species for comparisons, in order to re-evaluate such records.

The problem of confusion of *A. nipalensis* with *A. rapax* is still a source of errors, mainly when using old collections for comparisons. Recent crania of *A. nipalensis* from south Asia in the British Museum collection were originally labeled as *A. chrysaetos* because of their large size and insufficient knowledge of eastern *A. nipalensis*, but corrections have now been made (by S.J. PARRY). Some specimens from the Laboratoire d'Anatomie Comparée (Paris) still labeled as *A. rapax*, but clearly belonging to *A. nipalensis*, are listed here as such (Appendix 1).

Today, the living *Aquila nipalensis* is the most abundant large eagle in the world, and is associated with steppe environments (DEL HOYO et al. 1994). *A. nipalensis* must be taken into account when identifying eagle fossils of Pleistocene age from Western Palearctic, contrary to what has been done previously. There are no historical confirmed records of regular occurrence of *A. heliaca* or *A. adalberti* in Corsica or Sardinia, and absolutely none of *A. nipalensis* or *A. rapax* (CRAMP & SIMMONS 1998, THIBAUT 1983, THIBAUT & BONACCORSI 1999). This makes *A. nipaloides* n. sp. most interesting because it indicates that most probably *A. nipalensis* turned up in these islands regularly at some point during the Pleistocene or earlier. *A. nipalensis* or its direct ancestor was certainly present and widespread in Europe during the Pleistocene, whereas today the westernmost populations live in southern Ukraine (CRAMP & SIMMONS 1998).

*A. nipalensis* and *A. hastata* both have large gapes. PARRY et al. (2002) suggest two possible explanations, which need data in support: greater hyperventilation ("especially when confined to the nest"), and larger size of preys. Thus, there is a need to study temperature conditions and available prey size in each of the species listed above. However, it seems likely from the topology proposed by SEIBOLD (1994) that a large gape is the primitive condition of the *nipalensis-rapax-heliaca-adalberti* clade as well as inside the *hastata-pomarina-clanga* clade.

## Conclusions

*Aquila nipaloides* n. sp. is described from fossils of different karst, fissure, and cave localities of Corsica and Sardinia. The fossil assemblages from these localities have been dated or attributed to the Late Pleistocene. A single exception is a Middle Pleistocene find from Castiglione (Corsica). *Aquila nipaloides* n. sp. is large and similar in size to the extant *Aquila chrysaetos*, from which it can be separated by several morphological and morphometrical features of the mandibula, some long bones, and pedal phalanges. The morphology of the mandibula and the proportions of the long bones show a close relationship between the fossil species and the extant *Aquila nipalensis*, treated here as its very likely ancestor. Several apomorphic characters allow separation of the new species from *A. nipalensis*. The analysis of fossil bones from the various Corsican and Sardinian localities also indicates the coexistence of the new species and *A. chrysaetos*, at least during the Middle and Late Pleistocene. This fact indicates the presence on the islands of a different kind of environment, with extensive steppe-like vegetation and associated prey, indicated by *Aquila nipaloides* n. sp., together with more rocky and wooded habitats, indicated by *A. chrysaetos*. The rest of the avifauna from the sites clearly show that this steppe environment was widespread (LOUCHART 2001a, 2001b, 2002).

The presence of a descendant of *Aquila nipalensis* in the Late Pleistocene of Corsica and Sardinia also suggests a widespread distribution of this species in Europe during the Pleistocene, living in the steppe-tundra environment together with other bird species (TYRBERG 1991). The former presence of *A. nipalensis* in Europe has probably been underestimated due to the difficulty in separating its postcranial elements from the other *Aquila* species and its present eastern distribution, with breeding grounds in easternmost Europe s.l. and Asia.

The new species represents the first positive evidence of fossil eagles clearly belonging to the *A. nipalensis-rapax-heliaca-adalberti* clade, and especially close to *A. nipalensis*. There is a strong need for the revision of eagles from many paleontological (mainly Quaternary) sites. We need to take into account taxa with currently far easterly ranges, like *A. nipalensis*, especially in Pleistocene steppe-tundra environments. We also show that there was endemism, hitherto unrecognized, in large eagles in the region until the Late Pleistocene, somewhat concomitant with mammalian endemism.

Finally we propose here to synonymize *Buthierax pouliani* KRETZOI, 1977 from the Middle Pleistocene of Greece with *Buteo rufinus jansonii* MOURER-CHAUVIRÉ, 1975b. We also emphasize that the morphology of *Aquila chrysaetos simurgh* WEESIE, 1988 from the Pleistocene of Crete is very different from all *Aquila* species, and we propose here to leave it as *Aves incertae sedis* pending further investigations.

## Acknowledgements

The authors are indebted to R. Manni, curator of the Museo di Paleontologia, Università “La Sapienza” of Roma, for the loan of the Dragonara material. The authors also would like to thank P. Sondaar (Utrecht, for the loan of the material from Corbeddu and Rapaci Cave, as well as Michelle Salotti, and Eugène and Marie-Françoise Bonifay for making available the material from Castiglione and Coscia respectively. We thank Robert Prys-Jones, Christine Lefèvre, Marylène Patou-Mathis, and Giovanni Boano for the access to the collections of the NHM (Tring), the Anatomie Comparée and IPH collections of the MNHN (Paris), and the collections of MCCI (Carmagnola). We also thank Erika Gal for data from the Hungarian Museum of Natural History (Budapest). We are grateful to Cécile Mourer-Chauviré for data about *Polemaetus*, access to the collection of UCBL (Villeurbanne), and advice on the manuscript. We are grateful to Dr. M. Sander (Bonn) for his comments and linguistic improvements on the manuscript. At last, we are indebted to S.J. Parry (Natural History Museum and University College London) for much useful information and comments about eagle osteology, particularly about *Aquila nipalensis*. Many thanks go to Dr. Ursula Goehlich (Munich) for corrections to the German abstract.

## References

- ALCOVER, J.A., FLORIT, F., MOURER-CHAUVIRÉ, C. & WEESIE, P.D.M. (1992): The avifaunas of the isolated mediterranean islands during the middle and late Pleistocene. – In: CAMPBELL, K.E. (Ed.): Papers in Avian Paleontology honoring Pierce Brodkorb, incorporating the Proceedings of the II International Symposium of the Society of Avian Paleontology and Evolution, Natur. Hist. Mus. of Los Angeles County, 1988. – Sci. Ser., Natur. Hist. Mus. Los Angeles County, 36: 273–283.
- ARREDONDO, O. (1970): Nueva especie de Ave Pleistocénica del orden Accipitriformes (Accipitridae) y nuevo género para las Antillas. – Ciencias, 4(8): 1–19.
- (1971): El águila cubana de la prehistoria. – Bohemia, 63(6): 94–97.
- (1976): The great predatory birds of the Pleistocene of Cuba. In: – OLSON, S.L. (Ed.): Collected Papers in avian paleontology honoring the 90th birthday of ALEXANDER WETMORE. – Smithsonian Contrib. Paleobiol., 27: 169–187.

- BALLMANN, P. (1973): Fossile Vögel aus dem Neogen der Halbinsel Gargano (Italien). – *Scr. Geol.*, **17**: 75 pp.
- (1976): Fossile Vögel aus dem Neogen der Halbinsel Gargano (Italien), zweiter Teil. – *Scr. Geol.*, **38**: 59 pp.
- BAUMEL, J.J. & WITMER, L.M. (1993): 4. Osteologia. – In: BAUMEL, J.J. (Ed.): *Handbook of avian anatomy: Nomina Anatomica Avium*, 2<sup>nd</sup> Ed., – Nuttall Ornithological Club, Cambridge, Massachusetts, publ. 23, 637 pp.: 45–132.
- BEAMAN, M. & MADGE, S. (1998): *Guide encyclopédique des oiseaux du Paléarctique occidental*. – (Nathan) Paris, 872 pp.
- BLANCHARD, F. (2000): *Guide des milieux naturels – La Réunion, Maurice, Rodrigues*. – (Ulmer) Paris, 384 pp.
- BONIFAY, E., BASSIAKOS, Y., BONIFAY, M.F., LOUCHART, A., MOURER-CHAUVIRÉ, C., PEREIRA, E., QUINIF, Y. & SALOTTI, M. (1998): La grotte de la Coscia (Rogliano, Macinaggio): étude préliminaire d'un nouveau site du Pléistocène supérieur de Corse. – *Paléo*, **10**: 17–41.
- BRETAGNOLLE, V., THIOLLAY, J.M. & ATTIE, C. (2000): Status of Réunion Marsh Harrier *Circus maillardi* on Réunion Island. – In: CHANCELLOR, R.D. & MEYBURG, B.U. (Eds.): *Raptors at risk*. – (WWGBP/Hancock House) London: 669–676.
- CAMPBELL, K.E. JR & MARCUS, L. (1992): The relationship of hindlimb bone dimensions to body weight in birds. – In: CAMPBELL, K.E. (Ed.): *Papers in Avian Paleontology honoring PIERCE BRODKORB, incorporating the Proceedings of the II International Symposium of the Society of Avian Paleontology and Evolution*, *Natur. Hist. Mus. of Los Angeles County*, 1988. – *Sci. Ser., Natur. Hist. Mus. Los Angeles County*, **36**: 395–412.
- CLARK, W.S. (1992): The taxonomy of Steppe and Tawny Eagles, with criteria for separation of museum specimens and live eagles. – *Bull. B.O.C.*, **112**: 150–157.
- CRAMP, S. & SIMMONS, K.E.L. (1998): *The complete birds of the Western Palearctic on CD-Rom*. – (Oxford University Press CD-Rom) Oxford.
- DEL HOYO, J., ELLIOTT, A. & SARGATAL, J. (1994): *New World vultures to guineafowl. Handbook of the Birds of the World, vol. 2*. – (Lynx Edicions) Barcelone, 638 pp.
- DIAMOND, J. (1991): A new species of rail from the Solomon Islands and convergent evolution of insular flightlessness. – *The Auk*, **108**(3): 461–470.
- EMSLIE, S.D. & CZAPLEWSKI, N.J. (1999): Two new fossil eagles from the Late Pliocene (Late Blancan) of Florida and Arizona and their biogeographic implications. – In: OLSON, S.L., WELLNHOFER, P., MOURER-CHAUVIRÉ, C., STEADMAN, D.W. & MARTIN, L.D. (Eds.): *Avian Paleontology at the close of the 20th century: Proceedings of the 4th International Meeting of the Society of Avian Paleontology and Evolution*, 1996. – *Smithson. Contrib. Paleobiol.*, **89**: 185–198.
- GÉROUDET, P. (1965–1984): *Les rapaces diurnes et nocturnes d'Europe*. – (Delachaux & Niestlé) Lausanne, 426 pp.
- GOODMAN, S.M. & RAKOTZAFY, L.M.A. (1995): Evidence for the existence of two species of *Aquila* on Madagascar during the Quaternary. – *Geobios*, **28**(2): 241–246.
- GRANT, P.R. (1965): The adaptive significance of some size trends in island birds. – *Evolution*, **19**: 355–367.
- (1998): *Evolution on islands*. – (Oxford University Press) Oxford, 334 pp.
- HELBIG, A.J., KNOX, A.G., PARKIN, D.T., SANGSTER, G. & COLLINSON, M. (2002): Guidelines for assigning species rank. – *Ibis*, **144**: 518–525.
- HOWARD, H. (1935): A new species of eagle from a quaternary cave deposit in eastern Nevada. – *The Condor*, **37**: 206–209.
- (1947): An ancestral golden eagle raises a question in taxonomy. – *The Auk*, **64**: 287–291.
- JOLLIE, M. (1977a): A contribution to the morphology and phylogeny of the Falconiformes. I. – *Evolut. Theor.*, **2**(3): 20–114.
- (1977b): A contribution to the morphology and phylogeny of the Falconiformes. II. – *Evolut. Theor.*, **2**(4): 115–208.
- (1977c): A contribution to the morphology and phylogeny of the Falconiformes. III. – *Evolut. Theor.*, **2**(5): 209–300.
- JONSSON, L. (1992): *Birds of Europe with North Africa and the Middle East*. – (Christopher Helm Ltd) London, 559 pp.
- KRETZOI, M. (1977): The fauna of small vertebrates of the Middle Pleistocene at Petralona. – *Anthropos*, **4**(1/2): 131–143.
- KRETZOI, M. & POULIANOS, N.A. (1981): Remarks on the Middle and Lower Pleistocene vertebrate fauna in the Petralona Cave (with special reference to new Microfauna – up to 1981). – *Anthropos*, **8**: 57–72.
- LIVEZEY, B.C. (1990): Evolutionary morphology of flightlessness in the Auckland Islands teal. – *The Condor*, **92**(3): 639–673.
- LOUCHART, A. (2001a): Aspects de la biogéographie des oiseaux de Corse à la limite Pléistocène supérieur – Holocène dans le contexte européen. – *Alauda*, **69** (3): 345–354.
- (2001b): Oiseaux insulaires – Le cas du Pléistocène de Corse et son contexte, écologie, évolution, biogéographie et extinctions. – Ph.D. dissertation, Université Claude Bernard – Lyon 1, Villeurbanne, France, 530 pp.
- (2001c): Les oiseaux du Pléistocène de Corse et données concernant la Sardaigne. – *Bull. Soc. Sci. hist. nat. Corse*, **696-697**: 187–221.
- (2002): Les oiseaux du Pléistocène de Corse, et de quelques localités sardes – écologie, évolution, biogéographie et extinctions. – *Docum. Lab. Géol. Lyon*, **155**: 287 pp., 37 fig., 206 tab., 9 pl.
- MALATESTA, A. (1970): *Cynotherium sardous* Studiatii, an extinct canid from the Pleistocene of Sardinia. – *Mem. Ist. Paleontol. Umana*, **N.S.** **1**: 1–72.
- MALATESTA, A. & SURIANO, F. (1970): Avifauna pleistocenica di Alghero (Sardegna). – *Boll. Serv. Geol. d'Italia*, **91**: 149–158.
- MOURER-CHAUVIRÉ, C. (1975a): Les oiseaux du Pléistocène moyen et supérieur de France. – *Docum. Lab. Géol. Fac. Sci. Lyon*, **64** (1/2): 624 pp.
- (1975b): Un exemple d'évolution chez les oiseaux au Quaternaire: *Buteo rufinus jansoni* nov. subsp. (Aves, Falconida, Accipitridae) du Pléistocène moyen de Saint-Estève-Janson (Bouches-du-Rhône, France). – In: *Colloque international C.N.R.S. n° 218: Problèmes actuels de paléontologie – évolution des vertébrés*, 1973, Paris: 533–542.
- MOURER-CHAUVIRÉ, C., BOUR, R., MOUTOU, F. & RIBES, S. (1994): *Mascarenotus* nov. gen. (Aves, Strigiformes), genre endémique éteint des Mascareignes et *M. grucheti* n. sp., espèce éteinte de La Réunion. – *C.R. Acad. Sci. Paris, (II)* **318**: 1699–1706.

- MOURER-CHAUVIRÉ, C., BOUR, R. & RIBES, S. (2004): The taxonomic identity of *Circus alphonsi* (Newton & Gadow 1893), the extinct harrier from Mauritius. – *Ibis*, **146**: 168–172.
- MOURER-CHAUVIRÉ, C., LOUCHART, A., PAVIA, M. & SEGUI, B. (2001): Les avifaunes du Pléistocène moyen et supérieur des îles méditerranéennes. – *Bull. Soc. Sci. hist. nat. Corse*, 696-697: 223–244.
- MOURER-CHAUVIRÉ, C., SALOTTI, M., PEREIRA, E., QUINIF, Y., COURTOIS, J.Y., DUBOIS, J.N. & LA MILZA, J.C. (1997): *Athene angelis* n. sp. (Aves, Strigiformes), nouvelle espèce endémique insulaire éteinte du Pléistocène moyen et supérieur de Corse (France). – *C.R. Acad. Sci. Paris, (II)* **324**: 677–684.
- MOURER-CHAUVIRÉ, C. & WEESIE, P.D.M. (1986): *Bubo insularis* n. sp., forme endémique insulaire de grand-duc (Aves, Strigiformes) du Pléistocène de Sardaigne et de Corse. – *Revue Paléobiol.*, **5**: 197–205.
- OLSON, S.L. (1983): Flightless birds. – *Nat. Hist.*, **92**(9): 30–40.
- ,– (1994): Cranial osteology of tawny and steppe eagles *A. rapax* and *A. nipalensis*. – *Bull. B.O.C.*, **114**(4): 264–267.
- OLSON, S.L. & HILGARTNER, W.B. (1982): Fossil and subfossil birds from the Bahamas. – In: OLSON, S.L. (Ed.): *Fossil Vertebrates from the Bahamas*. – *Smithson. Contr. Paleobiol.*, **48**: 22–56.
- OLSON, S.L. & JAMES, H.F. (1991): Description of thirty-two new species of birds from the Hawaiian Islands: Part I. Non-Passeriformes. – *Ornitholog. Monogr.*, **45**: 3–88.
- PARRY, S.J., CLARK, W.S. & PRAKASH, V. (2002): On the taxonomic status of the Indian Spotted Eagle *Aquila hastata*. – *Ibis*, **144**: 665–675.
- PAVIA, M. (1999): The Middle Pleistocene avifauna of Spinagallo Cave (Sicily, Italy): Preliminary report. – In: OLSON, S.L., WELLNHOFER, P., MOURER-CHAUVIRÉ, C., STEADMAN, D.W. & MARTIN, L.D. (Eds.): *Avian Paleontology at the close of the 20th century: Proceedings of the 4th International Meeting of the Society of Avian Paleontology and Evolution, 1996*. – *Smiths. Contr. Paleobiol.*, **89**: 125–127.
- PAVIA, M. & MOURER-CHAUVIRÉ, C. (2002): An overview of the genus *Athene* in the Pleistocene of the Mediterranean Islands, with the description of *Athene trinacriae* n. sp. (Aves: Strigidae). – In: ZHOU, Z. & ZHANG, F. (Eds.): *Proceedings of the 5<sup>th</sup> Symposium of the Society of Avian Paleontology and Evolution, Beijing (China), 1-4 June 2000*. – (Science Press) Beijing: 13–27.
- PEREIRA, E. (2001a): Le peuplement mammalien quaternaire de Corse (Post-Glaciaire exclu), son contexte environnemental, biologique et physique. – Ph.D. dissertation, Université Pascal Paoli de Corse, France: 340 pp.
- ,– (2001b): *Cervus elaphus rossii* (Mammalia, Artiodactyla), a new endemic sub-species from the Middle Pleistocene in Corsica. – *Palaeovertebrata*, **30**: 189–213.
- PEREIRA, E., ROUZAUD, F., SALOTTI, M., DUBOIS, J.N., FERRANDINI, J., OTTAVIANI-SPELLA, M.M. & QUINIF, Y. (1999): Castiglione (Oletta, Corsica): relationships between phenomena of calcification and tectonic fossiliferous fracture dating. – *Geodinamica Acta*, **12**: 371–375.
- SALOTTI, M., BAILON, S., BONIFAY, M.F., COURTOIS, J.Y., DUBOIS, J.N., FERRANDINI, J., LA-MILZA, J.C., MOURER-CHAUVIRÉ, C., POPELARD, J.B., QUINIF, Y., RÉAL-TESTUD, A.M., MINICONI, C., PEREIRA, E. & PERSIANI, C. (1997): Castiglione 3, un nouveau remplissage fossilifère d'âge Pléistocène moyen dans le karst de la région d'Oletta (Haute-Corse). – *C.R. Acad. Sci. Paris, (IIa)* **324**: 67–74.
- SALOTTI, M., BELLOT-GOURLET, L., COURTOIS, J.Y., DUBOIS, J.N., LOUCHART, A., MOURER-CHAUVIRÉ, C., OBERLIN, C., PEREIRA, E., POUPEAU, G. & TRAMONI, P. (2000): La fin du Pléistocène supérieur et le début de l'Holocène en Corse: apports paléontologique et archéologique du site de Castiglione (Oletta, Haute-Corse). – *Quaternaire*, **11**(3/4): 219–230.
- SANGSTER, G., KNOX, A.G., HELBIG, A.J. & PARKIN, D.T. (2002): Taxonomic recommendations for European birds. – *Ibis*, **144**(1): 153–159.
- SEIBOLD, I. (1994): Untersuchungen zur molekularen Phylogenie der Greifvögel anhand von DNA-Sequenzen mitochondriellen Cytochrom-b-gens. – (Hartung-Gorre Verlag) Konstanz, 228 pp.
- STEWART, J.R. (2002): The evidence for the timing of speciation of modern continental birds and the taxonomic ambiguity of the Quaternary fossil record. – In: ZHOU, Z. & ZHANG, F. (Eds.): *Proceedings of the 5<sup>th</sup> Symposium of the Society of Avian Paleontology and Evolution, Beijing (China), 1-4 June 2000*. – (Science Press) Beijing: 259–280.
- SUAREZ, W. & OLSON, S.L. (2001): A remarkable new species of small falcon from the Quaternary of Cuba (Aves: Falconidae: *Falco*). – *Proc. Biol. Soc. Washington*, **114**(1): 34–41.
- THIBAUT, J.C. (1983): Les oiseaux de la Corse, histoire et répartition aux XIX<sup>e</sup> et XX<sup>e</sup> siècles. – Eds. Parc Naturel Régional de la Corse. (Gerfau Impression) Paris, 255 pp.
- THIBAUT, J.C. & BONACCORSI, G. (1999): The birds of Corsica. – (B.O.U. Checklist Series) Tring, publ. **17**: 171 pp.
- TYRBERG, T. (1991): Arctic, montane and steppe birds as glacial relicts in the West Palearctic. – *Ornithol. Verh.*, **25**: 29–49.
- ,– (1998): Pleistocene birds of the Palearctic: a catalogue. – *Publ. Nuttall Ornitholog. Club. (R.A. PAYNTER Jr. Ed.)* Cambridge, publ. **27**: 720 pp.
- WEESIE, P.D.M. (1982): A pleistocene endemic island form within the genus *Athene*, *Athene cretensis* n. sp. (Aves, Strigiformes) from Crete. – *Proc. Koninkl. Nederl. Akad. Wetensch.*, (B) **85**(3): 323–336.
- ,– (1988): The quaternary avifauna of Crete, Greece. – *Palaeovertebrata*, **18**(1): 94 pp.
- ,– (1999): Les oiseaux du Pléistocène supérieur de la grotte de Corbeddu, Sardaigne. – In: REUMER, J.W.F. & DE VOS, J. (Eds): *Elephants have a snorkel! Papers in honour of PAUL Y. SONDAAR*. – *DEINSEA*, **7**: 401–409.

Appendix 1. List of recent specimens examined for comparisons.

*Morphnus guianensis* BM 1851.12.2.10; *Harpia harpyja* BM 1862.3.19.14, BM 1909.8.18.1; *Pithecophaga jefferyi* BM 1910.2.11.1A, BM S/1961.23.1; *Ictinaetus malayensis* BM 1969.1.1; *Aquila pomarina* AC 1997.271, AC 1997.272, BM 11 B, BM 1845.1.12.11, BM 1898.5.7.5 MPOC; *A. clanga* Pallas AC 263, BM 424 A, BM 1972.1.58, BM 1952.1.181, IPH 787, IPH 786, IPH 614, UCBL 89.1, UCBL 89.2; *A. rapax* (Temm.) AC 1864.26, AC 1982.11; *A. nipalensis* (Hodgson) AC 1873.292, BM S/1980.11.4, BM S/1952.3.58, BM 1954.42.3, BM S/1923.9.32, BM S/1923.9.31, UMMZ 41g; *A. heliaca* Savigny BM 1954.30.48, BM 1845.1.12.8, BM 1845.1.12.8 bis, BM S/1998.90.6, H 68.4, H 74.3.10, H 77.8, H C.14.58, IRSN 3898, IRSN 6084, ZMUC 9242, USNM 808; *A. adalberti* (Brehm) UMMZ 161, UMMZ 172; *A. wahlbergi* BM 1904.10.29.21; *A. chrysaetos* (L.) AC 1995.4, AC 1996.10, AC 1930.152, AC 1890.3996, AC 1997.103, AC 1994.22, AC 1990.1, AC 1891.956, AC 1897.1, AC 1911.332, AC 1996.45, BM S/1973.66.57, BM S/1952.3.191, BM S/1952.3.192, BM 1898.5.7.2, BM 1954.30.46, BM 1930.3.24.260, BM 1846.3.18.3, BM 1898.5.7.3, BM 1869.12.22.10, BM 1858.5.4.444, BM 1891.7.20.11, H C.36.6., IPH 126, IPH 576, MCCI, MPOC, UCBL 86.4, UCBL 86.5, MF, PB (2 indiv.); *A. audax* BM 1930.3.24.246; *A. verreauxii* BM 1860.4.23.7; *Polemaetus bellicosus* BM S/1954.30.43; *Lophaetus occipitalis* BM 1850.8.15.61, BM S/1955.4.6; *Spizaetus cirrhatus* BM S/2002.45.1; *S. nipalensis* BM S/2002.44.1; *S. ornatus* BM S/1952.1.177; *Stephanoaetus coronatus* BM S/1954.30.42; BM *Hieraaetus fasciatus* (Vieillot) AC 1881.135, AC 1870.326, AC 1997.946, IPH 603, BM 1847.10.21.50, BM S/1996.69.22, BM 1898.12.31.1, BM 1952.1.180, BM 1954.30.45, UCBL 91.1, UCBL 91.2, PB (2 indiv.).

endix 2 (1-4). Tables showing the measurements of all the specimens of *Aquila nipaloides*, along with those of the recent eagle species considered in the comparisons. means estimated measurement. n less than 4, every individual measurement is shown. For n greater than 4, the mean is indicated (bold), then the min. and max separated by a dash, then the standard deviation, then n the sample or the mandibula in *A. hastata* the measures are inferred after the figure 5 in Parry et al. (2002).

Mandibula measurements	mdb1	mdb2	mdb3	mdb4	mdb5	mdb6	mdb7	mdb8	mdb9	mdb10	mdb11	mdb12	mdb13
<i>Aquila nipaloides</i>													
M 50-51	99,6 (81,5-92,2) 4,4 n=4	15,1 <b>15,8</b> (15,1-17,2) 0,8 n=5	72 <b>60,3</b> (57,8-63,8) 2,3 n=5	50,7 <b>42,7</b> (40,1-46,2) 2,6 n=4	21,9 <b>19,7</b> (17,9-21,3) 1,4 n=4	23,7 20,9; 21,2	103,6 <b>90,6</b> (87,1-95,5) 3,6 n=4	7,4 <b>7</b> (6,4-7,2) 0,4 n=4	82,4 65,2; 68,6; 74,5	3,15 3	76,2 88,3	6,6 6,6	10,4 10,9
<i>A. adalberti</i>	87	16,8	60	41,9	21,2		90,6	8					
<i>A. nipalensis</i>	<b>90,2</b> (83,5-98,1) 5,3 n=5	<b>15</b> (13,1-16,9) 1,5 n=5	<b>59,2</b> (54,6-65,1) 4,1 n=5	<b>43</b> (38,9-46,5) 2,7 n=5	<b>17,4</b> (14-20,7) 3 n=5	<b>21,13</b> (20,3-22,4) 0,954 n=4	<b>93,7</b> (87,9-101) 5 n=5	<b>6,8</b> (5,8-8,1) 0,9 n=5	<b>74,7</b> (71,2-80,5) 3,8 n=5	<b>2,33</b> (2,2-2,4) 0,096 n=4	<b>78,5</b> (73,7-85,6) 5,39 n=4	<b>5,38</b> (5,2-5,6) 0,171 n=4	<b>9,7</b> (9-10,5) 0,6 n=4
<i>A. rapax</i>			50,9; 51,2; 52,4			18,7; 19,2					63,7; 64; 66,3		7,9; 9,6
<i>A. hastata</i>	70e	11,5e	52e	36,5e	16e	18e	73e				62e		
<i>A. chrysaetos</i>		<b>17,14</b> (16,1-18,1) 0,796 n=5	<b>57,74</b> (52,3-62,8) 3,182 n=16			<b>21,02</b> (19,4-23,1) 1,146 n=16				<b>2,52</b> (2,4-2,9) 0,194 n=6	<b>71,43</b> (66,9-75,6) 2,621 n=16	<b>6,12</b> (4,2-7,1) 1,034 n=6	<b>10,91</b> (10,1-11,7) 0,505 n=14
<i>H. fasciatus</i>			<b>51,8</b> (51,1-52,5) 0,572 n=4			<b>18,48</b> (18-19) 0,55 n=4					<b>62</b> (59,3-62,9) 1,8 n=4		8,8; 9,2

extant



Humerus measurements		hum1	hum2	hum3	hum4	hum5	hum6	hum6/hum1 ratio	hum4/hum1 ratio
<i>Aquila nipaloides</i> n. sp.	M 3 556	166	33	14,5	28,5	15	12,5	0,08	0,17
	M C4 +/- R 66				28,9	15,2	13		
	MPUR 4353		40,0e	18,3					
	MPUR 4355				35,7	18,6			
	MPUR 4356				33,1	17,1	14		
	MPUR 4358	219,7	42,2	20,1	35,3	18,6	16,3	0,07	0,16
	MPUR 4359		41,4	20,6					
	MPUR 4360		39,9	19,8					
	MPUR 4361		40,3	19,4					
	MPUR 4362		40,4						
	MPUR 4363				35,2	18,1			
	MPUR 4367				33,2	16,5	13,6		
	MPUR 4369	179,5			33	17,5	14	0,08	0,18
	MPUR 4370	185,8	39,5	16,1	34,1	17,8	14,3e	0,08	0,18
extant	<i>A. heliaca/adalberti</i>	183,5 (180-193) 5,91 n=10	35,53 (34,3-39,4) 1,896 n=9	16,53 (14,5-17,6) 1,089 n=6	30,22 (29-32,3) 1,415 n=10	15,9 (15,1-17,6) 0,8 n=10	12,26 (11,2-13,5) 0,76 n=10		
	<i>A. nipalensis</i>	178,7 (166,8-196,3) 13,615 n=5	34,2 (32,1-37,5) 2,769 n=5	15,3 (13,8-18) 2,181 n=5	29,2 (27,2-31,5) 1,899 n=5	15,6 (14,9-16,5) 0,748 n=5	11,8 (11-12,6) 0,743 n=5	0,07	0,16
	<i>A. rapax</i>	150,4; 150,6	28,3; 28,5	12,7; 13,3	24,3; 24,9	12,6; 13,4	9,5; 9,6		
	<i>A. chrysaetos</i>	188,83 (166-225) 12,619 n=26	38,08 (32,8-41,9) 2,574 n=24	16,05 (13,5-19,2) 1,607 n=22	33,34 (29,4-36,2) 2,029 n=28	17,3 (12,2-19,1) 1,521 n=22	13,74 (11,7-16,7) 1,053 n=27	0,07	0,18
	<i>H. fasciatus</i>	147,57 (139,7-157,9) 5,787 n=10	30,32 (28,2-32,3) 1,123 n=9	13 (12,5-13,7) 0,5 n=9	25,46 (22,3-27) 1,24 n=10	14,57 (13,2-17,9) 1,541 n=7	10,88 (9,9-12,1) 0,731 n=11		

Ulna measurements		uln1	uln2	uln3	uln4	uln5	uln6
<i>Aquila nipaloides</i> n. sp.	MPUR 4327		24,6	19,8			
	MPUR 4328		22,6	18,2			
	MPUR 4329	244,5	23,8	20,4	15,9	17,6	10,2
	MPUR 4330	234,5	22,8	18,3	14,6	16,5	11,4
	MPUR 4332				16,2	17,8	
	MPUR 4334				13,4	16,3	9,8
	MPUR 4335				15,5	17,6	10,5
	MPUR 4336				14,2	16	9,9
	MPUR 4337		24,4	19,9			
	MPUR 4338		25,7	20,7			
	MPUR 4339		25,5	20,4			
	MPUR 4340		25,6	19,9			
	MPUR 4342	244,6	24,9	19,8	14,5	17,8	10,2
	MPUR 4345	233,1	22,9	18,6	14,9	16,3	9,9
	MPUR 4346	228,8	21,8	18,6	13,2	16,6	11,9
	MPUR 4347	255,2	23,6	20,5	15,3	17,9	9,7
	MPUR 4348				15,7	18	
MPUR 4351				14,8	18,3		
extant	<i>A. heliaca/adalberti</i>	207; 210	19,6; 20,2	16; 17	13,2; 14	15,7; 15,7	8,9; 9,1
	<i>A. nipalensis</i>	198,3; 209,2	20; 20,2; 22	15,8; 16; 17,5	13; 13,6; 13,9	14; 14,9; 15,7	8,35; 8,6; 10,7
	<i>A. chrysaetos</i>	218,25 (196-257) 15,924 n=13	21,66 (19,8-23,3) 1,167 n=12	18,31 (12,5-21,1) 2,273 n=12	15,18 (13,5-17,5) 1,202 n=12	16,75 (14-18,8) 1,491 n=11	10,27 (8,6-11,6) 0,798 n=13
	<i>H. fasciatus</i>	180,63 (174-193,2) 8,827 n=4	16,5; 17	14,3; 16	12; 12	12,8; 13,7	8,18 (7,8-8,6) 0,386 n=4

Carpometacarpus measurements		cmc1	cmc2	cmc3	cmc4	cmc5	cmc6
<i>Aquila nipaloides</i> n. sp.	Cos 1244		21,8	9,2			
	<i>A. heliaca/adalberti</i>	101,68 (96-107,3) 6,215 n=4	24,1 (23-25,8) 1,361 n=4	10,1	15,58 (14,1-17,5) 1,441 n=4	10,28 (9,7-10,5) 0,386 n=4	4,9
extant	<i>A. nipalensis</i>	94,4 (90,3-102,2) 5,5 n=4	21,6; 21,9; 23,6	8,9; 9,2; 9,3	13,7; 14,4; 14,5	10; 10; 10,2	4,8; 4,9; 5
	<i>A. rapax</i>	82,1; 83,5	18,7; 19,6	7,7; 7,9	12,5; 12,7	8,8; 9	4,3; 4,4
	<i>A. chrysaetos</i>	104,66 (92,1-117,5) 6,16 n=28	26,16 (23,3-28,7) 1,618 n=25	10,51 (9-11,8) 0,858 n=25	16,57 (14,2-21,2) 1,965 n=21	12,03 (10,4-18,5) 1,669 n=22	5,7 (4,8-6,6) 0,497 n=16
	<i>H. fasciatus</i>	85,31 (79,6-90,9) 3,883 n=11	20,5 (19,5-21,8) 0,807 n=8	8,57 (8-9,2) 0,427 n=9	13,6 (12,2-16) 1,362 n=10	9,23 (8,6-9,8) 0,409 n=9	4,8 (4,5-5,1) 0,283 n=5

Femur measurements		fem1	fem2	fem3	fem4	fem5	fem6	fem4/fem1 ratio	fem6/fem1 ratio
<i>Aquila nipaloides</i> n. sp.	MPUR 4297	133,6	25,7	14,7	25,1				
	MPUR 4298	135e	26,5	16,1			11,2	0,11	0,19
	Cast3 1133		25	14,2			12,1	0,12	
extant	<i>A. heliaca/adalberti</i>	116,8	25,77 (24,1-27,4) 1,259 n=7	14,4	25,8 (24,3-27,3) 1,1 n=6	19,97 (16,3-21,9) 1,926 n=6	11,2	0,12	0,22
	<i>A. nipalensis</i>	100,1; 102,4	25,7		25,7	20,7	10; 10,3		0,25
	<i>A. chrysaetos</i>	127,37 (114,3-136,4) 5,492 n=22	27,87 (24,5-30,8) 1,717 n=20	15,82 (14,1-17,2) 1,027 n=20	28,53 (24-31,8) 2,285 n=20	20,99 (17,1-25) 2,027 n=16	12,72 (10,9-14,8) 0,985 n=22	0,12	0,22
	<i>H. fasciatus</i>	103,37 (95,3-107,7) 4,093 n=7	21,84 (20,2-24,3) 1,253 n=7	12,56 (11,2-14,5) 1,04 n=7	22,5 (20,9-24,1) 1,1 n=7	16,13 (14,7-18) 1,075 n=7	10,08 (8,9-10,9) 0,725 n=8	0,12	0,22

Tarsometatarsus measurements		tmt1	tmt2	tmt3	tmt4	tmt5	tmt6	tmt4/tmt1 ratio
<i>Aquila nipaloides</i> n. sp.	MPUR 4286	104	20,5	16,2	22,3	14	10,8	0,21
	Cast3 680	120	24		24,8	14,2	11,3	0,21
	Cast3 1132	112,4	21,4	16,1	23,7	14,4	10	0,21
	Cos 4335		19,6	14,8				
	Cos 5658-8676	104e	20,7	16,5	22,8		9,8	0,22
extant	<i>A. heliaca/adalberti</i>	95,57 (92-95,6) 3,045 n=9	19,55 (17,8-21,1) 1,11 n=9	15,15 (13,9-16,2) 0,849 n=8	21,31 (19,5-23,1) 1,224 n=8	12,4 (11,5-13,5) 0,829 n=4	9,26 (8,44-10,2) 0,7 n=9	0,22
	<i>A. nipalensis</i>	98,2 (90,3-103,4) 6,039 n=5	19,4 (17,9-21,3) 1,596 n=5	15,2 (14,2-16,8) 1,218 n=5	21,2 (19,5-23,1) 1,486 n=5	13,1 (11,7-14,6) 1,42 n=4	9,3 (8,4-10,4) 1,028 n=5	0,22
	<i>A. rapax</i>	80,8; 81,2	15,1; 15,9	12; 12,9	16,9; 18,9	11,2	7,5; 7,5	
	<i>A. chrysaetos</i>	105,06 (95-112,1) 4,375 n=26	22,75 (19-25,6) 1,624 n=26	17,71 (15,3-19,3) 1,203 n=16	24,83 (21,8-27,3) 1,713 n=25	15,93 (14-17,7) 1,173 n=16	10,66 (8,4-12,5) 1,02 n=21	0,24
	<i>H. fasciatus</i>	101,42 (92,8-105,6) 4,059 n=12	18,03 (17-19,8) 1,054 n=12	13,93 (12,9-14,9) 0,706 n=10	20,48 (18,7-21,9) 0,941 n=12	12,92 (12-13,9) 0,57 n=9	8,85 (7,8-10) 0,746 n=8	0,20

Pedal phalanx 1 of digit I measurements		phape11 1	phape11 2	phape11 4	phape11 6
<i>Aquila nipaloides</i> n. sp.	CB 86 1678	33	16,2	10,3	8,4
	CB 84 28	33,3	16,6	10,3	8,9
	CB 112	32,3	16,1	10,1	9,8
	Rp 256	30,9	14,4	8,9	7,4
	Rp 257	31,2		9,5	8,5
	Rp 111	32,8		10,4	9
	Rp 116	31,8	16,6	9,6	8,1
	Rp 110	30,8	16,8	9,8	8
	Rp II 2	33,5	16,8	10,9	9
	MPUR 4934	34,2	16,2	9,5	8,4
	MPUR 4935	34,2	16,2	9,1	8,4
MPUR 4936	33,7	16,8	9,4	8,8	
Cos 4466	33,7	16,3	9,2	8,4	
<i>A. chrysaetos bonifacii</i> St-Estève-Janson	36,31 (33-41) 2,544 n=13	14,8 (13,1-16,4) 1,005 n=13	9,24 (8,4-10,5) 0,608 n=13	7,61 (7,1-8,3) 0,475 n=13	
extant	<i>A. heliaca/adalberti</i>	29; 31,8	14,3; 15	7,9; 8,55	6,8; 8,95
	<i>A. nipalensis</i>	24,7; 24,9	12,8; 14	7,2; 7,3	6,6; 7
	<i>A. rapax</i>	25,8	11,1	6,6	5,4
	<i>A. chrysaetos</i>	39,73 (36,3-45,9) 2,293 n=14	17,17 (15,6-18,7) 1,056 n=13	9,88 (8,3-10,9) 0,747 n=14	8,24 (5,5-10,3) 1,223 n=14
	<i>H. fasciatus</i>	33,43 (30,4-35,7) 1,729 n=12	12,87 (11,4-13,8) 0,739 n=12	7,63 (6,3-8,5) 0,657 n=11	6,05 (5-7) 0,585 n=12

Pedal phalanx 2 of digit I measurements		php2I 1	php2I 2	php2I 4	php2I 5
<i>Aquila nipaloides</i> n. sp.	CB I 202	11,2	16,6	9,2	5,1
	(cf) CB 84 A 123	11,2	15,6	9	5,2
	Rp 120	11,8	17,5	9,3	4,8
	Rp 119	11,4	16,6	9,5	5,2
	Rp 123	12,2	17,2	8,9	5
	Rp 258	10,2	15	7,7	4,7
	MPUR 4924	12,4	17,2	9,7	5,4
	Cos 6229	10,5	16		4,2
<i>A. chrysaetos bonifaci</i> St-Estève-Janson				10,29 (9,4-12) 0,831 n=9	
extant	<i>A. heliaca/adalberti</i>	10, 11,3	14,7; 17,7	7,9; 9,9	4,7
	<i>A. nipalensis</i>	8,8	13,2	8	4,3
	<i>A. chrysaetos</i>	13,11 (11,4-14,6) 0,998 n=11	19,68 (16,6-22,1) 1,592 n=11	10,65 (8,9-11,9) 0,842 n=13	5,42 (4,1-6,4) 0,609 n=10
	<i>H. fasciatus</i>	10,36 (9-10,8) 0,655 n=7	16,51 (14,6-17,5) 1,042 n=7	8,56 (7,2-9,3) 0,704 n=7	4,69 (3,9-5,15) 0,485 n=7

Pedal phalanx 2 of digit II measurements		php2II 1	php2II 2	php2II 3	php2II 4	php2II 5	php2II 6
<i>Aquila nipaloides</i> n. sp.	CB 84 A 171	31,2	9,4	9,9	7,8	7	6,5
	CB 84 A 082	29,2	9,2	9,9	8,6	7,7	7,6
	Rp 155	27,1	9,8		7,9	7,3	7
	Rp II 7	30,9	9,2	8,8	8,5	7,2	7,4
	Rp II 6	21,9	9,1	7,9	7,8	7,2	6,8
	<i>A. chrysaetos bonifaci</i> St-Estève-Janson	32,35 (30,2-35) 2,175 n=4	11,28 (10,5-12,1) 0,714 n=4		9,08 (8,6-9,7) 0,519 n=4		7,48 (6,8-8,1) 0,59 n=4
extant	<i>A. heliaca/adalberti</i>	24,5; 24,6; 27,3	8,9; 9,1; 10	7,8; 7,9; 9,3	7; 7,2; 8,3	6,9; 7,1; 8,3	6,6; 7
	<i>A. rapax</i>	23,1		6,8	6,1	5,8	5
	<i>A. chrysaetos</i>	33,43 (31,1-35) 1,283 n=10	11,13 (10,2-12,5) 0,892 n=10	10,46 (9,2-11,4) 0,852 n=8	9,13 (7,7-10,1) 0,717 n=10	8,54 (7,1-9,8) 0,948 n=7	7,61 (6,4-8,5) 0,677 n=10
	<i>H. fasciatus</i>	28,62 (24,8-30,9) 2,93 n=6	8,98 (8,3-9,4) 0,376 n=6	8,17 (7-9) 0,882 n=6	7,12 (5,8-8) 0,956 n=6	6,58 (5,4-7,3) 0,794 n=6	5,53 (3,9-6,4) 1,133 n=6

Pedal phalanx 4 of digit III measurements		php4III 1	php4III 2	php4III 3	php4III 4
<i>Aquila nipaloides</i> n. sp.	CB 101	6,6	10	5,4	4,4
extant	<i>A. heliaca/adalberti</i>	6,4; 8; 8,16	9,2; 11,9	6,1; 6,6	4,2
	<i>A. chrysaetos</i>	8,51 (7,3-11,1) 0,974 n=11	12,65 (11,2-13,8) 0,779 n=11	7,73 (6,4-8,5) 0,637 n=13	6
	<i>H. fasciatus</i>	6,87 (6,1-7,4) 0,461 n=7	11,25 (10-11,7) 0,613 n=7	6,32 (5,2-6,9) 0,608 n=6	4,96 (4,6-5,7) 0,439 n=5

## Explanation of the plates

### Plate 1

Postcranial elements of *Aquila nipaloides* n. sp. and one criterion to distinguish between *Aquila* and *Hieraaetus fasciatus*. The scale bars represent 10 mm.

Fig. 1 – *Aquila nipaloides* n. sp., probable female, paratype left humerus, Dragonara, MPUR 4358, caudal aspect.

Fig. 2 – *Aquila nipaloides* n. sp., probable male, paratype left humerus, Coscia abri sud, c. 3, Mac 556, caudal aspect.

Fig. 3 – *Aquila nipaloides* n. sp., paratype right ulna, Dragonara, MPUR 4329, caudal aspect.

Fig. 4 – *Aquila nipaloides* n. sp., paratype right ulna, Dragonara, MPUR 4329, cranial aspect.

Fig. 5 – *Aquila nipaloides* n. sp., holotype right femur, Dragonara, MPUR 4297, proximal aspect.

Fig. 6 – *Aquila nipaloides* n. sp., holotype right femur, Dragonara, MPUR 4297, cranial aspect.

Fig. 7 – Diagnostic criterion between the genera *Aquila* and *Hieraaetus* (with Western Palearctic species). Recent proximal tibiotarsi in proximal aspect, on the left *Aquila chrysaetos*, on the right *Hieraaetus fasciatus*.

Fig. 8 – *Aquila nipaloides* n. sp., paratype right tarsometatarsus from Cast3CG s.l., Cast3 680, cranial aspect.

Fig. 9 – *Aquila nipaloides* n. sp., paratype right posterior phalanx 1 of the digit I, Coscia grotte E, c. d', Cos 4466, dorsal aspect.

### Plate 2

Mandibulae of *Aquila nipaloides* n. sp. and of other *Aquila* species. The scale bar represents 10 mm.

Fig. 1 – *Aquila nipaloides* nov. sp., mandibula, Coscia abri sud, Mac 50-51, dorsal aspect.

Fig. 2 – *Aquila nipalensis*, mandibula, recent, BM 1980.11.4., dorsal aspect.

Fig. 3 – *A. nipalensis*, mandibula, recent, BM 1923.9.3.2., dorsal aspect.

Fig. 4 – *A. nipalensis*, mandibula, recent, BM 1952.3.58., dorsal aspect.

Fig. 5 – *A. heliaca*, mandibula, recent, BM 1998.90.6., dorsal aspect.

Fig. 6 – *A. chrysaetos*, mandibula, recent, BM S/1952.3.192., dorsal aspect.

Fig. 7 – *A. heliaca*, mandibula, recent, BM S/1954.30.48., dorsal aspect.



Antoine Louchart, Claudia Bedetti and Marco Pavia: A new species of eagle (Aves: Accipitridae).

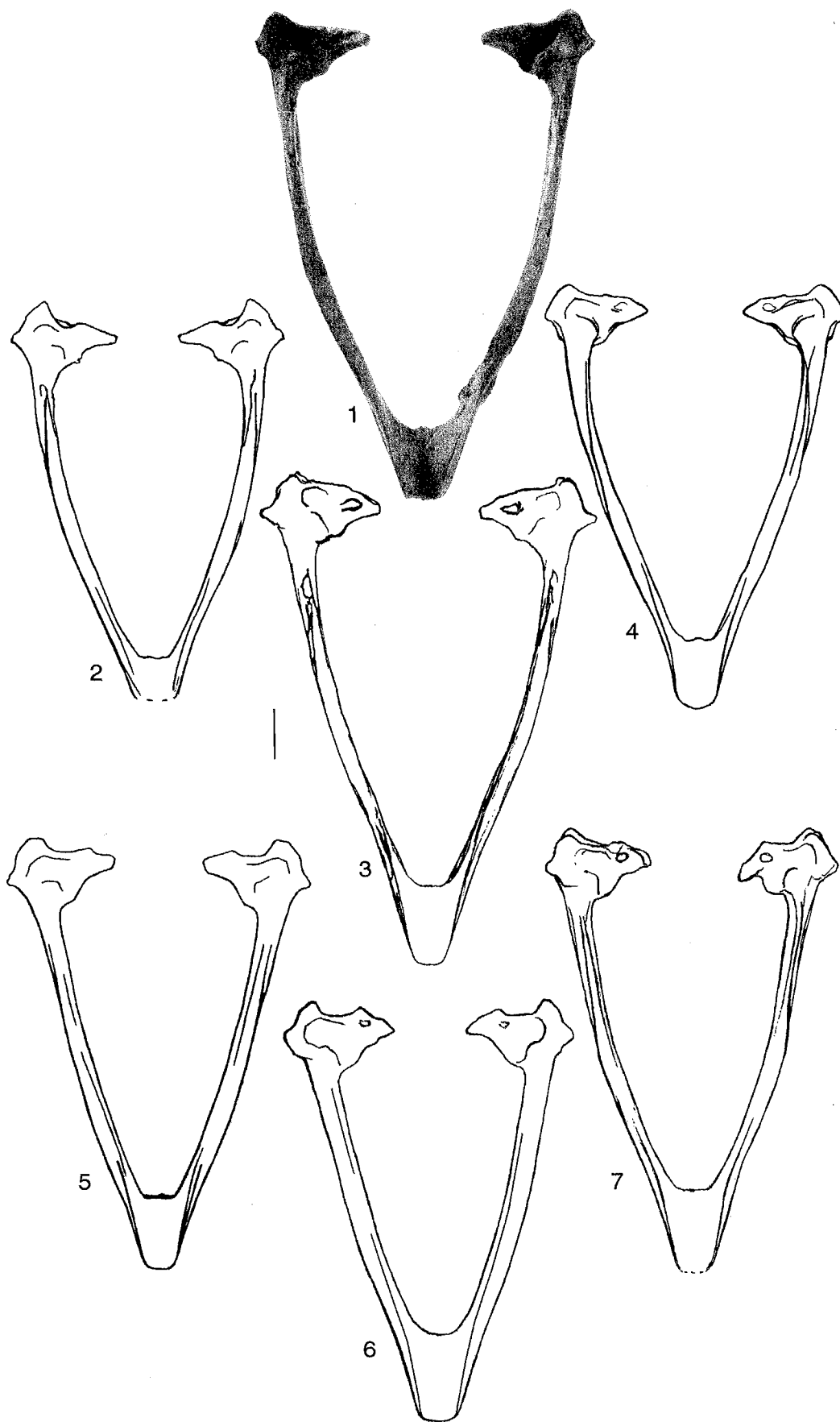

Antoine Louchart, Claudia Bedetti and Marco Pavia: A new species of eagle (Aves: Accipitridae).

