

Article

Effect of the Airblast Settings on the Vertical Spray Profile: Implementation on an On-Line Decision Aid for Citrus Treatments

Cruz Garcera ¹, Enrique Moltó ¹, Héctor Izquierdo ¹, Paolo Balsari ², Paolo Marucco ², Marco Grella ², Fabrizio Gioelli ² and Patricia Chueca ^{1,*}

¹ Centro de Agroingeniería, Instituto Valenciano de Investigaciones Agrarias (IVIA), Ctra. CV-315 km. 10.5, 46113 Moncada, Spain; garcera_cru@gva.es (C.G.); molto_enr@gva.es (E.M.); izquierdo_hecsan@externos.gva.es (H.I.)

² Department of Agricultural, Forest and Food Sciences (DiSAFA), University of Turin (UNITO), Largo Paolo Braccini 2, 10095 Grugliasco, Italy; paolo.balsari@unito.it (P.B.); paolo.marucco@unito.it (P.M.); marco.grella@unito.it (M.G.); fabrizio.gioelli@unito.it (F.G.)

* Correspondence: chueca_pat@gva.es; Tel.: +34-963-424-347

Abstract: Airblast sprayers are widely used for the application of plant protection products (PPP) in citrus. Adaptation of the vertical distribution of the spray cloud to the canopy (density, shape and size), is essential to deposit an adequate amount of PPP on the target and to reduce losses (drift, runoff). Vertical spray profiles of three air-assisted axial fan hydraulic sprayers with different configurations and settings were obtained to evaluate the effect of these settings on the vertical spray profile. From the analysis of the empirical results, the impact of operational settings (nozzle, air volume and flow rate) on treatment efficiency is assessed. The empirical database generated in this work has been employed to feed the Citrus VESPA model, a highly intuitive, web-based decision aid tool that helps farmers to easily estimate the vertical spray profiles generated by their particular sprayers and settings and how these influence deposition and potential drift. The tool can also be used to determine the effect and importance of adequately selecting, orienting and opening/closing nozzles and optimizing volume application rate and fan speed, in order to adjust the application to the actual vegetation, with the aim of saving resources and reducing risks to humans and the environment.

Keywords: axial-fan sprayer; pesticide treatment; phytosanitary application efficiency; vertical test bench; airflow speed; spray volume rate; nozzle type

Citation: Garcera, C.; Moltó, E.; Izquierdo, H.; Balsari, P.; Marucco, P.; Grella, M.; Gioelli, F.; Chueca, P. Effect of the Airblast Settings on the Vertical Spray Profile: Implementation on an On-Line Decision Aid for Citrus Treatments. *Agronomy* **2022**, *12*, 1462. <https://doi.org/10.3390/agronomy12061462>

Academic Editors: Adriana Correa, María Dolores Gómez-López and Jesús Montero Martínez

Received: 24 May 2022

Accepted: 15 June 2022

Published: 17 June 2022

Publisher's Note: MDPI stays neutral with regard to jurisdictional claims in published maps and institutional affiliations.



Copyright: © 2022 by the authors. Licensee MDPI, Basel, Switzerland. This article is an open access article distributed under the terms and conditions of the Creative Commons Attribution (CC BY) license (<https://creativecommons.org/licenses/by/4.0/>).

1. Introduction

The main objective of a plant protection product (PPP) spray treatment is to apply the optimal amount of the PPP on the crop to effectively control the population of the target pest or disease. However, during application, part of the spray does not reach the target and deposits on the ground, directly or by run-off from the vegetation, or is carried out from the treated area by air currents, which is known as drift. Studies of PPP spray mass balance have reported high spray losses during application [1–7]. Furthermore, huge variations of spray distribution on the canopies have been observed, because pesticide deposition depends on the vegetation [8–12], equipment [9–14], operational parameters [15–18], weather conditions [19] and spray mix properties [20,21]. PPP losses pose risks both to people (operators, bystanders, residents, etc.) and to the environment (fauna and flora) [22–27].

Raising social awareness about human health and the natural environment has prompted important legislative measures aimed at minimizing the risks associated with

the use of chemical PPP. In Europe, Directive 2009/128/EC establishes a framework to achieve the sustainable use of PPP [28]. Directive 2006/42/CE establishes marketing standards for PPP application equipment that guarantee its compliance with specific environmental requirements [29]. More recently, the European Green Deal, and more specifically the Farm to Fork Strategy, strives to reduce the overall use of agrochemicals in the European Union by 50% by 2030 [30]. Therefore, the improvement of PPP spray application efficiency is still a major challenge.

Airblast sprayers are the most widely used machines for the application of PPP in vertical crops (citrus, vineyards and other fruit trees, also known as 3D crops). They spray sideways and upwards into the canopies by means of an air flow (air assistance). They only require a tractor driver, who is the operator of the application, and have a very high hourly performance, which allows the application of the PPP at precise stages of pests or diseases for optimal control. They greatly reduce water consumption and production costs. The operator's exposure to the PPP can be lower in comparison with hand-held lances [12], especially if using cab tractors. However, if this equipment is not adequately set up, it can produce significant drift and ground deposition.

Any technical improvement that increases spray application efficiency helps meet the requirements set by legislation and produces benefits such as: (i) reduction of environmental and human exposure and contamination risks, (ii) improvement of pest control, and (iii) enhanced food quality and safety standards. Correct sprayer adjustment consists in the optimal selection of forward speed, air volume, liquid flow rate, nozzles and nozzle orientations that depend on the vegetation to be sprayed. Consequently, machine adjustment is a key issue for reducing human and environmental risks [31,32]. For overall optimization of deposition on the canopy, vertical airflow and spray patterns generated by airblast sprayers must be considered concurrently [33–36], and they depend on canopy size and geometry [37].

Sprayer adjustment, sometimes referred to as calibration, is aimed at: (i) adjusting the fan airflow rate and its orientation to the tree canopy to minimize off-target losses [35,36,38,39], (ii) balancing the distribution of spray volume between the right and left side of the airblast sprayer [40], (iii) selecting the proper number of active nozzles and setting their orientation to produce a spray vertical profile that matches the targeted canopy as closely as possible [9,36], and (iv) applying the most appropriate spray volume [18,41–45].

The spray vertical profile is defined as the pattern and distribution of the amount of liquid flow rate released by the machine at different heights at a certain distance. It depends on several factors: the type, number, position and orientation of the active nozzles in the equipment, the overall sprayer liquid flow rate and the fan configuration [45–48], as the spray liquid distribution is directly linked to the generated airflow pattern and the airflow characteristics [12,36,49]. Several methods have been used to determine the spray vertical profile, including: analysis of deposition on water-sensitive papers [50–52], analysis of the movement of drops using laser or ultrasonic techniques [53,54], determination of the deposition of tracers on passive collectors [55,56], thermography [57] and, most commonly, the use of vertical patternators, which are devices designed to collect spray over a range of heights, using ad hoc accumulators, such as discrete metal or plastic trays, discrete collectors made of absorbent material or lamellae, which can be arranged horizontally and/or vertically [36,58–65]. Bahlol et al. [66,67] recently developed a patternator capable of simultaneously measuring deposited spray and airflow.

Many approaches have been envisaged for analyzing the influence of different machine settings (e.g., number and position of active nozzles, overall liquid application, orientation of nozzle spray jets, quantity and direction of air flow, etc.) on the empirical vertical spray profile. The selected configurations to be tested depend on the characteristics of the targeted canopies (foliar density, height, shape, orchard layout, etc.).

Obtaining vertical spray profiles of machines is very time consuming, given the huge number of possible adjustments, and difficult to perform at the farmers' level. For this reason, Tamagnone et al. [68] developed an on-line tool for assessing the vertical spray

profile generated by different machine types and configurations commonly used in vineyards. This tool is aimed at helping farmers and technicians to learn quickly and intuitively the vertical spray profiles generated by their machines and how they can adapt it to the target canopies, constituting a valuable decision aid tool for reducing drift losses.

Citrus trees are the first fruit crop in the EU, covering around 520,000 ha. Major production is located in the South of Europe, mainly in Spain (300,000 ha), Italy (145,000 ha), Greece (45,000) and Portugal (21,000) [69]. Citrus grown in the Mediterranean area is mainly managed as wide hedgerows (trees are cultivated in rows with an almost rectangular ground projected area, without significant gaps along the row), or as globular individuals (ellipsoidal canopies, with gaps between trees in a row). In any case, adult trees have a non-negligible canopy width (2–3 m). Additionally, citrus canopies have a very high foliar density. For this reason, high volume rates are usually necessary for effective PPP distribution. Most applications are performed with airblast sprayers, provided with axial fans and a high number of nozzles, driven at low forward speeds (1–3 km/h). This type of application scenario is very different from the one in vineyards. Consequently, a different tool for assessing vertical spray profiles in citrus PPP treatments was required and has been developed within the framework of the European PERFECT LIFE project (PEsticide Reduction using Friendly and Environmentally Controlled Technologies, <https://perfectlifeproject.eu/es/> (accessed on 10 June 2022)). The new tool is named the Citrus VERTICAL SPRay Assessment tool (Citrus VESPA tool).

This work shows the foundation principles of the Citrus VESPA tool. It explains the process of data acquisition and treatment and how the different types of sprayers and their settings affect the vertical spray distribution pattern.

2. Materials and Methods

2.1. Factors Affecting the Vertical Spray Profile

2.1.1. Experimental Design

A series of tests aimed to assess the effect of the configuration of air-assisted hydraulic sprayers commonly used in citrus growing on the vertical spray profile were carried out. Thus, the volume of liquid sprayed at different heights above the ground was measured for 48 configurations, resulting from the combination of the studied factors shown in Table 1 on three types of commercial axial fan air-assisted hydraulic sprayers. One of them had a triangular air outlet deflector, with one boom of nozzles and a 920 mm diameter fan, rotating counterclockwise, hereafter the T sprayer (Twister FR S5, Mañez y Lozano S.L., Valencia—Spain). The other two had a circular air outlet deflector, one with 2 channels of air outlet, each one with one boom of nozzles located in its middle width, and a fan diameter of 810 mm, also rotating counterclockwise, hereafter the C2 sprayer (Futur Qi 9.0, Fede Pulverizadores, Valencia—Spain), and the other with one boom of nozzles, hereafter the C1 sprayer, which was the same machine but just activating the outer boom of nozzles, thus simulating other simpler and more common equipment for citrus. When description or results are similar or apply to both C1 and C2 sprayers, both will be referred as C sprayer.

Three test replicates per sprayer side and configuration were performed. Results were saved in a database that subsequently fed the Citrus VESPA tool.

Table 1. Study factors for the evaluation of the vertical spray profile.

FACTOR	FACTOR LEVELS
Spray cloud adjustment	Adjusted to vegetation
	Not adjusted to vegetation
Nozzle type	Conventional hollow cone (Fine droplets)
	Hollow Cone Air Induction (Coarse droplets)
Spray volume rate	High

	Low
Fan gear-box speed	High
	Low

Both the T and C sprayers were powered by a 90CV tractor (TN95NA, New Holland, PA, USA). In all the tests, the revolutions of the power take-off were set at 480 rpm, and the working pressure at the nozzles was between 9 and 16 bar (pressure was adjusted for each combination sprayer-volume rate to obtain the necessary flow rate of the sprayer with the required nozzle–boom configuration).

The position and orientation of each nozzle holder were characterized in the T and C sprayers before the tests. Regarding the position, in both sprayers, height from the ground (H , cm) and distance to the vertical chord that crosses the center of the fan (D , cm) of each nozzle holder were measured (Figure 1). The orientation was described with the angles α and β indicated in Figure 2. In the C sprayer, nozzle holders were individual (one for each nozzle), and their orientation could be modified to adjust the spray cloud. Nozzle holders were oriented so that the axis of the spray jet was parallel to the air flow and perpendicular to the advance of the sprayer, so β had a value of 90° in all cases, and only α could be changed (Table 2). In the T sprayer, nozzles are installed in a circular triple nozzle holder, without the possibility of changing their orientation or position (Figure 3). In each nozzle holder, there are three nozzles arranged radially, 120° apart, one of them oriented so that the axis of the spray jet is approximately parallel to the air flow, and the other two oriented so that the axis of the spray jet of one of them is mainly directed towards the fan and that of the other towards the tractor (Table 3).

In both sprayers, the booms of the nozzles on each side of the equipment were symmetrical.

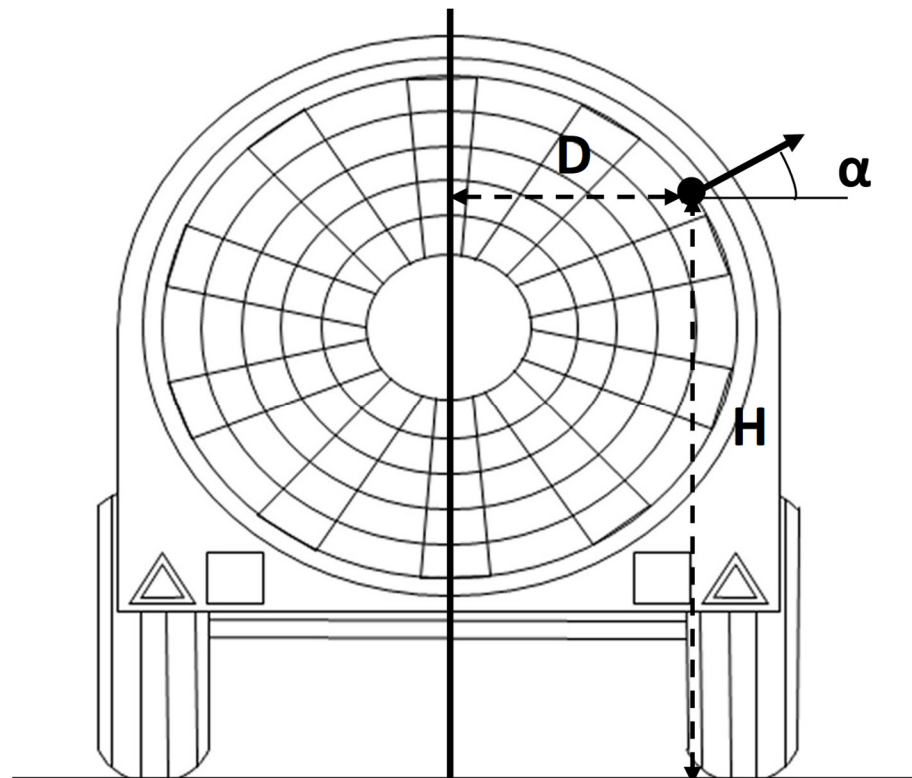

Figure 1. Characterization of the position of the nozzles in both sprayers.

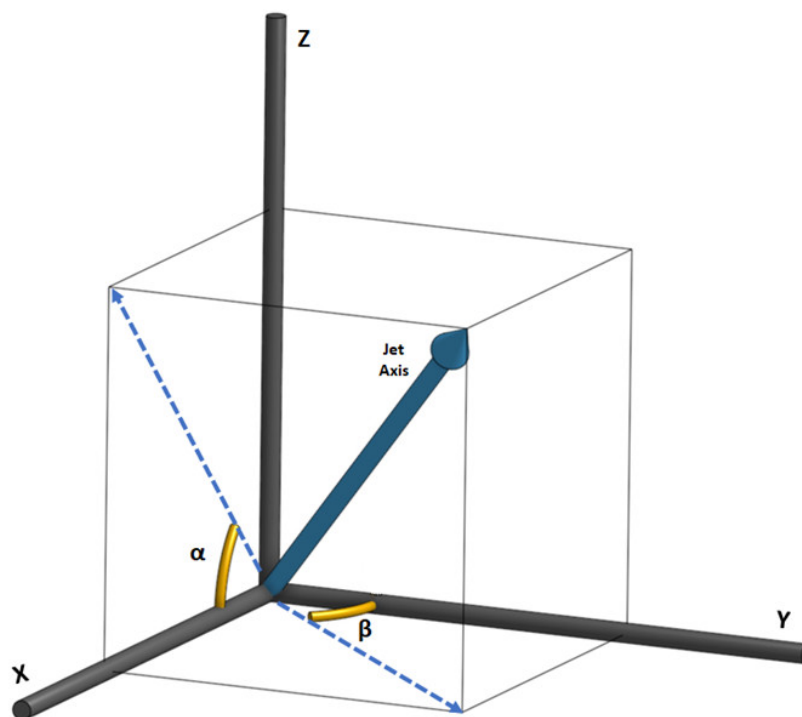

Figure 2. Schematic of the angles α and β that defined the orientation of the nozzles in both sprayers, where X: horizontal axis, parallel to the main air flow direction, and perpendicular to the longitudinal sprayer axis; Y: horizontal axis, perpendicular to the main air flow direction, and parallel to the longitudinal sprayer axis; and Z: vertical axis.

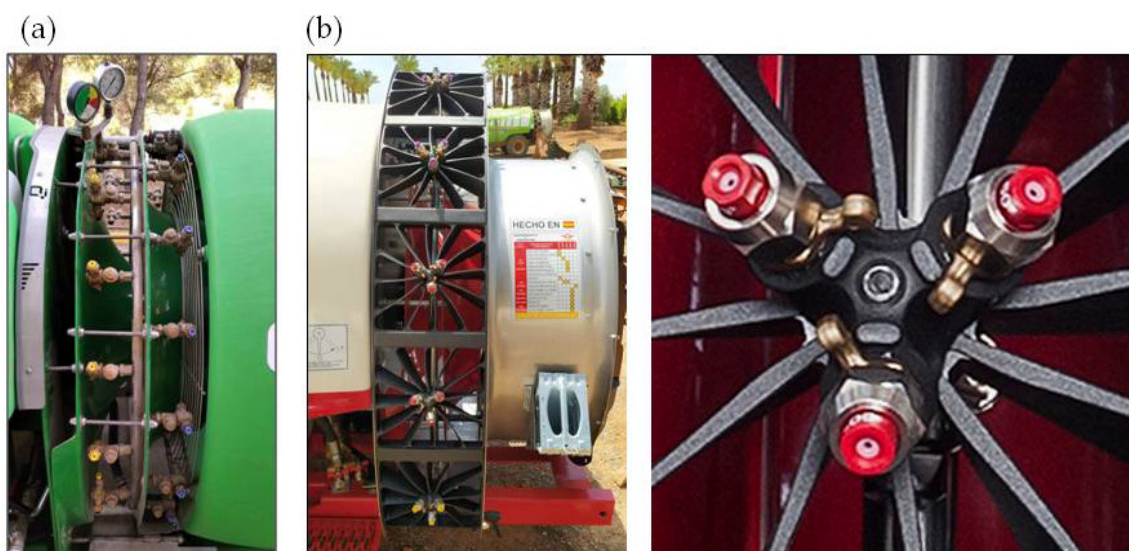

Figure 3. (a) Nozzles' boom of the C sprayer (C1 and C2), and (b) of the T sprayer, with a detail of the circular triple nozzle holder.

Table 2. Position and orientation of the nozzles in the air-assisted sprayer with a circular outlet deflector (C sprayer). All the nozzles were considered for the sprayer C2, while nozzles between numbers 7–13 were considered for the sprayer C1. D: distance of the nozzle from the vertical central axis of the fan. H: height of the nozzle with respect to the ground. α : angle formed by the projection of the nozzle in the XZ plane (β was 90° in all cases).

Nozzle	Boom	D (cm)	H (cm)	α (°)
	Inside	14.0	144.0	60
2	Inside	29.5	136.0	60
3	Inside	40.5	123.0	40
4	Inside	46.0	107.0	25
5	Inside	47.0	91.0	5
6	Inside	47.5	74.0	0
7	Exterior	6.5	146.0	70
8	Exterior	22.5	139.5	60
9	Exterior	35.0	129.0	30
10	Exterior	42.5	115.0	15
11	Exterior	46.0	97.5	5
12	Exterior	45.5	81.0	0
13	Exterior	40.0	65.0	0

Table 3. Position and orientation of the air-assisted sprayer with a 1-boom triangular outlet deflector (T sprayer). D: distance of the nozzle from the central axis of the fan. H: height of the nozzle with respect to the ground. α : angle formed by the projection of the nozzle in the XZ plane. β : angle formed by the projection of the nozzle in the XY plane.

Nozzle Group	Nozzle	D (cm)	H (cm)	α (°)	β (°)
1	1	12.5	154.0	95	85
	2	19.0	151.0	55	125
	3	19.0	151.0	55	70
2	1	43.5	133.5	20	90
	2	40.0	136.5	55	110
	3	40.0	136.5	55	60
3	1	57.0	106.5	-5	95
	2	54.5	111.0	50	115
	3	54.5	111.0	30	65
4	1	66.0	81.0	-20	95
	2	62.5	86.0	25	120
	3	62.5	86.0	30	65
5	1	64.5	53.0	-45	95
	2	66.0	58.0	25	100
	3	66.0	58.0	5	70

- Adjustment of the spray cloud to the canopy

This factor was analyzed at two levels: not adjusted (all nozzles working) and adjusted (closing specific nozzles to adapt the spray cloud to a standard canopy). A vegetation height of 2.40 m (with canopy skirts at a height of 0.50 m from the ground, and a total tree height of 2.90 m), a diameter across the row of 3.00 m, and a row spacing of 5.50 m was considered as standard. Adjustment of the spray cloud to the canopy was visually confirmed in an orchard with such characteristics by closing the nozzles not spraying the canopy. The resulting active nozzles are shown in Figure 4.

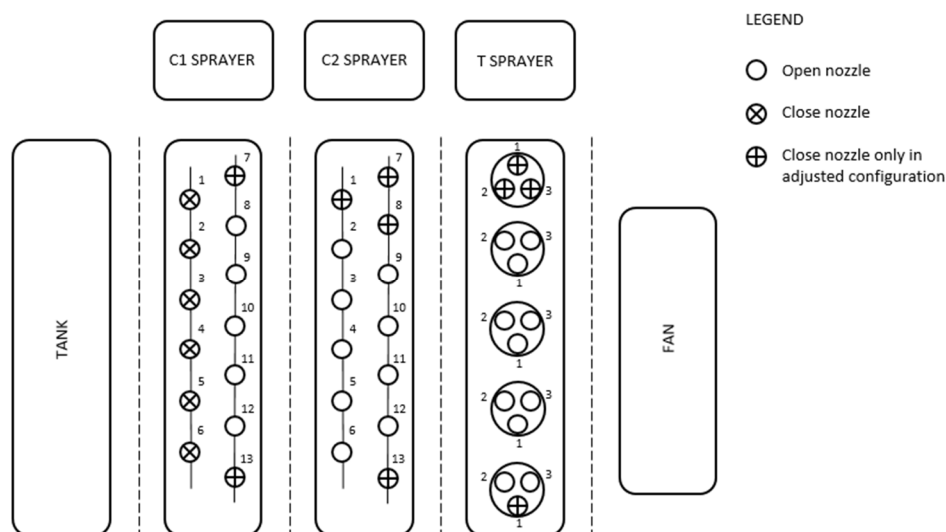

Figure 4. Active nozzles in the applications with adjustment to the vegetation in the three sprayers.

- Nozzle type

This factor was analyzed at two levels: conical turbulence nozzles, namely, conventional hollow cone nozzles, which produce fine and very fine droplets (Albuz, ATR 80, Solcera, Évreux—France), and drift-reducing nozzles with air injection, which produce coarse and extremely coarse droplets (Albuz, TVI 80, Solcera, Évreux—France). The boom configuration used for each treatment is shown in Appendix A, indicating the nozzle colors and their flow rate for the working pressure used for each treatment.

- Spray volume rate

Two spray volume rates were tested, namely, low and high volumes. Their values (approximately 1000 L/ha and 3000 L/ha, respectively) were those commonly employed in real applications in standard citrus orchards. Appropriate nozzles at conventional working pressure (between 9 and 16 bar) were selected for adjusted applications. The same nozzles were fitted along the booms in the C1 and C2 sprayers. Meanwhile, when applications were performed with the T sprayer, nozzles were combined along the boom: those with the highest flow rate were located in the center of the booms and those with lower flow rates were mounted on the extremes. The ratio between the highest and lowest flow rates were the same for the different combinations of volume rate/nozzle type. Actual spray volumes in adjusted applications were of 1068 ± 66 L/ha as low volume, and 2763 ± 272 L/ha as high volume.

For non-adjusted applications, in the C1 and C2 sprayers, the same nozzles were used to complete the boom. In the T sprayer, the nozzles with the lowest flow rates were used. Actual spray volumes in non-adjusted applications were of 1458 ± 115 L/ha and 3783 ± 491 L/ha, respectively. The nozzle configurations and actual spray volume rates applied are shown in Appendix A.

It is worth mentioning that it was impossible to apply 3000 L/ha with coarse nozzles with the C1 sprayer, because the number of active nozzles for the adjusted application was not enough to supply the necessary total flow rate even considering the ones with the highest flow rate.

In all tests, it was verified that the difference between the nominal flow and the actual flow of the nozzles was less than 10% before the application.

- Fan gearbox speed

Two air gearbox speeds (low and high) were tested in each sprayer. Air speed at the fan outlet was measured with a hot-wire anemometer (VelociCalc Plus 8386A-M-GB, TSI Inc., Shoreview, MN, USA) placed perpendicular to the air outlet at the outlet channel points indicated in Figure 5. These points were located where the air outlet was not interfered with by any structural element of the sprayer such as nozzles, deflectors, etc. Measurement in each point was repeated three times, and the average values for sprayer C and sprayer T are shown in Appendix B, Tables A25 and A26. From these data, the average air speed in each outlet channel was calculated. Total airflow was calculated by multiplying this value by the outlet surface of each channel and considering the air incompressible. The equipment with a circular deflector produced airflows of 74,833 m³/h and 91,964 m³/h for low and high fan gearbox speeds, respectively. The equipment with a triangular deflector produced airflows of 66,000 m³/h and 83,189 m³/h for low and high fan gearbox speeds, respectively.

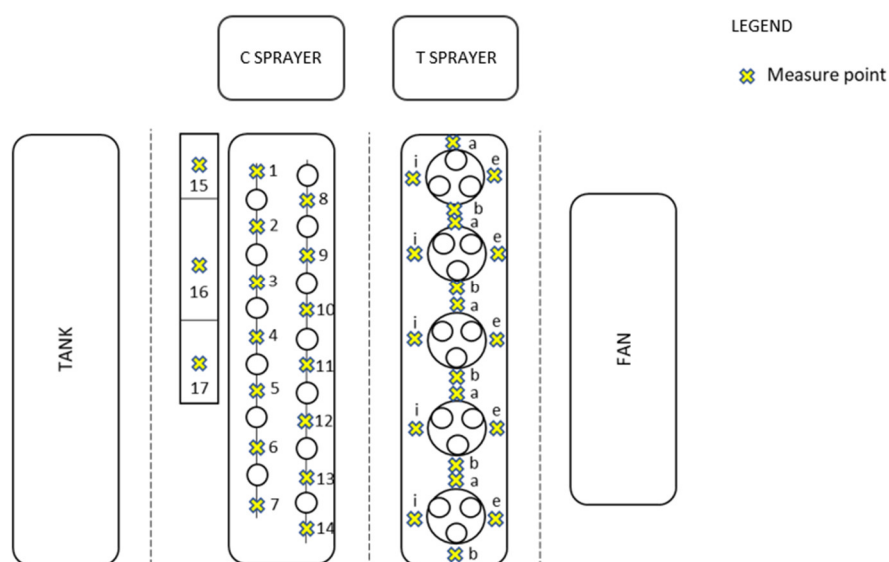

Figure 5. Points of measurement of air speed in the sprayers used. In the T sprayer the letters indicate a: top; b: down; i: inside; e: exterior.

2.1.2. Estimation of the Vertical Spray Profile

The vertical spray profile was obtained from a distribution evaluation system (paternator) (BV-20-400, AAMS-Salvarani, Maldegem (Belgium)). It had discrete collectors, which consisted of plastic trays of 0.20 × 0.22 m. Trays were located along two vertical columns with a horizontal distance between them of 0.18 m, with a total height between 0.50 and 4.50 m (Figure 6). The height of each tray was considered the average between the top and the bottom of the corresponding tray. The middle of the bottom tray was located at 0.60 m above the ground (liquid collection from 0.50 to 0.70 m), while the top tray was located at 4.40 m in height (liquid collection from 4.30 to 4.50 m). Liquid was collected every 0.20 m of height, in a total of 20 heights. The liquid collected by each tray was accumulated in graduated cylinders.



Figure 6. Vertical spray profile distribution evaluation system (left). Cylinders where the spray collected by height accumulates (right).

Each test repetition consisted of 5 passes of the tractor in parallel to the patternator, at a forward speed of 1.74 km/h (recommended in citrus) and a distance of 0.75 m, to simulate the closest distance of vegetation in the standard citrus orchard. Nozzles were opened 5.0 m before and closed 5.0 m after the patternator in order to properly sample the entire spray cloud width (Figure 7).

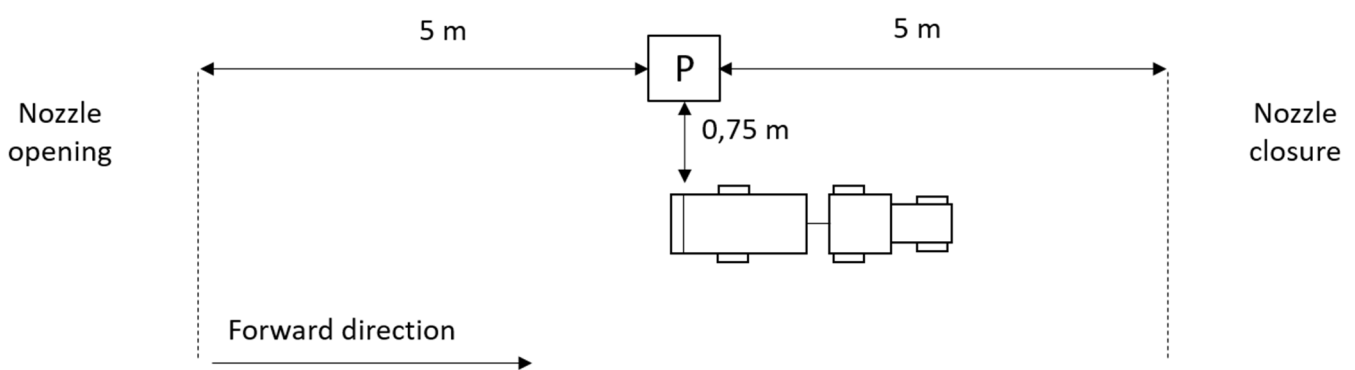

Figure 7. General scheme of the tests (P: Patternator).

Wind speed, temperature and relative humidity were monitored in all tests to ensure minimal effects of wind and droplet evaporation. Experimental conditions were negligible wind (<1 m/s), temperatures below 25 °C and relative humidity above 50%, in order to minimize both wind effects in the spray advance and droplet evaporation.

2.1.3. Data Analysis

The spray volume collected at each height and at each side of the sprayer was normalized by calculating the volume collected for every 100 L/ha applied according to Equation (1).

$$VRN_i(\text{ml}/(100 \text{ l/ha})) = 100 * \left(\frac{VR_i}{SPR} \right) \quad VLN_i(\text{ml}/(100 \text{ l/ha})) = 100 * \left(\frac{VL_i}{SPL} \right) \quad (1)$$

where VRN_i and VLN_i (mL/(100 L/ha)) are the normalized spray volume collected at height i and at each side of the sprayer, right and left, respectively; VR_i and VL_i (mL) are the spray volume collected at height i and at each side of the sprayer, right and left, respectively; SPR and SPL are the spray volume rate (L/ha) of the corresponding application on the right and left sides of the sprayer, respectively; and i is the corresponding patternator tray at height i . The sides of the sprayers are defined as looking at the sprayer from behind.

First, the percentage collected on each side of the sprayer with respect to the total volume collected on both sides was calculated. Next, the symmetry between the sides of each sprayer was evaluated by comparing the difference between the normalized volume collected on the left and right side. A symmetry index SI (%) was calculated according to Equation (2). The higher SI , the more symmetrical the sprayers' sides.

$$SI(\%) = 100 * \left(1 - \frac{\sqrt{\sum_{i=1}^{20} (VRN_i - VLN_i)^2}}{\sum_{i=1}^{20} VRN_i + VLN_i} \right) \quad (2)$$

where SI (%) is the symmetry index; i is the corresponding patternator tray; and VRN_i and VLN_i are the normalized volume (mL/(100 L/ha)) collected by tray i on the right and the left side of the sprayer, respectively.

For the statistical analysis of the factors affecting the vertical spray profile, normalized volume data were grouped into two zones. In this way, the trays collecting the spray between the heights 0.50 and 2.90 m (trays 1 to 12) were considered to correspond to the canopy, where the collected volume would mostly be deposited on the target vegetation. Trays between 2.90 and 4.50 m (trays 13 to 20) were considered to correspond to the space above the canopy. The values from each height range were added up to calculate the normalized volume corresponding to each of the two zones ("In the Canopy Zone" and "Above the Canopy Zone"). Although the amount of spray directed below the canopy would also be important to know due to its contribution to ground losses, it was impossible to acquire measurements below 50 cm because of design constraints of the patternator.

Multifactorial ANOVA, studying up to two-way interactions, was used to evaluate the effect of the studied factors (Adjustment/Nozzle/Spray Volume and Fan speed) on the normalized volume collected at each of the established zones (Canopy and above) for each Sprayer. The effect of the boom side was not considered in this analysis (left- and right-side measures were averaged) because they can only be avoided by modifying the design of the machines.

The hypothesis of normality was verified by drawing the normal probabilistic plot of the residuals. Homoscedasticity was tested from ANOVA of the squared residuals of each factor. The differences between variances for each factor were analyzed using Fisher's least significant difference (LSD) test. All tests were considered to be significant at 95%. Free programming software R (R Core Team, Vienna, Austria, 2020) and different R libraries were used (tidyverse, ggpubr, rstatix, readxl, plotrix) for the statistical analysis.

2.2. Data Treatment before Implementation in the CitrusVESPA Tool

Before entering the data in the CitrusVESPA tool, the coefficients of variation (CV, %) of the results for the three replicates at each height and side of each combination sprayer-configuration were calculated. Since all of them were under 30%, the average values of each data set can be considered as representative.

Then, the percentage of spray volume collected at each height and at each side of the sprayer with respect to the total spray volume collected throughout the entire vertical distribution system was calculated for each replicate, according to Equation (3).

$$R_i(\%) = 100 * \left(\frac{VR_i}{\sum_{i=1}^{20} VR_i + \sum_{i=1}^{20} VL_i} \right) \quad (3)$$

$$L_i(\%) = 100 * \left(\frac{VL_i}{\sum_{i=1}^{20} VR_i + \sum_{i=1}^{20} VL_i} \right)$$

where R_i and L_i (%) are the percentage of volume collected at height i and at each side of the sprayer, right and left, respectively; VR_i and VL_i (mL) are the average spray volume collected at height i and at each side of the sprayer, right and left, respectively; and i is the corresponding patternator tray at height i .

Finally, these percentages were included in a database that is consulted and graphically represented in the tool according to the machine settings input by the user.

3. Results

3.1. Description of the Vertical Spray Profiles

The resulting vertical spray profiles showing the normalized volume collected by the patternator (mL/(100 L/ha)) with each sprayer at different heights above the ground, and for the different nozzle types, fan speeds, volume rates and adjustment to canopy, are shown in Figures 8–10, for the T, C1 and C2 sprayers, respectively. All the profiles were largely symmetrical, with SI ranging between 93 and 98% (Table 4). Nevertheless, the total volume collected on the left side of the sprayers was lower than on the right in most cases. This was more evident in the part of the profile corresponding to the space above the canopy, where higher values were found independently of the sprayer and configuration. This is probably due to the sense of rotation of the fans, which made the airflow, and therefore the spray cloud, be directed upwards in the right side of the sprayer but downwards on the left.

As expected, the adjustment of the nozzles concentrated the spray profile in the canopy zone in all cases, reducing the volume collected in the upper part of the patternator. This effect was more evidenced for the T sprayer, mainly in its left side. In general terms, low fan speed increased the volume collected. Furthermore, low-volume applications tended to increase the normalized volume collected with respect to the high-volume applications. This effect was lower for the C1 sprayer, probably because larger volume rates were impossible to attain due to the low number of nozzles, as stated before. In general, the combination of the high fan speed and the coarse nozzles produced the lowest collected volumes in the canopy zone and the highest ones in the above canopy zones. Such differences were larger in the applications in which nozzles were not adjusted to vegetation and mainly in the C1 and C2 sprayers.

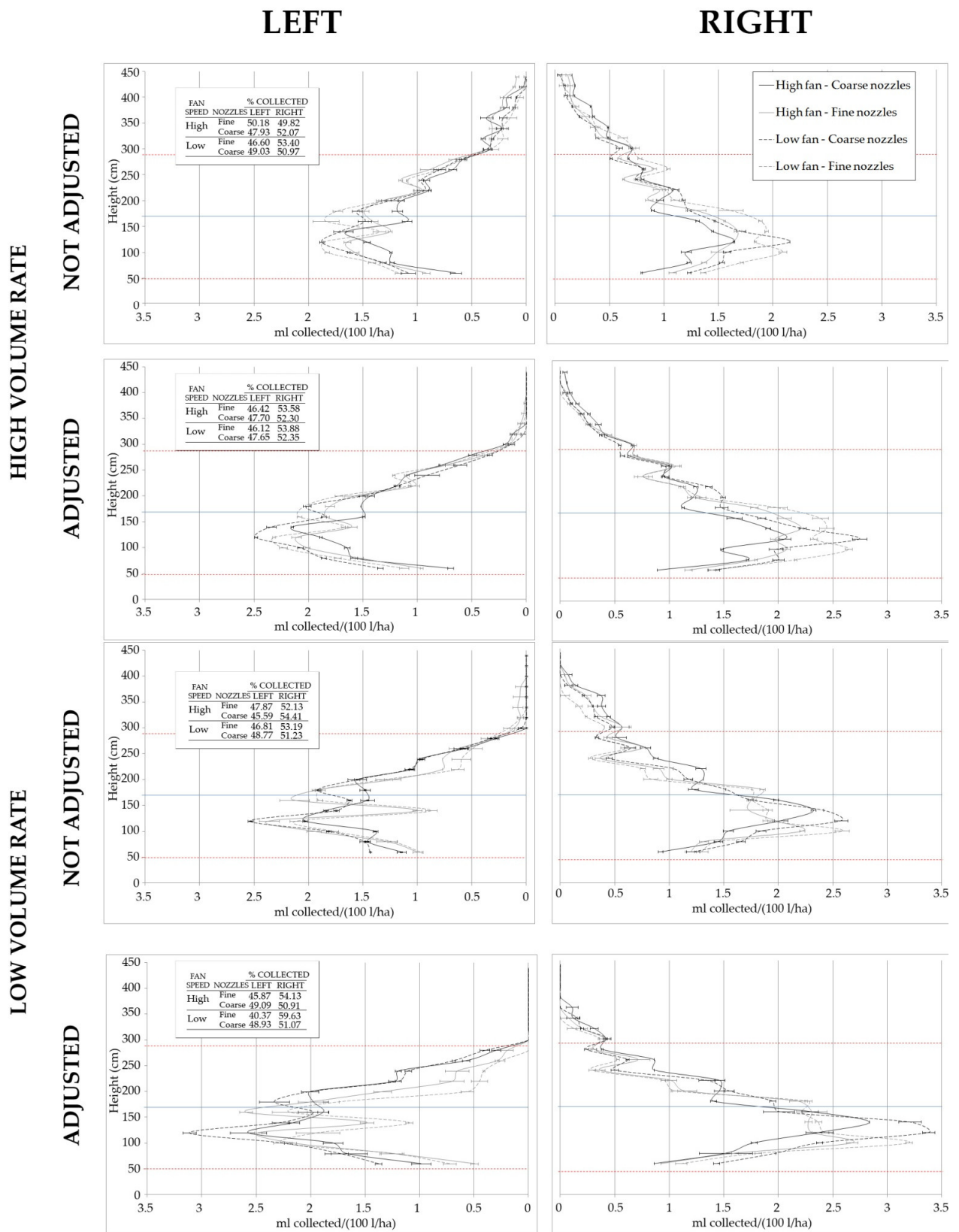

Figure 8. Vertical spray profiles showing the normalized volume collected by the patternator (mL/(100 L/ha) (mean ± Standard error (SE)) at different heights above the ground (m), for the applications with the **T sprayer**. The percentage collected on each side of the sprayer respect to the total volume collected for each configuration is shown. The red dashed lines represent the upper and the lower limit of the canopy target, and the blue line its middle height.

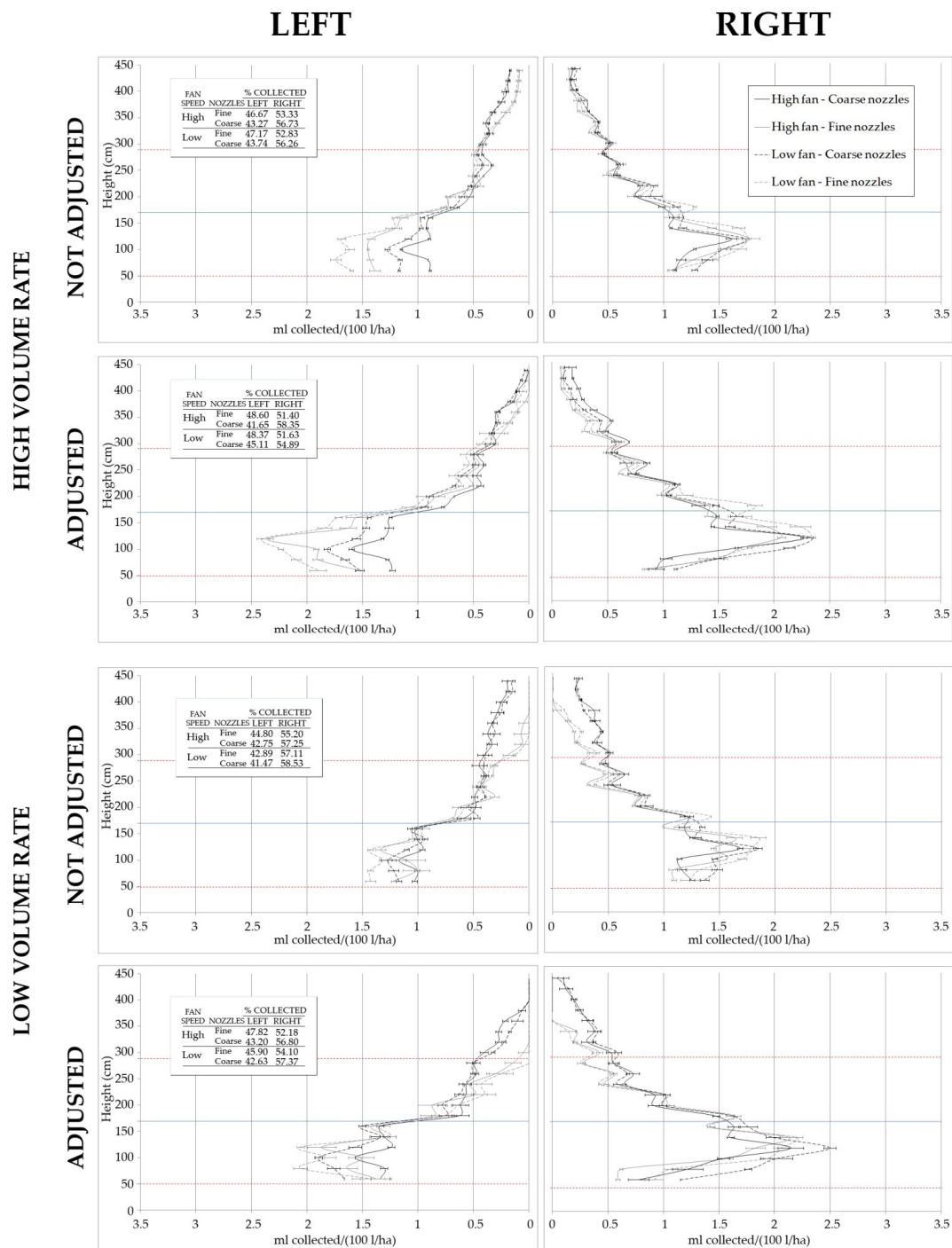

Figure 9. Vertical spray profiles showing the normalized volume collected by the patternator (mL/(100 L/ha) (mean ± SE) at different heights above the ground (m), for the applications with the **C1 sprayer**. The percentage collected on each side of the sprayer respect to the total volume collected for each configuration is shown. The red dashed lines represent the upper and the lower limit of the canopy, and the blue line its middle height.

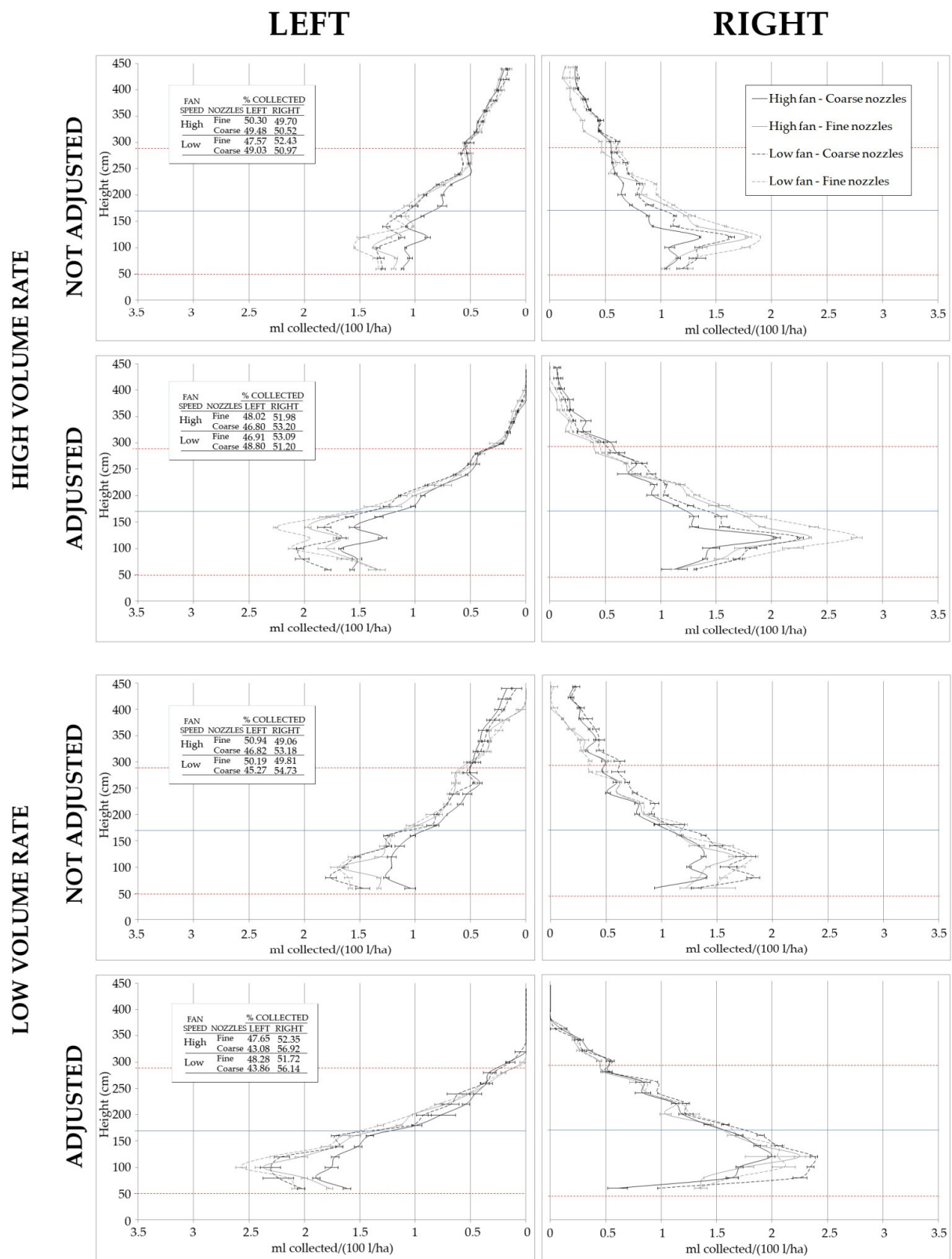

Figure 10. Vertical spray profiles showing the normalized volume collected by the patternator (mL/(100 L/ha) (mean ± SE) at different heights above the ground (m), for the applications with the **C2 sprayer**. The percentage collected on each side of the sprayer respect to the total volume collected for each configuration is shown. The red dashed lines represent the upper and the lower limit of the canopy, and the blue line its middle height.

Table 4. SI (%) between the sprayers' sides for the vertical spray profiles of each sprayer and each configuration.

Volume Rate	Adjustment	Fan speed	Nozzle Type	Sprayer		
				C1	C2	T
High	Adjusted	High	Fine	96.02	97.09	96.70
			Coarse	94.58	96.00	97.05
		Low	Fine	95.32	97.27	96.43
			Coarse	96.22	96.87	97.43
	Not Adjusted	High	Fine	97.09	97.31	97.08
			Coarse	95.86	97.93	97.41
		Low	Fine	96.51	97.64	97.03
			Coarse	96.22	97.97	98.05
Low	Adjusted	High	Fine	92.82	95.68	95.90
			Coarse	94.59	94.44	96.33
		Low	Fine	92.94	95.76	93.49
			Coarse	94.86	95.31	96.57
	Not Adjusted	High	Fine	95.19	98.11	96.15
			Coarse	95.57	98.23	96.11
		Low	Fine	94.04	98.00	94.91
			Coarse	95.12	98.08	96.47

3.2. Factors Affecting the Vertical Spray Profile

3.2.1. T Sprayer

Normalized Volume Collected in the Canopy Zone with the T Sprayer

The normalized volume collected in the canopy zone with the T sprayer ranged between 12.03 and 21.25 mL/(100 L/ha), with an average value of 16.51 (standard error = 0.22). The results of the multifactor ANOVA for the canopy zone with the T sprayer showed that all the interactions were significant (Table 5).

Table 5. Two-way ANOVA results for the normalized volume collected in the canopy zone with the T sprayer (least significant difference (LSD) test, $p < 0.05$)^a.

	<i>df</i>	<i>F</i>	<i>P</i>
MAIN EFFECTS			
Adjustment	1, 95	132.31	<0.001 *
Nozzle	1, 95	4.54	0.036 *
Fan speed	1, 95	39.57	<0.001 *
Volume	1, 95	4.49	0.037 *
INTERACTIONS			
Adjustment * Nozzle	1, 95	7.24	0.009
Adjustment * Fan speed	NS	NS	NS
Adjustment * Volume	1, 95	4.75	0.032
Nozzle * Fan speed	1, 95	11.49	0.001
Nozzle * Volume	1, 95	55.14	<0.001
Fan speed * Volume	1, 95	19.15	<0.001

* These factors were not considered/interpreted, since interactions of higher order in which they took part were significant at $p < 0.05$. ^a Non-significant factors/interactions are presented as 'NS'.

The nozzle adjustment to the vegetation with the T sprayer increased the volume collected in the canopy zone in all cases. The increase was larger for coarse than for fine nozzles such that, while there were no differences between the two nozzle types when the nozzles were not adjusted to vegetation, higher volumes were collected when coarse nozzles were adjusted to vegetation (Figure 11). In addition, while low-volume applications collected higher volumes when nozzles were not adjusted, the difference disappeared when nozzles were adjusted (Figure 12).

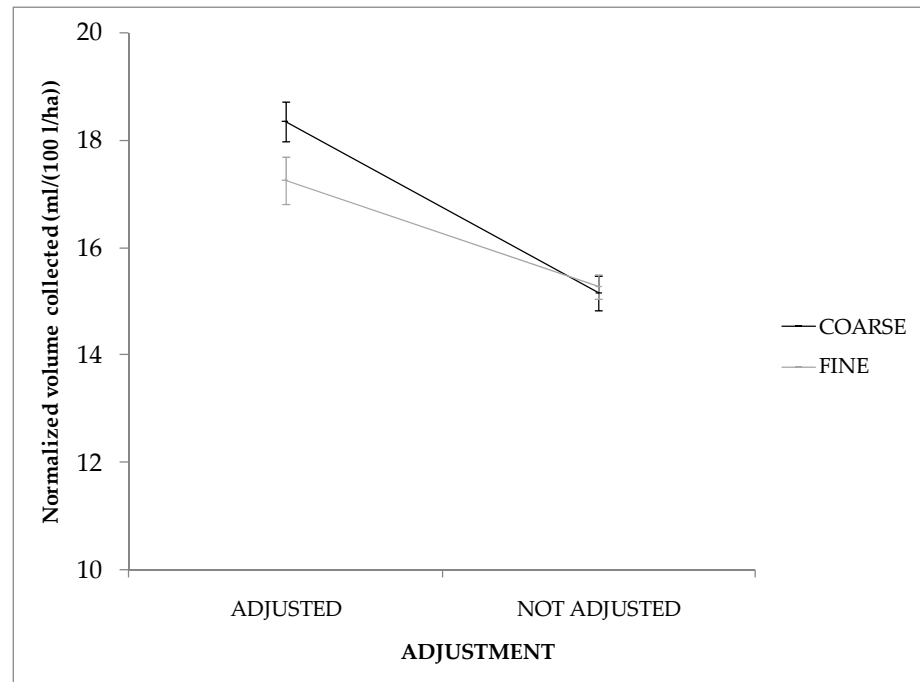

Figure 11. Adjustment \times Nozzle type interaction effect on the normalized volume collected in the canopy zone (mean \pm SE) with the T sprayer.

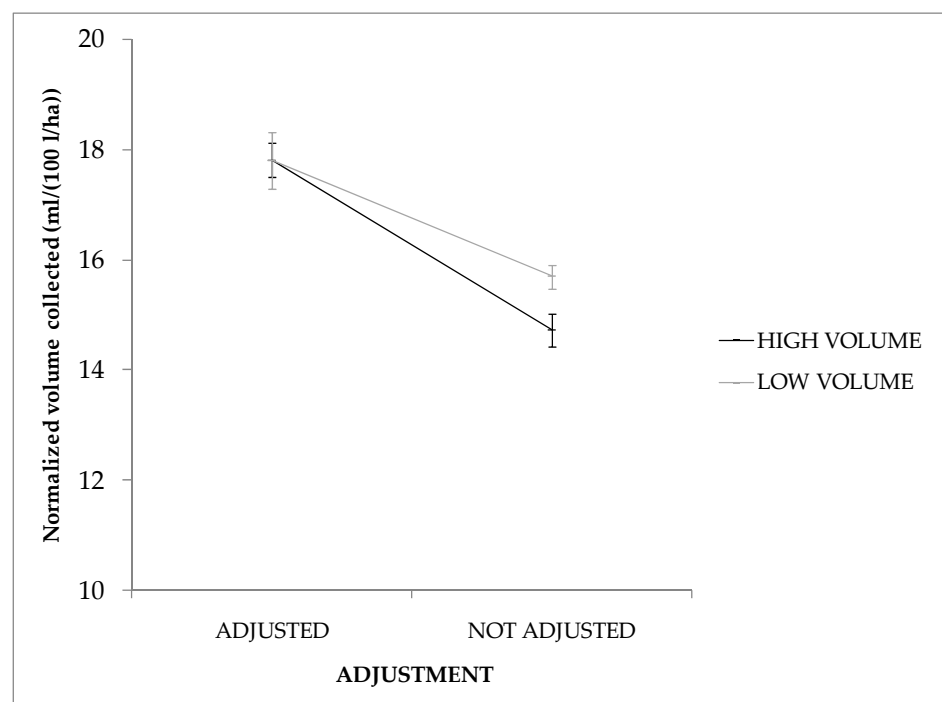

Figure 12. Adjustment \times Volume rate interaction effect on the normalized volume collected in the canopy zone (mean \pm SE) with the T sprayer.

Regarding the effect of the fan speed in the T sprayer, the use of the low fan speed increased the volume collected in the canopy zone. This effect was different for each type of nozzle, being higher for the coarse nozzles than for the fine ones (Figure 13).

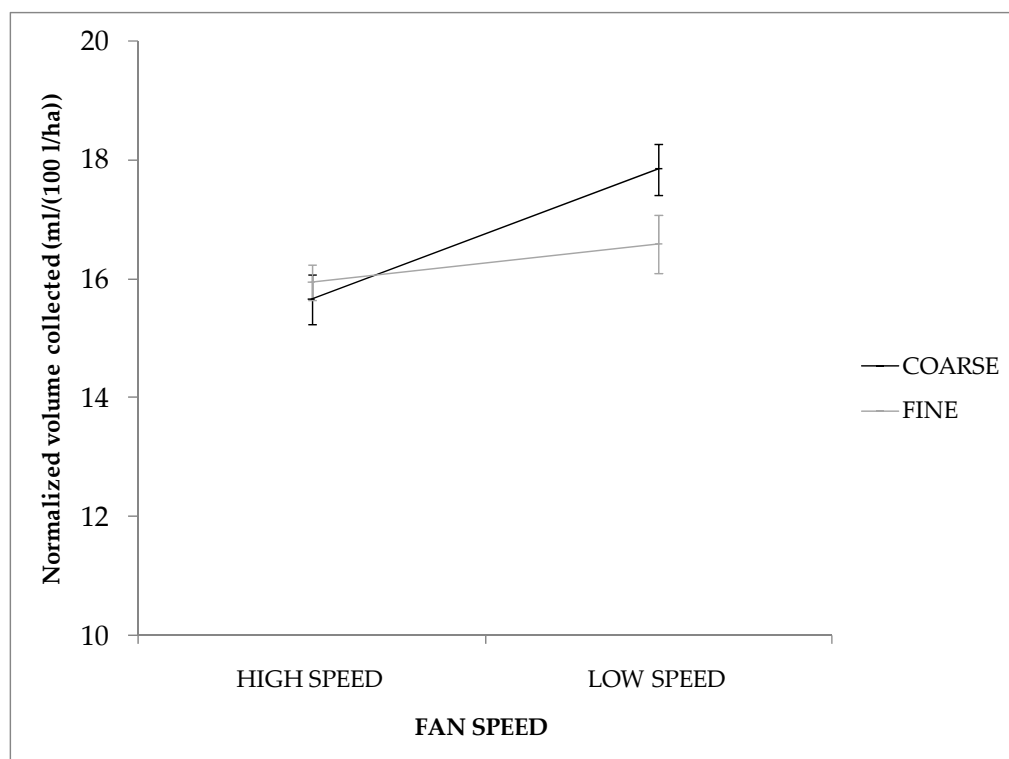

Figure 13. Nozzle type \times Fan speed interaction effect on the normalized volume collected in the canopy zone (mean \pm SE) with the T sprayer.

Normalized Volume Collected above the Canopy Zone with the T Sprayer

The normalized volume collected in collectors corresponding to the zone above the canopy ranged between 0.00 and 3.20 mL/(100 L/ha), with an average value of 1.03 (standard error = 0.09). ANOVA showed that the nozzle type did not have a significant effect on the volume collected. However, the other factors had significant simple and interaction effects (Table 6).

Table 6. Two-way ANOVA results for the normalized volume collected above the Canopy height with the T sprayer (least significant difference (LSD) test, $p < 0.05$)^a.

	<i>df</i>	<i>F</i>	<i>p</i>
MAIN EFFECTS			
Adjustment	1, 95	29.67	<0.001 *
Nozzle	NS	NS	NS
Fan speed	1, 95	5.04	0.027
Volume	1, 95	48.47	<0.001 *
INTERACTIONS			
Adjustment * Nozzle	NS	NS	NS
Adjustment * Fan speed	NS	NS	NS
Adjustment * Volume	1, 95	4.31	0.041
Nozzle * Fan speed	NS	NS	NS
Nozzle * Volume	NS	NS	NS
Fan speed * Volume	NS	NS	NS

* These factors were not considered/interpreted, since interactions of higher order in which they took part were significant at $p < 0.05$. ^a Non-significant factors/interactions are presented as 'NS'.

The normalized volume collected significantly increased at high fan speed, despite the combination of the other factors (Figure 14). As expected, nozzle adjustment to the canopy decreased the volume collected. Such reduction was higher at high than at low-volume rates (Figure 15).

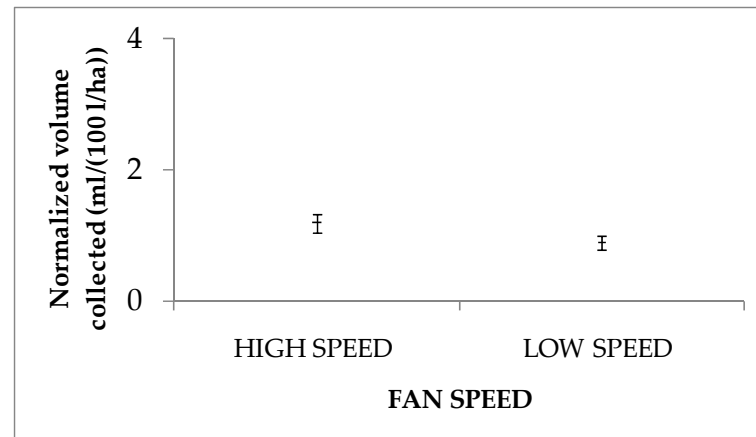

Figure 14. Fan speed effect on the normalized volume collected above the Canopy height (mean \pm SE) with the T sprayer.

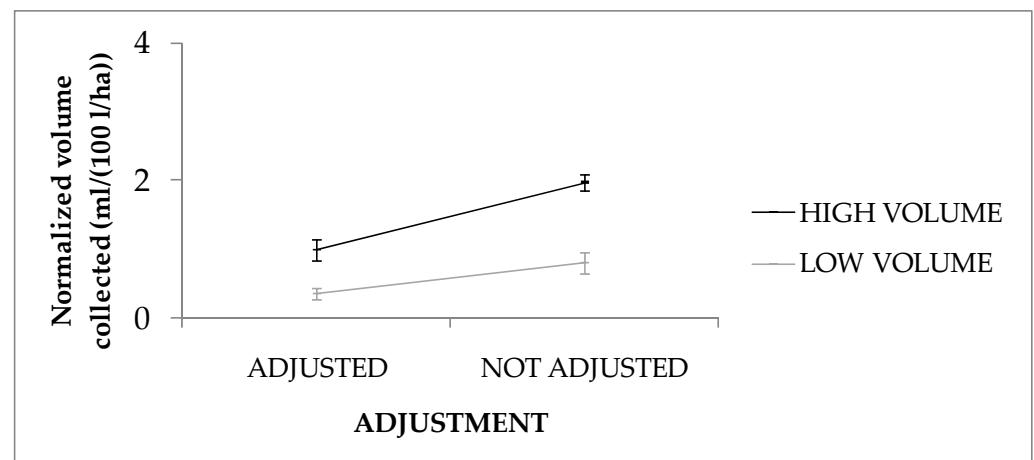

Figure 15. Volume rate \times Adjustment interaction effect on the normalized volume collected above the Canopy height (mean \pm SE) with the T sprayer.

3.2.2. C1 Sprayer

Normalized Volume Collected in the Canopy Zone with the C1 Sprayer

The normalized volume collected in the canopy zone with the C1 sprayer ranged between 8.26 and 17.26 mL/(100 L/ha), with an average value of 12.69 (standard error = 0.23).

Multifactor ANOVA at the canopy zone with the C1 sprayer (Table 7) showed that the use of the low fan speed significantly increased the volume collected in the canopy zone (Figure 16), as well as the nozzle adjustment to the canopy (Figure 17). The effect of the volume rate was different depending on the nozzle type. While the volume collected rose with the increase of volume rate when fine nozzles were used, it did not rise with the coarse nozzles. Furthermore, a lower volume was collected with the coarse than with the fine nozzles when spraying at a high volume rate. No differences between nozzle types were observed when applying low volume rates (Figure 18).

Table 7. Two-way ANOVA results for the normalized volume collected in the canopy zone with the C1 sprayer (least significant difference (LSD) test, $p < 0.05$)^a.

	<i>df</i>	<i>F</i>	<i>p</i>
MAIN EFFECTS			
Adjustment	1, 95	98.31	<0.001
Nozzle	1, 95	6.77	0.011 *
Fan speed	1, 95	24.66	<0.001
Volume	1, 95	8.23	0.005 *
INTERACTIONS			
Adjustment * Nozzle	NS	NS	NS
Adjustment * Fan speed	NS	NS	NS
Adjustment * Volume	NS	NS	NS
Nozzle * Fan speed	NS	NS	NS
Nozzle * Volume	1, 95	13.26	<0.001
Fan speed * Volume	NS	NS	NS

* These factors were not considered/interpreted, since interactions of higher order in which they took part were significant at $p < 0.05$. ^a Non-significant factors/interactions are presented as 'NS'.

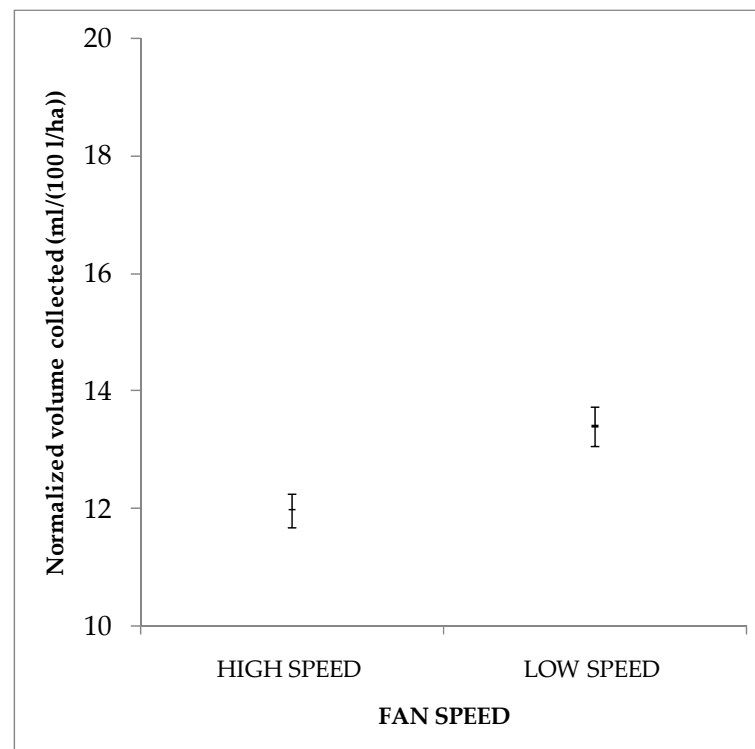
**Figure 16.** Fan speed effect on the normalized volume collected in the canopy zone (mean \pm SE) with the C1 sprayer.

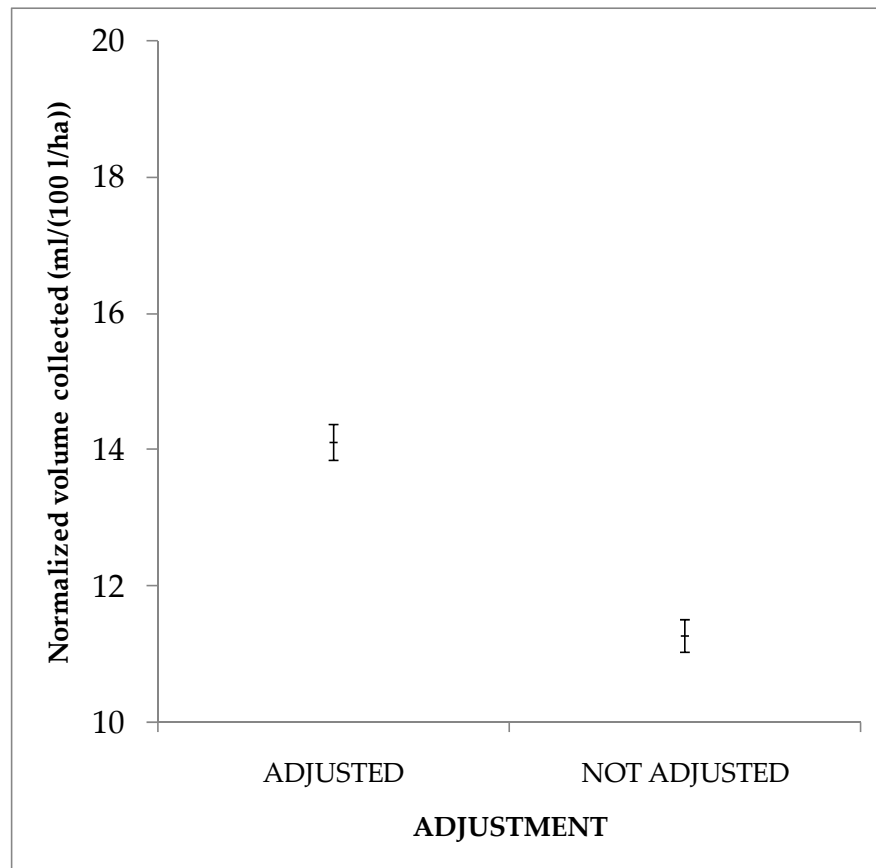

Figure 17. Adjustment effect on the normalized volume collected in the canopy zone (mean \pm SE) with the C1 sprayer.

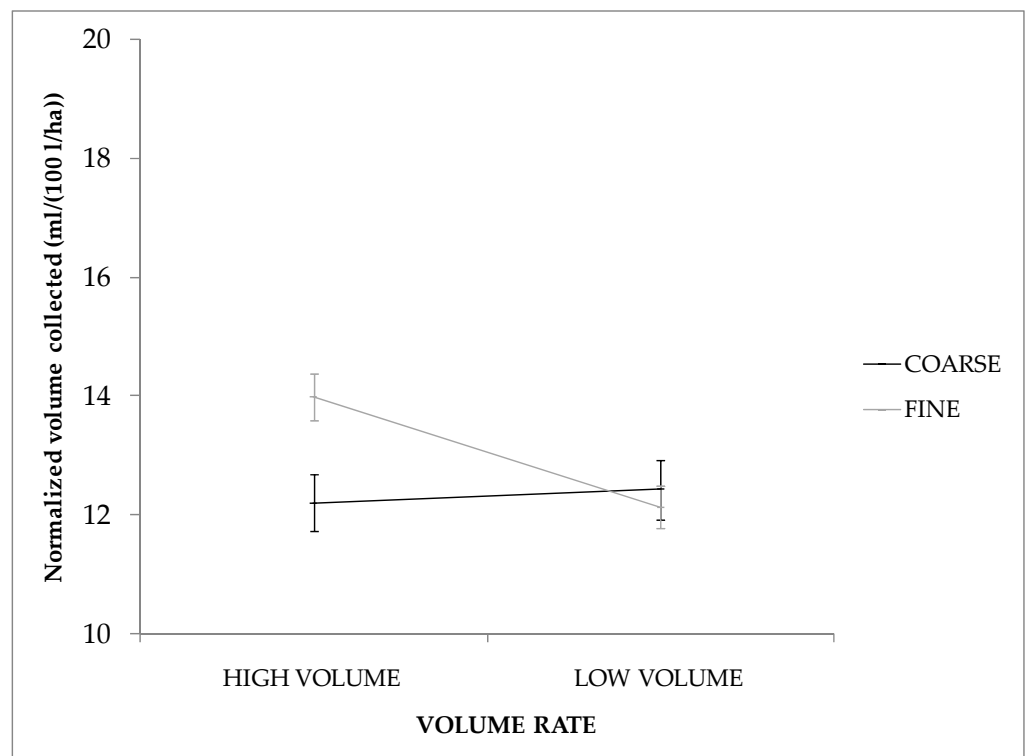

Figure 18. Volume rate \times Nozzle type interaction effect on the normalized volume collected in the canopy zone (mean \pm SE) with the C1 sprayer.

Normalized Volume Collected above the Canopy with the C1 Sprayer

The normalized volume collected above the Canopy height with the C1 sprayer ranged between 0.00 and 3.23 mL/(100 L/ha), with an average value of 1.65 (standard error = 0.09).

Multifactor ANOVA showed that the different fan speeds did not have a significant effect on the volume collected (Table 8). Nozzle adjustment decreased it (Figure 19). As in the canopy zone, the effect of the volume rate depended on the nozzle type and had a similar trend: the volume collected increased with the volume rate when fine nozzles were used, but it did not significantly change when coarse nozzles were used. However, higher volume was collected with the coarse nozzles at the two volume rates (Figure 20).

Table 8. Two-way ANOVA results for the normalized volume collected above the Canopy height with the C1 sprayer (least significant difference (LSD) test, $p < 0.05$)^a.

	<i>df</i>	<i>F</i>	<i>p</i>
MAIN EFFECTS			
Adjustment	1, 95	21.55	<0.001
Nozzle	1, 95	108.37	<0.001 *
Fan speed	NS	NS	NS
Volume	1, 95	50.97	<0.001 *
INTERACTIONS			
Adjustment * Nozzle	NS	NS	NS
Adjustment * Fan speed	NS	NS	NS
Adjustment * Volume	NS	NS	NS
Nozzle * Fan speed	NS	NS	NS
Nozzle * Volume	1, 95	27.88	<0.001
Fan speed * Volume	NS	NS	NS

* These factors were not considered/interpreted, since interactions of higher order in which they took part were significant at $p < 0.05$. ^a Non-significant factors/interactions are presented as 'NS'.

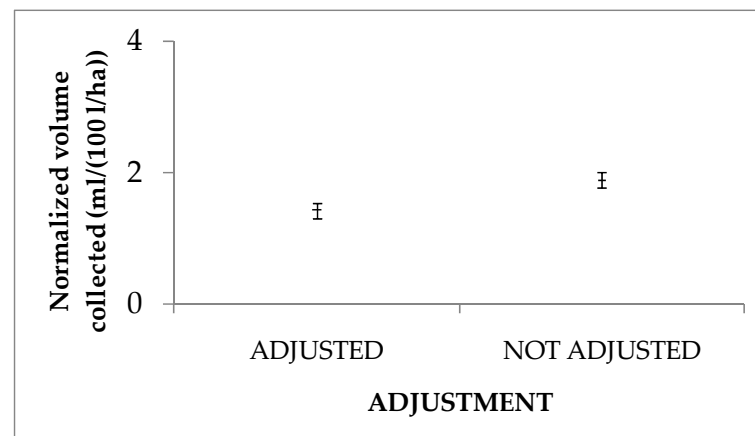

Figure 19. Adjustment effect on the normalized volume collected above the Canopy height (mean \pm SE) with the C1 sprayer.

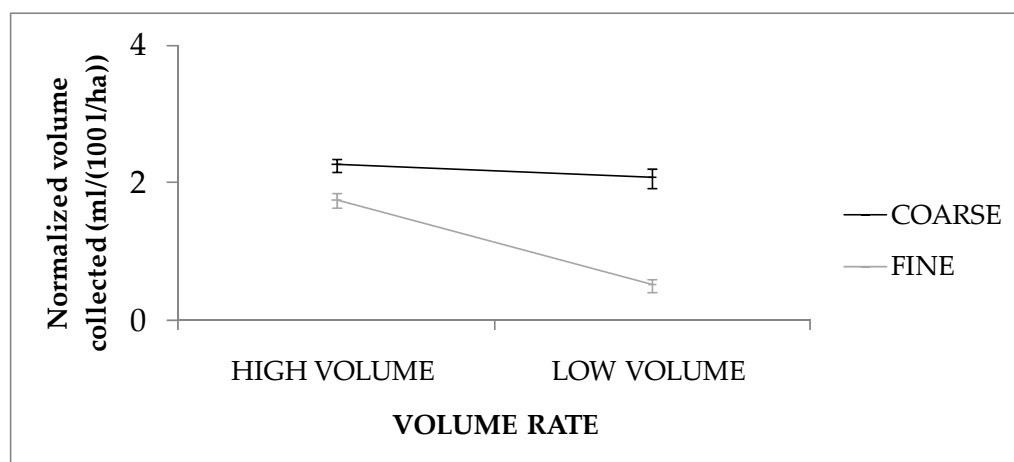

Figure 20. Volume rate \times Nozzle type interaction effect on the normalized volume collected above the Canopy height (mean \pm SE) with the C1 sprayer.

3.2.3. C2 Sprayer

Normalized Volume Collected in the Canopy Zone with the C2 Sprayer

The normalized volume collected in the canopy zone with the C2 sprayer ranged between 9.80 and 16.47 mL/(100 L/ha), with an average value of 14.01 (standard error = 0.23).

Multifactor ANOVA showed, on the one hand, that nozzle adjustment accounted for the highest part of the data variability. This effect was the same despite the combination of the other factors (Table 9). Such adjustment increased the volume collected in all cases (Figure 21). On the other hand, the effect of the nozzle type depended on the fan speed and the volume rate. The reduction of the fan speed increased the volume collected with both types of nozzles, but the effect was more evident for the coarse than for the fine nozzles (Figure 22). Something similar was observed with the volume rate, whose reduction tended to increase the volume collected, but this increase was higher with the coarse than with the fine nozzles (Figure 23).

Table 9. Two-way ANOVA results for the normalized volume collected in the canopy zone with the C2 sprayer (least significant difference (LSD) test, $p < 0.05$)^a.

	<i>df</i>	<i>F</i>	<i>p</i>
MAIN EFFECTS			
Adjustment	1, 95	497.22	<0.001
Nozzle	1, 95	49.09	<0.001 *
Fan speed	1, 95	156.63	<0.001 *
Volume	1, 95	22.82	<0.001 *
INTERACTIONS			
Adjustment * Nozzle	NS	NS	NS
Adjustment * Fan speed	NS	NS	NS
Adjustment * Volume	NS	NS	NS
Nozzle * Fan speed	1, 95	11.182	0.001
Nozzle * Volume	1, 95	9.117	0.003
Fan speed * Volume	NS	NS	NS

* These factors were not considered/interpreted, since interactions of higher order in which they took part were significant at $p < 0.05$. ^a Non-significant factors/interactions are presented as 'NS'.

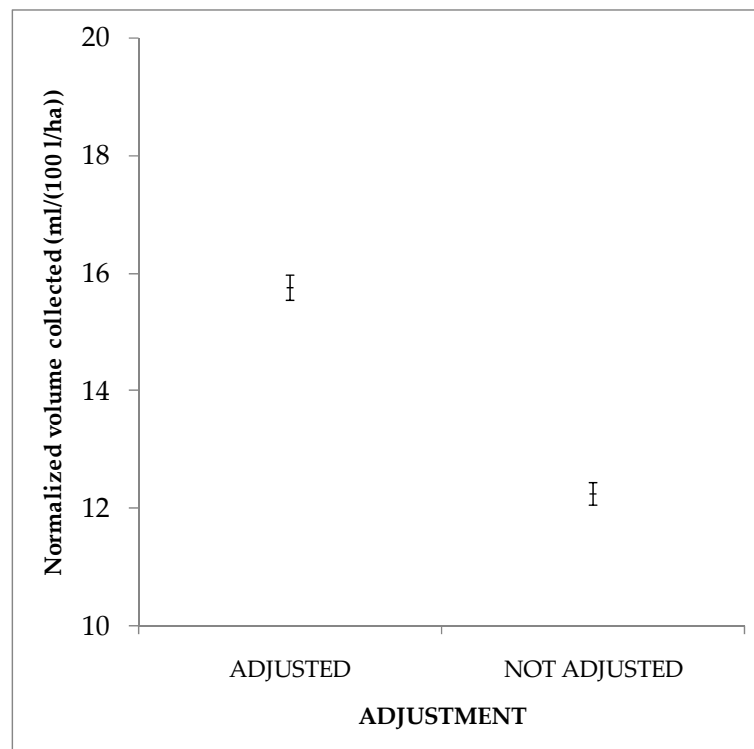

Figure 21. Adjustment effect on the normalized volume collected in the canopy zone (mean \pm SE) with the C2 sprayer.

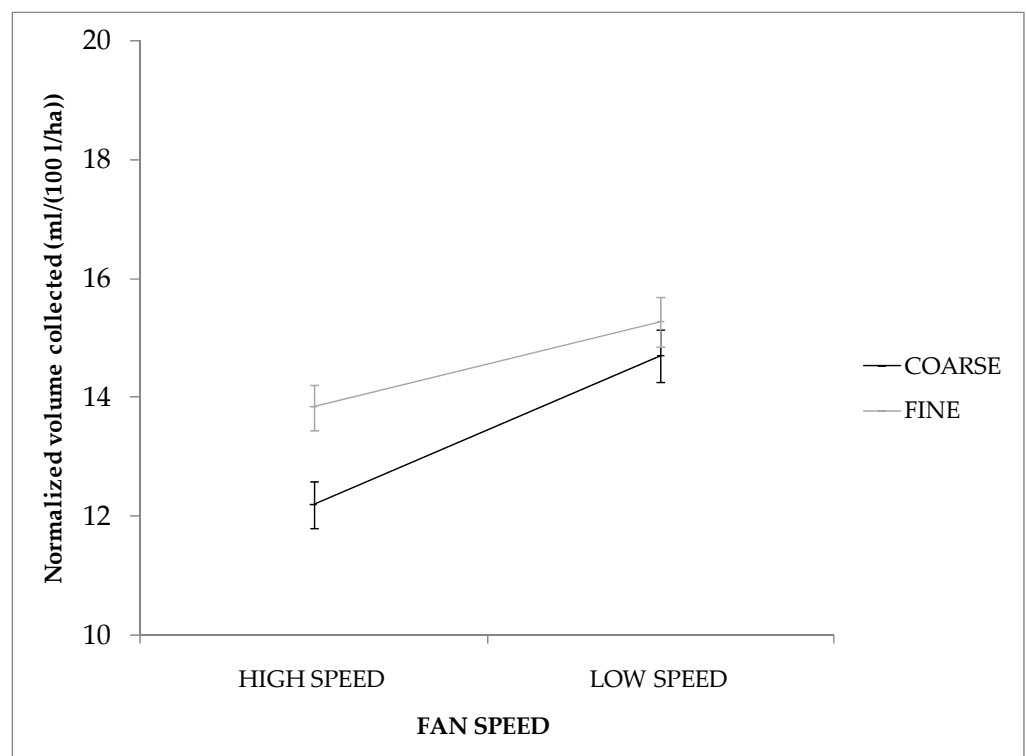

Figure 22. Nozzle type \times Fan speed interaction effect on the normalized volume collected in the canopy zone (mean \pm SE) with the C2 sprayer.

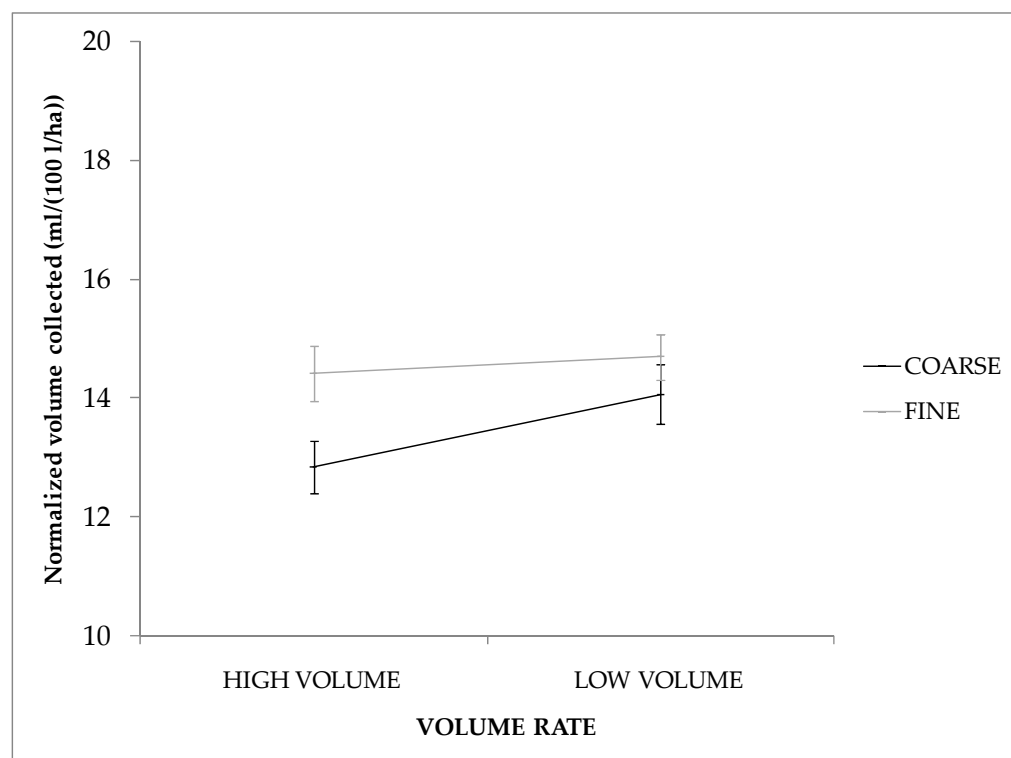

Figure 23. Nozzle type x Volume rate interaction effect on the normalized volume collected in the canopy zone (mean \pm SE) with the C2 sprayer.

Normalized Volume Collected above the Canopy with the C2 Sprayer

The normalized volume collected above the Canopy height with the C2 sprayer ranged between 0.00 and 3.37 mL/(100 L/ha), with an average value of 1.57 (standard error = 0.10).

As was observed in the C1 sprayer, the different fan speeds did not have a significant effect on the volume collected (Table 10). Moreover, the higher the volume rate applied, the higher the volume collected (Figure 24). The adjustment of the nozzles to the vegetation reduced the amount of volume collected, with higher reduction with Coarse than with Fine nozzles. However, the volume collected with non-adjusted Coarse nozzles was higher than with Fine nozzles. Significant differences between nozzle types disappeared when the nozzle booms were adjusted (Figure 25).

Table 10. Two-way ANOVA results for the normalized volume collected above the Canopy height with the C2 sprayer (least significant difference (LSD) test, $p < 0.05$)^a.

	<i>df</i>	<i>F</i>	<i>p</i>
MAIN EFFECTS			
Adjustment	1, 95	290.10	<0.001 *
Nozzle	1, 95	25.73	<0.001 *
Fan speed	NS	NS	NS
Volume	1, 95	26.06	<0.001
INTERACTIONS			
Adjustment * Nozzle	1, 95	7.51	0.007
Adjustment * Fan speed	NS	NS	NS
Adjustment * Volume	NS	NS	NS
Nozzle * Fan speed	NS	NS	NS
Nozzle * Volume	NS	NS	NS
Fan speed * Volume	NS	NS	NS

* These factors were not considered/interpreted, since interactions of higher order in which they took part were significant at $p < 0.05$. ^a Non-significant factors/interactions are presented as 'NS'.

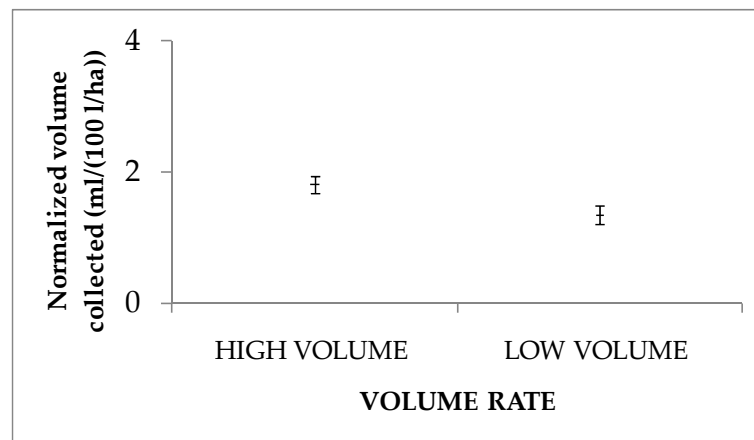

Figure 24. Volume rate effect on the normalized volume collected above the Canopy height (mean \pm SE) with the C2 sprayer.

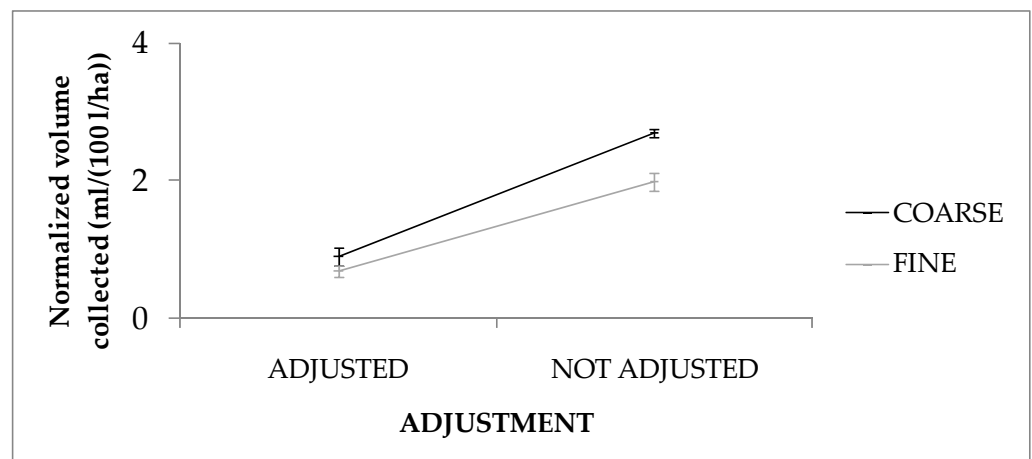

Figure 25. Adjustment \times Nozzle type interaction effect on the normalized volume collected above the Canopy height (mean \pm SE) with the C2 sprayer.

3.3. The CitrusVESPA Tool

Variation coefficients between replicates at each height on each side of each combination sprayer-configuration were mostly lower than 30%. Cases with CV higher than 30% only corresponded to some of the highest patternator collectors. These had low average volume collected and they are more prone to be influenced by the airflow turbulence, which increased data variability and consequently CV.

For this reason, the average of the percentage of spray volume collected at each height and at each side of the sprayer with respect to the total spray volume collected was considered to be representative of the vertical profiles. Data corresponding to the zone above the canopy were assimilated to potential drift, thus providing the means to raise human and environmental risk awareness. The resulting database is the core of the Citrus VESPA tool.

The application has been designed, developed and uploaded on the web by a software company (Tredoppiavù di Rastaldo Marco, Rosta—Torino, Italy) under the supervision of IVIA and DiSAFA.

The Citrus VESPA tool is freely available in three languages—Spanish, English and Italian—and is hosted at the URL <https://www.laboratorio-cpt.to.it/citrus-vertical-spray-pattern/?lang=en> (accessed on 10 June 2022). The tool is very intuitive in order to ensure

ease of use for various potential users. At the bottom of the initial screen, the parameters required to obtain a vertical spray profile are displayed. Each parameter refers to one of the factors studied in this article. Tabs are displayed for each parameter in order for the user to choose between the following options and generate a query to the database.

- Type of sprayer:
 - Conventional with axial fan (which refers the C sprayer data).
 - Triangular tower with axial fan (which refers to the T sprayer data).

In order to help the user select the type of equipment, different pictures of sprayers are provided as examples.

- Number of boom nozzles per side of the equipment. If the user selects the triangular tower sprayer, only 1 boom nozzle can be selected. If the user selects a conventional sprayer, there are two options:
 - 1 boom nozzle (which refers to the C1 sprayer data).
 - 2 boom nozzles (which refers to the C2 sprayer data).
- Nozzle configuration:
 - Adjusted to the vegetation
 - Not adjusted to the vegetation

In order to clarify what this means, the following explanation appears on the screen: “Indicate if all the nozzles of the sprayer are open, regardless of the profile of the target crop (option = not adjusted to the target) or if the nozzles open are only those necessary so that the spray cloud matches the profile of the target crop (option = adjusted to target)”.

- Type of nozzles:
 - Conventional hollow cone nozzles (which refers to the fine nozzle data).
 - Antidrift air induction hollow cone nozzles (which refers to the coarse nozzle data).
- Fan airflow rate:
 - High.
 - Low.

The following explanation is given: “High” refers to the high-speed gearbox of the fan, and “Low” refers to the low-speed gearbox of the fan.

- Volume application rate:
 - >2000 L/ha (which refers to the high-volume rate data).
 - <2000 L/ha (which refers to the low-volume rate data).

A calculator to determine the spray volume (L/ha) applied by the sprayer is included at the top of the initial screen. It calculates this volume based on the flow rate of the sprayer (L/min), the row spacing in the orchard (m) and the forward speed of the tractor (km/h).

An example to show the outputs of the tool was performed, selecting the following options:

- Type of sprayer: Triangular deflector axial fan with 1 boom nozzle
- Type of nozzles: Antidrift
- Fan airflow rate: Low fan speed
- Volume of application: >2000 L/ha,
- Nozzle configuration: To show the effect of nozzle adjustment, the two options have been tested (adjusted to the vegetation and not adjusted).

Results are shown in Figure 26. A slight asymmetry in the profile between the sides of the sprayer is depicted. Figures of the predictable deposition in the canopy and the potential drift are shown. The importance of adjusting the nozzles to the vegetation can be easily observed because a reduction of potential losses over the canopy and an increase in the spray deposited in the vegetation is expected.

Sprayer type: Conventional triangular air conveyor axial fan

Nozzle type: Antidrift air induction hollow cone Albus TVI 80

Number of spray booms per machine side: 1

Fan air flow rate: Low

Nozzle configuration: Adjusted to target

Volume application rate: >2000 L/ha

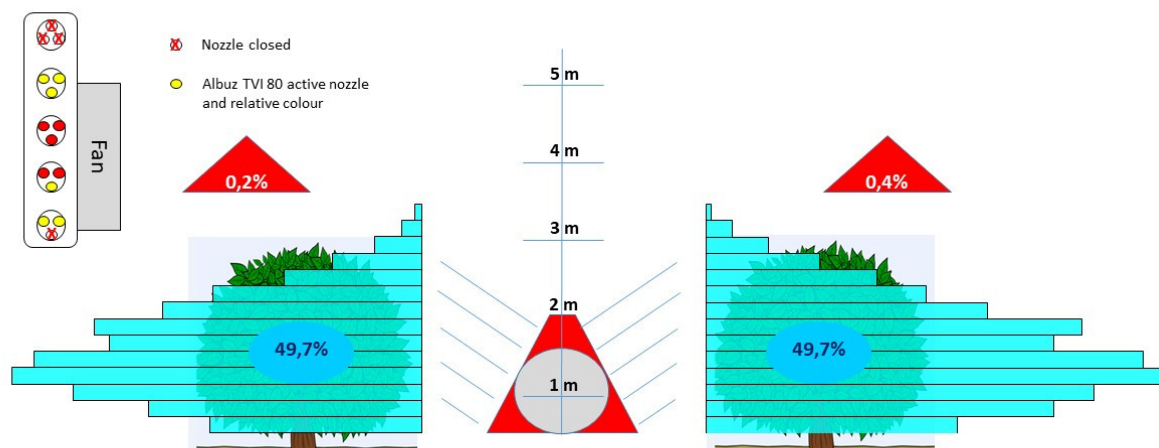

In the graphic it is reported the shape of the vertical spray pattern on the two machine sides with the indication of the repartition of the liquid (expressed in percentage) on the target (figures in the ovals) and over the target (figures in the triangles).

Sprayer type: Conventional triangular air conveyor axial fan

Nozzle type: Antidrift air induction hollow cone Albus TVI 80

Number of spray booms per machine side: 1

Fan air flow rate: Low

Nozzle configuration: Not adjusted

Volume application rate: >2000 L/ha

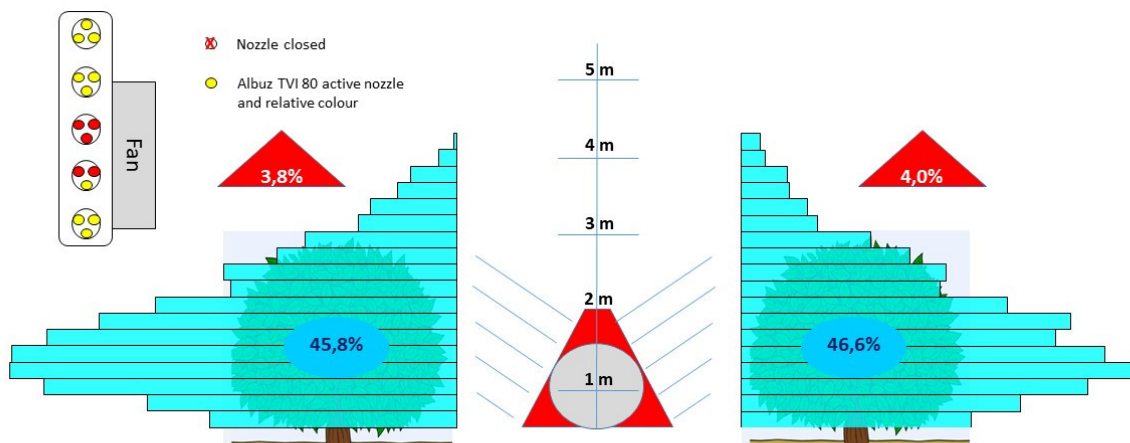

In the graphic it is reported the shape of the vertical spray pattern on the two machine sides with the indication of the repartition of the liquid (expressed in percentage) on the target (figures in the ovals) and over the target (figures in the triangles).

Figure 26. Citrus VESPA output for the example. Top image: Triangular outlet fan, 1 boom sprayer, Antidrift nozzles, low fan speed, ADJUSTED nozzle configuration and spray volume rate >2000 L/ha; Bottom image: Triangular outlet fan, 1 boom sprayer, Antidrift nozzles, low fan speed, NOT ADJUSTED nozzle configuration and spray volume rate >2000 L/ha.

4. Discussion

Matching sprayer parameters (airspeed, direction of airflow, spray volume rate, droplet spectra and application speed) to tree size, shape and density will reduce spray drift of air-blast sprayers [70]. Our experiments showed that all the tested sprayers (C1,

C2 and T) strongly reduced the liquid sprayed above the standard citrus canopy (2.90 m height) when nozzle openings were adjusted to the target, irrespective of nozzle type (coarse or fine), spray volume rate (high or low) and fan gearbox speed (high or low) settings. This finding was of prime interest considering that most spray drift in orchard treatments involves droplets that move above the canopy, especially via direct spraying into the air [6,71,72]. Minimizing the spray cloud above the targeted canopy by matching its shape and height will enhance the chances of reducing spray drift during application.

Interestingly, the correct adjustment of sprayers increased the spray efficiency by reducing the spray liquid potentially lost above the canopy and increasing the liquid collected in the canopy zone. This is consistent with the results recently obtained by Grella et al. [7], who evaluated the efficiency of airblast sprayers for vineyards under field conditions using a mass-balance approach. The authors reported that the technical features of the sprayers and their proper adjustment can enhance the canopy spray deposition, thus substantially reducing off-target losses and contributing to the efficiency increase of spray application.

While the selection of the appropriate active nozzles showed clear benefits, the significance of the other tested factors and their interactions depended on the sprayer type. The spray volume rate had in all cases a significant effect on the liquid collected by the patternator, in most cases in interaction with other parameters—for example, the nozzle adjustment to the canopy or the nozzle type. In general, the higher the volume, the lower the volume collected in the canopy zone and the higher the volume collected above the canopy, thus indicating that the application of a higher volume rate may decrease efficiency, which is in line with the results of other authors, who found that lower spray volumes increased the amount of normalized target deposition and the application efficiency [73–77].

In general, figures obtained in the tests indicated that the amount of liquid directed to the canopy zone decreased significantly when using a high fan speed. However, in most cases, the fan speed showed significant interactions with the nozzle type without a clear tendency. Contrarily, regarding the liquid collected above the canopy zone, in general the fan speed setting did not show significant effects, while the nozzles producing coarse droplets significantly increased the liquid collected at the upper part of the patternator. This trend for the top height was especially clear for the C1 and C2 sprayer, while the T sprayer showed no significant effect of the nozzle type. Results were fully in line with those obtained by Grella et al. [24,78], who combined low and high fan speeds with conventional and air induction nozzles in an airblast sprayer typically used in vineyards, applying the same volume rate in all cases. In these tests, the increased fan speed augmented the spray drift, because the ability of canopies to trap droplets is reduced due to excessive canopy air compression. The same effect was observed for both nozzle types, although spray drift reduction was higher for the air induction nozzles as the size of the particles has a large impact on the off-target drift [79], higher than the environmental wind speed during the spray drift generation process [24,80,81]. Nevertheless, the influence of fan speed also depends on the sprayer design. Li et al. [82] tested a multi-fan sprayer and found that the increased airflow speed increased deposition on the abaxial side of leaves, but it did not improve deposition on the adaxial side, nor the penetration in the canopy.

Drawing conclusions about canopy deposition for the different nozzle types from the results is difficult because the capacity for retaining the sprayed volume of vertical test benches equipped with discrete passive collectors depends on the droplets' size and the air flow rate [58,64,83,84]. In general terms, the coarser the droplets, the higher the liquid collection efficiency, which allows for better discrimination of the effect of the air flow and of the adjustment of the number of active nozzles. This effect was further underlined by the results above the Canopy height, where the patternator trays were far away from the spray and fan airflow sources, thus resulting in higher kinetic energy of coarse droplets, which is more important to reach the patternator than the air assistance setting at farther positions. Furthermore, the patternator was located at 0.75 m from the fan, but the middle

of the canopy would be at 2.25 m, a distance at which the effect of the air assistance would be even lower because there is an abrupt decrease in air speed at points far from the outlet [35]. This, together with the fact that coarser droplets exhibit ballistic behavior [85], means that most of the volume collected with the coarse nozzles in the upper part of the patternator will likely be deposited in the canopy or on the ground close to the sprayer and the target [6,86–88]. On the other hand, finer droplets are more susceptible to low air speeds and therefore are more prone to drift [89], so the volume collected with the fine nozzles above the canopy zone will be expectedly lost as drift. In any case, the spray liquid distribution is directly linked to the generated airflow pattern and the airflow characteristics [34,38]; therefore, an overall optimization of spray and airflow patterns generated by the airblast sprayers must be considered concurrently. To date, vertical patternators with discrete trays allow a proper estimation of liquid spray patterns [36,61,89–92] despite the noted limitations and with the adequate analysis of data relating the vertical profile and distribution in the canopy.

Precisely considering that factors interact and behave differently for each type of sprayer, the Citrus VESPA web-tool constitutes a good opportunity for farmers to check how the vertical spray profile changes by varying the sprayer parameters. Even if the number of sprayer models and configurations which were tested to create the Citrus VESPA database was relatively limited, it was nevertheless enough to identify that the number and position of the active nozzles on the sprayer is crucial for tailoring the spray profile. Data demonstrated how the proper selection of the number and position of activated nozzles plays a key role in matching the canopy target height, thus preventing most losses due to spray liquid addressed over or under the target. As the purpose of the Citrus VESPA tool is to provide basic indications to farmers and sprayer users for the correct adjustment of their machines rather than to precisely determine the amount of liquid released at each canopy height, the resolution level of this simple test bench was sufficient to reach its goal.

Moreover, the information regarding the liquid collected by the test bench at the different canopy heights can help citrus growers to match this information with the canopy shape/density: higher spray amounts are needed where the canopy width is higher. Furthermore, the information provided by the Citrus VESPA tool about the percentage of spray liquid collected above the canopy target height constitutes important information to help farmers abide by recent regulations that strive to reduce spray losses, especially those related to spray drift.

On the other hand, the tool does not give information about the penetration of droplets into the vegetation, which is a relevant parameter for an efficient and efficacious spray application against internal citrus pests (i.e., *Aonidiella aurantii*). To estimate canopy internal deposition, the use of water-sensitive papers placed on the leaves, wood and fruits is recommended. This is an easy way to visualize the quality of spray distribution in real field conditions, i.e., to evaluate if minimum coverage has been reached in the correct location [93,94].

The Citrus VESPA tool could support the training of farmers and advisers during the PPP license courses as well as in the ambit of the mandatory training and updating activities foreseen by the Sustainable Use Directive (EC, 2009) and successive updates, both for farmers and stakeholders dealing with PPP application. Moreover, it could represent a valid tool for educating students in considering the importance of correct sprayer adjustment when operating in tree crops. Results open the door to updating the tool by adding further data from vertical spray profiles assessed with this type of test bench using other types of sprayers employed in citrus (i.e., with two reversed rotation axial fans or multi-fan) and/or with different boom configurations. From this perspective, it will be important to take into account the evolution of the citrus sprayer technology. This, together with the implementation of the relationship of the vertical spray profile with the distribution of the spray in the canopy of citrus, are future challenges for this research area.

5. Conclusions

The experiments showed that a simple visual adjustment of the spray cloud to the vegetation, which was accomplished by selecting the proper number and position of active nozzles, increased the efficiency of the application of the three tested sprayers. In general, the efficiency also increased at lower volume rate applications. Regarding the airflow speed, there was little effect on the volume collected in the upper part of the patternator, while in general, the low speed increased the amount of spray directed towards the canopy. Concerning the nozzle type, coarse droplets tended to increase the volume in the upper part of the test bench when the C1 and C2 sprayers were used, but these droplets would presumably fall in the area close to the sprayer.

The Citrus VESPA tool allows citrus growers to visually and easily understand differences in the vertical spray profile due to the different settings of the most used sprayer equipment. It demonstrates how different factors affect the distribution of the spray in the canopy and the potential losses due to drift. Its use will help to increase user awareness about the importance of adjusting the spray cloud to the vegetation, using drift-reducing nozzles, adjusting the necessary air volume, etc., as this not only reduces environmental contamination and the risks to people, fauna and flora, but also saves the amount of PPP employed, thanks to the increased efficiency of the application. The Citrus VESPA tool will be further updated to expand the number of configurations and types of sprayers used in citrus orchards.

Author Contributions: Conceptualization, C.G., P.C., P.B., P.M. and M.G.; methodology, C.G., P.C., P.B., P.M. and M.G.; formal analysis, H.I., C.G. and P.M.; investigation, C.G., H.I., P.C. and E.M.; resources, P.C. and P.B.; data curation, C.G., H.I., E.M., P.M. and P.C.; writing—original draft preparation, C.G., H.I. and P.C.; writing—review and editing, C.G., E.M., P.B., P.M., M.G., F.G., P.C.; visualization, C.G. and H.I.; supervision, C.G., E.M. and P.C.; project administration, C.G., P.C., P.B. and F.G.; funding acquisition, P.C. and P.B. All authors have read and agreed to the published version of the manuscript.

Funding: This research was funded by IVIA (internal projects number 51918 and 52204C) and by the contribution of the PERFECT LIFE project (Pesticide Reduction using Friendly and Environmentally Controlled Technologies; ref. LIFE17/ENV/ES/000205) through the LIFE financial instrument co-financed by the European Fund for Rural Development (ERDF). H. I. is the beneficiary of a scholarship co-financed by the European Social Fund (ESF).

Data Availability Statement: The data presented in this study are available on request from the corresponding author.

Acknowledgments: The authors thank Pulverizadores Fede S.L.U. and Mañez y Lozano S.L. for lending us the sprayers. Also to the IVIA staff (Iván Carrillo, Jaime Cuquerella and Alberto Fonte) who gave us their technical support.

Conflicts of Interest: The authors declare no conflict of interest.

Appendix A. Selection and Calibration of Nozzles for the Different Configurations

Table A1. Selection and calibration of nozzles for the T sprayer, with the following configuration: Adjusted to the vegetation/High & Low fan speed/Low spray volume rate/Conventional nozzles (Fine)/Pressure: 10 bar.

Nozzle Group	Nozzle	Nozzle Color	Nominal Flow (L/min)	Volume (mL/30 s)		Actual Flow (L/min)	
				Left Side	Right Side	Left Side	Right Side
1	1	-	-	-	-	-	-
	2	-	-	-	-	-	-
	3	-	-	-	-	-	-
2	1	Lilac	0.50	250	250	0.50	0.50
	2	Lilac	0.50	260	260	0.52	0.52

	3	Lilac	0.50	260	280	0.52	0.56
3	1	Yellow	1.03	510	540	1.02	1.08
	2	Yellow	1.03	510	540	1.02	1.08
	3	Yellow	1.03	520	560	1.04	1.12
4	1	Lilac	0.50	280	280	0.56	0.56
	2	Yellow	1.03	520	560	1.04	1.12
	3	Yellow	1.03	510	530	1.02	1.06
5	1	-	-	-	-	-	-
	2	Lilac	0.50	240	260	0.48	0.52
	3	Lilac	0.50	260	260	0.52	0.52
			THEORETICAL		ACTUAL		
One side flow (L/min)			8.15		8.24 8.64		
Equipment flow (L/min)			16.30		16.88		
Forward speed (km/h)			1.74		1.74		
Row spacing (m)			5.50		5.50		
Spray volume rate (L/ha)			1021.94		1058.31		

Table A2. Selection and calibration of nozzles for the T sprayer, with the following configuration: No adjusted to the vegetation/High & Low fan speed/Low spray volume rate/Conventional nozzles (Fine)/Pressure: 10 bar.

Nozzle Group	Nozzle	Nozzle Color	Nominal Flow (L/min)	Volume (mL/30 s)		Actual Flow (L/min)	
				Left Side	Right Side	Left Side	Right Side
1	1	Lilac	0.50	260	280	0.52	0.56
	2	Lilac	0.50	260	270	0.52	0.54
	3	Lilac	0.50	280	270	0.56	0.54
2	1	Lilac	0.50	250	250	0.5	0.50
	2	Lilac	0.50	260	260	0.52	0.52
	3	Lilac	0.50	260	280	0.52	0.56
3	1	Yellow	1.03	510	550	1.02	1.10
	2	Yellow	1.03	510	550	1.02	1.10
	3	Yellow	1.03	520	570	1.04	1.14
4	1	Lilac	0.50	280	280	0.56	0.56
	2	Yellow	1.03	520	580	1.04	1.16
	3	Yellow	1.03	510	530	1.02	1.06
5	1	Lilac	0.50	260	260	0.52	0.52
	2	Lilac	0.50	240	260	0.48	0.52
	3	Lilac	0.50	260	260	0.52	0.52
			THEORETICAL		ACTUAL		
One side flow (L/min)			10.15		10.36 10.90		
Equipment flow (L/min)			20.30		21.26		
Forward speed (km/h)			1.74		1.74		
Row spacing (m)			5.50		5.50		
Spray volume rate (L/ha)			1272.73		1332.92		

Table A3. Selection and calibration of nozzles for the T sprayer, with the following configuration: Adjusted to the vegetation/High & Low fan speed/High spray volume rate/Conventional nozzles (Fine)/Pressure: 10 bar.

Nozzle Group	Nozzle	Nozzle Color	Nominal Flow (L/min)	Volume (mL/30 s)		Actual Flow (L/min)	
				Left Side	Right Side	Left Side	Right Side
1	1	-	-	-	-	-	-
	2	-	-	-	-	-	-
	3	-	-	-	-	-	-
2	1	Orange	1.39	720	700	1.44	1.40
	2	Orange	1.39	680	720	1.36	1.44
	3	Orange	1.39	720	740	1.44	1.48
3	1	Black	2.78	1320	1360	2.64	2.72
	2	Black	2.78	1345	1340	2.69	2.68
	3	Black	2.78	1360	1370	2.72	2.74
4	1	Orange	1.39	650	710	1.30	1.42
	2	Black	2.78	1395	1380	2.79	2.76
	3	Black	2.78	1350	1390	2.70	2.78
5	1	-	-	-	-	-	-
	2	Orange	1.39	740	760	1.48	1.52
	3	Orange	1.39	620	730	1.24	1.46
			THEORETICAL	ACTUAL			
One side flow (L/min)			22.24			21.8	22.40
Equipment flow (L/min)			44.48			44.20	
Forward speed (km/h)			1.74			1.74	
Row spacing (m)			5.50			5.50	
Spray volume rate (L/ha)			2788.71			2771.16	

Table A4. Selection and calibration of nozzles for the T sprayer, with the following configuration: No adjusted to the vegetation/High & Low fan speed/High spray volume rate/Conventional nozzles (Fine)/Pressure: 10 bar.

Nozzle Group	Nozzle	Nozzle Color	Nominal Flow (L/min)	Volume (mL/30 s)		Actual Flow (L/min)	
				Left Side	Right Side	Left Side	Right Side
1	1	Orange	1.39	680	760	1.36	1.52
	2	Orange	1.39	680	720	1.36	1.44
	3	Orange	1.39	680	730	1.36	1.46
2	1	Orange	1.39	720	720	1.44	1.44
	2	Orange	1.39	680	720	1.36	1.44
	3	Orange	1.39	720	760	1.44	1.52
3	1	Black	2.78	1320	1360	2.64	2.72
	2	Black	2.78	1345	1360	2.69	2.72
	3	Black	2.78	1360	1410	2.72	2.82
4	1	Orange	1.39	650	710	1.30	1.42
	2	Black	2.78	1395	1380	2.79	2.76
	3	Black	2.78	1350	1390	2.70	2.78
5	1	Orange	1.39	640	680	1.28	1.36
	2	Orange	1.39	740	760	1.48	1.52
	3	Orange	1.39	620	730	1.24	1.46
			THEORETICAL	ACTUAL			

One side flow (L/min)	27.8	27.16	28.38
Equipment flow (L/min)	55.60	55.54	
Forward speed (km/h)	1.74	1.74	
Row spacing (m)	5.50	5.50	
Spray volume rate (L/ha)	3485.89	3482.13	

Table A5. Selection and calibration of nozzles for the T sprayer, with the following configuration: Adjusted to the vegetation/High & Low fan speed/Low spray volume rate/Drift-reducing nozzles (Coarse)/Pressure: 9 bar.

Nozzle Group	Nozzle	Nozzle Color	Nominal Flow (L/min)	Volume (mL/30 s)		Actual Flow (L/min)	
				Left Side	Right Side	Left Side	Right Side
1	1	-	-	-	-	-	-
	2	-	-	-	-	-	-
	3	-	-	-	-	-	-
2	1	Pink	0.52	260	290	0.52	0.58
	2	Pink	0.52	270	290	0.54	0.58
	3	Pink	0.52	280	290	0.56	0.58
3	1	Green	1.04	560	580	1.12	1.16
	2	Green	1.04	540	570	1.08	1.14
	3	Green	1.04	540	570	1.08	1.14
4	1	Pink	0.52	280	290	0.56	0.58
	2	Green	1.04	560	580	1.12	1.16
	3	Green	1.04	570	580	1.14	1.16
5	1	-	-	-	-	-	-
	2	Pink	0.52	290	300	0.58	0.60
	3	Pink	0.52	290	300	0.58	0.60
THEORETICAL				ACTUAL			
One side flow (L/min)			8.32			8.88	9.28
Equipment flow (L/min)			16.64			18.16	
Forward speed (km/h)			1.74			1.74	
Row spacing (m)			5.50			5.50	
Spray volume rate (L/ha)			1043.26			1138.56	

Table A6. Selection and calibration of nozzles for the T sprayer, with the following configuration: No adjusted to the vegetation/High & Low fan speed/Low spray volume rate/Drift-reducing nozzles (Coarse)/Pressure: 9 bar.

Nozzle Group	Nozzle	Nozzle Color	Nominal Flow (L/min)	Volume (mL/30 s)		Actual Flow (L/min)	
				Left Side	Right Side	Left Side	Right Side
1	1	Pink	0.52	270	290	0.54	0.58
	2	Pink	0.52	260	290	0.52	0.58
	3	Pink	0.52	290	280	0.58	0.56
2	1	Pink	0.52	260	290	0.52	0.58
	2	Pink	0.52	270	290	0.54	0.58
	3	Pink	0.52	280	280	0.56	0.56
3	1	Green	1.04	560	580	1.12	1.16
	2	Green	1.04	540	570	1.08	1.14
	3	Green	1.04	540	570	1.08	1.14
4	1	Pink	0.52	280	290	0.56	0.58

	2	Green	1.04	560	580	1.12	1.16
	3	Green	1.04	570	580	1.14	1.16
	1	Pink	0.52	300	290	0.60	0.58
5	2	Pink	0.52	290	300	0.58	0.60
	3	Pink	0.52	290	300	0.58	0.60
			THEORETICAL		ACTUAL		
One side flow (L/min)			10.40			11.12	11.56
Equipment flow (L/min)			20.80			22.68	
Forward speed (km/h)			1.74			1.74	
Row spacing (m)			5.50			5.50	
Spray volume rate (L/ha)			1304.08			1421.94	

Table A7. Selection and calibration of nozzles for the T sprayer, with the following configuration: Adjusted to the vegetation/High & Low fan speed/High spray volume rate/Drift-reducing nozzles (Coarse)/Pressure: 9 bar.

Nozzle Group	Nozzle	Nozzle Color	Nominal Flow (L/min)	Volume (mL/30 s)		Actual Flow (L/min)	
				Left Side	Right Side	Left Side	Right Side
1	1	-	-	-	-	-	-
	2	-	-	-	-	-	-
	3	-	-	-	-	-	-
2	1	Yellow	1.39	700	720	1.40	1.44
	2	Yellow	1.39	700	740	1.40	1.48
	3	Yellow	1.39	700	760	1.40	1.52
3	1	Red	2.77	1260	1340	2.52	2.68
	2	Red	2.77	1260	1360	2.52	2.72
	3	Red	2.77	1240	1360	2.48	2.72
4	1	Yellow	1.39	700	720	1.40	1.44
	2	Red	2.77	1250	1380	2.50	2.76
	3	Red	2.77	1260	1360	2.52	2.72
5	1	-	-	-	-	-	-
	2	Yellow	1.39	725	750	1.45	1.50
	3	Yellow	1.39	700	740	1.40	1.48
			THEORETICAL		ACTUAL		
One side flow (L/min)			22.19			20.99	22.46
Equipment flow (L/min)			44.38			43.45	
Forward speed (km/h)			1.74			1.74	
Row spacing (m)			5.50			5.50	
Spray volume rate (L/ha)			2782.45			2724.14	

Table A8. Selection and calibration of nozzles for the T sprayer, with the following configuration: No adjusted to the vegetation/High & Low fan speed/High spray volume rate/Drift-reducing nozzles (Coarse)/Pressure: 9 bar.

Nozzle Group	Nozzle	Nozzle Color	Nominal Flow (L/min)	Volume (mL/30 s)		Actual Flow (L/min)	
				Left Side	Right Side	Left Side	Right Side
1	1	Yellow	1.39	700	750	1.40	1.50
	2	Yellow	1.39	725	730	1.45	1.46
	3	Yellow	1.39	700	750	1.40	1.50
2	1	Yellow	1.39	700	720	1.40	1.44
	2	Yellow	1.39	700	740	1.40	1.48
	3	Yellow	1.39	700	760	1.40	1.52
3	1	Red	2.77	1260	1340	2.52	2.68
	2	Red	2.77	1260	1380	2.52	2.76
	3	Red	2.77	1240	1380	2.48	2.76
4	1	Yellow	1.39	700	730	1.40	1.46
	2	Red	2.77	1250	1390	2.50	2.78
	3	Red	2.77	1260	1360	2.52	2.72
5	1	Yellow	1.39	725	730	1.45	1.46
	2	Yellow	1.39	725	750	1.45	1.50
	3	Yellow	1.39	700	740	1.40	1.48
			THEORETICAL	ACTUAL			
One side flow (L/min)			27.75			26.69	28.5
Equipment flow (L/min)			55.50			55.19	
Forward speed (km/h)			1.74			1.74	
Row spacing (m)			5.50			5.50	
Spray volume rate (L/ha)			3479.62			3460.19	

Table A9. Selection and calibration of nozzles for the C2 sprayer, with the following configuration: Adjusted to the vegetation/High & Low fan speed/Low spray volume rate/Conventional nozzles (Fine)/Pressure: 9 bar.

Nozzle	Nozzle Color	Nominal Flow (L/min)	Volume (mL/30 s)		Actual Flow (L/min)		
			Left Side	Right Side	Left Side	Right Side	
1	-	-	-	-	-	-	
2	Yellow	0.97	520	520	1.04	1.04	
3	Yellow	0.97	500	510	1.00	1.02	
4	Yellow	0.97	500	500	1.00	1.00	
5	Yellow	0.97	510	520	1.02	1.04	
6	Yellow	0.97	520	520	1.04	1.04	
7	-	-	-	-	-	-	
8	-	-	-	-	-	-	
9	Yellow	0.97	540	520	1.08	1.04	
10	Yellow	0.97	520	500	1.04	1.00	
11	Yellow	0.97	500	520	1.00	1.04	
12	Yellow	0.97	540	500	1.08	1.00	
13	-	-	-	-	-	-	
			THEORETICAL	ACTUAL			
One side flow (L/min)			8.73			9.30	9.22
Equipment flow (L/min)			17.46			18.52	

Forward speed (km/h)	1.74	1.74
Row spacing (m)	5.50	5.50
Spray volume rate (L/ha)	1094.67	1161.13

Table A10. Selection and calibration of nozzles for the C2 sprayer, with the following configuration: No adjusted to the vegetation/High & Low fan speed/Low spray volume rate/Conventional nozzles (Fine)/Pressure: 9 bar.

Nozzle	Nozzle Color	Nominal Flow (L/min)	Volume (mL/30 s)		Actual Flow (L/min)	
			Left Side	Right Side	Left Side	Right Side
1	Yellow	0.97	500	540	1.00	1.08
2	Yellow	0.97	520	520	1.04	1.04
3	Yellow	0.97	500	510	1.00	1.02
4	Yellow	0.97	500	500	1.00	1.00
5	Yellow	0.97	510	520	1.02	1.04
6	Yellow	0.97	520	520	1.04	1.04
7	Yellow	0.97	500	500	1.00	1.00
8	Yellow	0.97	550	500	1.10	1.00
9	Yellow	0.97	540	520	1.08	1.04
10	Yellow	0.97	520	500	1.04	1.00
11	Yellow	0.97	500	520	1.00	1.04
12	Yellow	0.97	540	500	1.08	1.00
13	Yellow	0.97	500	520	1.00	1.04
THEORETICAL			ACTUAL			
One side flow (L/min)	12.61				13.40	13.34
Equipment flow (L/min)	25.22				26.74	
Forward speed (km/h)	1.74				1.74	
Row spacing (m)	5.50				5.50	
Spray volume rate (L/ha)	1581.19				1676.49	

Table A11. Selection and calibration of nozzles for the C2 sprayer, with the following configuration: Adjusted to the vegetation/High & Low fan speed/High spray volume rate/Conventional nozzles (Fine)/Pressure: 9 bar.

Nozzle	Nozzle Color	Nominal Flow (L/min)	Volume (mL/30 s)		Actual Flow (L/min)	
			Left Side	Right Side	Left Side	Right Side
1	-	-	-	-	-	-
2	Black	2.64	1320	1300	2.64	2.60
3	Black	2.64	1380	1310	2.76	2.62
4	Black	2.64	1380	1320	2.76	2.64
5	Black	2.64	1380	1390	2.76	2.78
6	Black	2.64	1400	1320	2.80	2.64
7	-	-	-	-	-	-
8	-	-	-	-	-	-
9	Black	2.64	1370	1360	2.74	2.72
10	Black	2.64	1340	1320	2.68	2.64
11	Black	2.64	1300	1320	2.60	2.64
12	Black	2.64	1360	1320	2.72	2.64
13	-	-	-	-	-	-
THEORETICAL			ACTUAL			
One side flow (L/min)	23.76				24.46	23.92

Equipment flow (L/min)	47.52	48.38
Forward speed (km/h)	1.74	1.74
Row spacing (m)	5.50	5.50
Spray volume rate (L/ha)	2979.31	3033.23

Table A12. Selection and calibration of nozzles for the C2 sprayer, with the following configuration: No adjusted to the vegetation/High & Low fan speed/High spray volume rate/Conventional nozzles (Fine)/Pressure: 9 bar.

Nozzle	Nozzle Color	Nominal Flow (L/min)	Volume (mL/30 s)		Actual Flow (L/min)	
			Left Side	Right Side	Left Side	Right Side
1	Black	2.64	1360	1380	2.72	2.76
2	Black	2.64	1320	1300	2.64	2.60
3	Black	2.64	1340	1310	2.68	2.62
4	Black	2.64	1380	1320	2.76	2.64
5	Black	2.64	1310	1390	2.62	2.78
6	Black	2.64	1360	1320	2.72	2.64
7	Black	2.64	1340	1320	2.68	2.64
8	Black	2.64	1320	1320	2.64	2.64
9	Black	2.64	1280	1360	2.56	2.72
10	Black	2.64	1380	1320	2.76	2.64
11	Black	2.64	1380	1320	2.76	2.64
12	Black	2.64	1340	1320	2.68	2.64
13	Black	2.64	1310	1240	2.62	2.48
		THEORETICAL			ACTUAL	
One side flow (L/min)		34.32			34.84	34.44
Equipment flow (L/min)		68.64			69.28	
Forward speed (km/h)		1.74			1.74	
Row spacing (m)		5.50			5.50	
Spray volume rate (L/ha)		4303.45			4343.57	

Table A13. Selection and calibration of nozzles for the C2 sprayer, with the following configuration: Adjusted to the vegetation/High & Low fan speed/Low spray volume rate/Drift-reducing nozzles (Coarse)/Pressure: 15 bar.

Nozzle	Nozzle Color	Nominal Flow (L/min)	Volume (mL/30 s)		Actual Flow (L/min)	
			Left Side	Right Side	Left Side	Right Side
1	-	-	-	-	-	-
2	Orange	0.89	420	460	0.84	0.92
3	Orange	0.89	420	460	0.84	0.92
4	Orange	0.89	430	460	0.86	0.92
5	Orange	0.89	430	460	0.86	0.92
6	Orange	0.89	420	460	0.84	0.92
7	-	-	-	-	-	-
8	-	-	-	-	-	-
9	Orange	0.89	420	460	0.84	0.92
10	Orange	0.89	440	455	0.88	0.91
11	Orange	0.89	440	460	0.88	0.92
12	Orange	0.89	440	460	0.88	0.92
13	-	-	-	-	-	-
		THEORETICAL			ACTUAL	

One side flow (L/min)	8.01	7.72	8.27
Equipment flow (L/min)	16.02	15.99	
Forward speed (km/h)	1.74	1.74	
Row spacing (m)	5.50	5.50	
Spray volume rate (L/ha)	1004.39	1002.51	

Table A14. Selection and calibration of nozzles for the C2 sprayer, with the following configuration: No adjusted to the vegetation/High & Low fan speed/Low spray volume rate/Drift-reducing nozzles (Coarse)/Pressure: 15 bar.

Nozzle	Nozzle Color	Nominal Flow (L/min)	Volume (mL/30 s)		Actual Flow (L/min)		
			Left Side	Right Side	Left Side	Right Side	
1	Orange	0.89	440	460	0.88	0.92	
2	Orange	0.89	420	460	0.84	0.92	
3	Orange	0.89	420	460	0.84	0.92	
4	Orange	0.89	430	460	0.86	0.92	
5	Orange	0.89	430	460	0.86	0.92	
6	Orange	0.89	420	460	0.84	0.92	
7	Orange	0.89	420	460	0.84	0.92	
8	Orange	0.89	430	460	0.86	0.92	
9	Orange	0.89	420	460	0.84	0.92	
10	Orange	0.89	440	455	0.88	0.91	
11	Orange	0.89	440	460	0.88	0.92	
12	Orange	0.89	440	460	0.88	0.92	
13	Orange	0.89	430	460	0.86	0.92	
		THEORETICAL			ACTUAL		
One side flow (L/min)		11.57			11.16	11.95	
Equipment flow (L/min)		23.14			23.11		
Forward speed (km/h)		1.74			1.74		
Row spacing (m)		5.50			5.50		
Spray volume rate (L/ha)		1450.78			1448.90		

Table A15. Selection and calibration of nozzles for the C2 sprayer, with the following configuration: Adjusted to the vegetation/High & Low fan speed/High spray volume rate/Drift-reducing nozzles (Coarse)/Pressure: 15 bar.

Nozzle	Nozzle Color	Nominal Flow (L/min)	Volume (mL/30 s)		Actual Flow (L/min)	
			Left Side	Right Side	Left Side	Right Side
1	-	-	-	-	-	-
2	Blue	2.68	1330	1340	2.66	2.68
3	Blue	2.68	1340	1340	2.68	2.68
4	Blue	2.68	1340	1340	2.68	2.68
5	Blue	2.68	1350	1330	2.70	2.66
6	Blue	2.68	1340	1330	2.68	2.66
7	-	-	-	-	-	-
8	-	-	-	-	-	-
9	Blue	2.68	1340	1320	2.68	2.64
10	Blue	2.68	1360	1350	2.72	2.70
11	Blue	2.68	1360	1350	2.72	2.70
12	Blue	2.68	1340	1380	2.68	2.76
13	-	-	-	-	-	-

	THEORETICAL	ACTUAL	
One side flow (L/min)	24.12	24.20	24.16
Equipment flow (L/min)	48.24	48.36	
Forward speed (km/h)	1.74	1.74	
Row spacing (m)	5.50	5.50	
Spray volume rate (L/ha)	3024.45	3031.97	

Table A16. Selection and calibration of nozzles for the C2 sprayer, with the following configuration: No adjusted to the vegetation/High & Low fan speed/High spray volume rate/Drift-reducing nozzles (Coarse)/Pressure: 15 bar.

Nozzle	Nozzle Color	Nominal Flow (L/min)	Volume (mL/30 s)		Actual Flow (L/min)	
			Left Side	Right Side	Left Side	Right Side
1	Blue	2.68	1360	1340	2.72	2.68
2	Blue	2.68	1330	1340	2.66	2.68
3	Blue	2.68	1340	1340	2.68	2.68
4	Blue	2.68	1340	1340	2.68	2.68
5	Blue	2.68	1350	1330	2.70	2.66
6	Blue	2.68	1340	1330	2.68	2.66
7	Blue	2.68	1350	1360	2.70	2.72
8	Blue	2.68	1340	1340	2.68	2.68
9	Blue	2.68	1340	1320	2.68	2.64
10	Blue	2.68	1360	1350	2.72	2.70
11	Blue	2.68	1360	1350	2.72	2.70
12	Blue	2.68	1340	1380	2.68	2.76
13	Blue	2.68	1340	1360	2.68	2.72

	THEORETICAL	ACTUAL	
One side flow (L/min)	34.84	34.98	34.96
Equipment flow (L/min)	69.68	69.94	
Forward speed (km/h)	1.74	1.74	
Row spacing (m)	5.50	5.50	
Spray volume rate (L/ha)	4368.65	4384.95	

Table A17. Selection and calibration of nozzles for the C1 sprayer, with the following configuration: Adjusted to the vegetation/High & Low fan speed/Low spray volume rate/Conventional nozzles (Fine)/Pressure: 13 bar.

Nozzle	Nozzle Color	Nominal Flow (L/min)	Volume (mL/30 s)		Actual Flow (L/min)	
			Left Side	Right Side	Left Side	Right Side
1	-	-	-	-	-	-
2	-	-	-	-	-	-
3	-	-	-	-	-	-
4	-	-	-	-	-	-
5	-	-	-	-	-	-
6	-	-	-	-	-	-
7	-	-	-	-	-	-
8	Orange	1.57	820	790	1.64	1.58
9	Orange	1.57	830	780	1.66	1.56
10	Orange	1.57	820	800	1.64	1.60
11	Orange	1.57	840	820	1.68	1.64
12	Orange	1.57	820	810	1.64	1.62

13	-	-	-	-	-	-
	THEORETICAL			ACTUAL		
One side flow (L/min)	7.85			8.26	8.00	
Equipment flow (L/min)	15.70			16.26		
Forward speed (km/h)	1.74			1.74		
Row spacing (m)	5.50			5.50		
Spray volume rate (L/ha)	984.33			1019.44		

Table A18. Selection and calibration of nozzles for the C1 sprayer, with the following configuration: No adjusted to the vegetation/High & Low fan speed/Low spray volume rate/Conventional nozzles (Fine)/Pressure: 13 bar.

Nozzle	Nozzle Color	Nominal Flow (L/min)	Volume (mL/30 s)		Actual Flow (L/min)	
			Left Side	Right Side	Left Side	Right Side
1	-	-	-	-	-	-
2	-	-	-	-	-	-
3	-	-	-	-	-	-
4	-	-	-	-	-	-
5	-	-	-	-	-	-
6	-	-	-	-	-	-
7	Orange	1.57	840	810	1.68	1.62
8	Orange	1.57	820	790	1.64	1.58
9	Orange	1.57	830	780	1.66	1.56
10	Orange	1.57	820	800	1.64	1.60
11	Orange	1.57	840	820	1.68	1.64
12	Orange	1.57	820	810	1.64	1.62
13	Orange	1.57	800	800	1.60	1.60
	THEORETICAL			ACTUAL		
One side flow (L/min)	10.99			11.54	11.22	
Equipment flow (L/min)	21.98			22.76		
Forward speed (km/h)	1.74			1.74		
Row spacing (m)	5.50			5.50		
Spray volume rate (L/ha)	1378.06			1426.96		

Table A19. Selection and calibration of nozzles for the C1 sprayer, with the following configuration: Adjusted to the vegetation/High & Low fan speed/High spray volume rate/Conventional nozzles (Fine)/Pressure: 15 bar.

Nozzle	Nozzle Color	Nominal Flow (L/min)	Volume (mL/15 s)		Actual Flow (L/min)	
			Left Side	Right Side	Left Side	Right Side
1	-	-	-	-	-	-
2	-	-	-	-	-	-
3	-	-	-	-	-	-
4	-	-	-	-	-	-
5	-	-	-	-	-	-
6	-	-	-	-	-	-
7	-	-	-	-	-	-
8	Blue	4.12	1060	1090	4.24	4.36
9	Blue	4.12	1040	1120	4.16	4.48
10	Blue	4.12	1100	1090	4.40	4.36
11	Blue	4.12	1120	1080	4.48	4.32

12	Blue	4.12	1060	1120	4.24	4.48
13	-	-	-	-	-	-
		THEORETICAL			ACTUAL	
One side flow (L/min)		20.60			21.52	22.00
Equipment flow (L/min)		41.20			43.52	
Forward speed (km/h)		1.74			1.74	
Row spacing (m)		5.50			5.50	
Spray volume rate (L/ha)		2583.07			2728.53	

Table A20. Selection and calibration of nozzles for the C1 sprayer, with the following configuration: No adjusted to the vegetation/High & Low fan speed/High spray volume rate/Conventional nozzles (Fine)/Pressure: 15 bar.

Nozzle	Nozzle Color	Nominal Flow (L/min)	Volume (mL/15 s)		Actual Flow (L/min)	
			Left Side	Right Side	Left Side	Right Side
1	-	-	-	-	-	-
2	-	-	-	-	-	-
3	-	-	-	-	-	-
4	-	-	-	-	-	-
5	-	-	-	-	-	-
6	-	-	-	-	-	-
7	Blue	4.12	1020	1100	4.08	4.40
8	Blue	4.12	1060	1090	4.24	4.36
9	Blue	4.12	1040	1120	4.16	4.48
10	Blue	4.12	1100	1090	4.40	4.36
11	Blue	4.12	1120	1080	4.48	4.32
12	Blue	4.12	1060	1120	4.24	4.48
13	Blue	4.12	1120	1100	4.48	4.40
		THEORETICAL			ACTUAL	
One side flow (L/min)		28.84			30.08	30.80
Equipment flow (L/min)		57.68			60.88	
Forward speed (km/h)		1.74			1.74	
Row spacing (m)		5.50			5.50	
Spray volume rate (L/ha)		3616.30			3816.93	

Table A21. Selection and calibration of nozzles for the C1 sprayer, with the following configuration: Adjusted to the vegetation/High & Low fan speed/Low spray volume rate/Drift-reducing nozzles (Coarse)/Pressure: 12 bar.

Nozzle	Nozzle Color	Nominal Flow (L/min)	Volume (mL/30 s)		Actual Flow (L/min)	
			Left Side	Right Side	Left Side	Right Side
1	-	-	-	-	-	-
2	-	-	-	-	-	-
3	-	-	-	-	-	-
4	-	-	-	-	-	-
5	-	-	-	-	-	-
6	-	-	-	-	-	-
7	-	-	-	-	-	-
8	Yellow	1.60	820	840	1.64	1.68
9	Yellow	1.60	800	830	1.60	1.66
10	Yellow	1.60	810	820	1.62	1.64

11	Yellow	1.60	820	840	1.64	1.68
12	Yellow	1.60	820	820	1.64	1.64
13	-	-	-	-	-	-
		THEORETICAL			ACTUAL	
One side flow (L/min)		8.00			8.14	8.30
Equipment flow (L/min)		16.00			16.44	
Forward speed (km/h)		1.74			1.74	
Row spacing (m)		5.50			5.50	
Spray volume rate (L/ha)		1003.13			1030.72	

Table A22. Selection and calibration of nozzles for the C1 sprayer, with the following configuration: No adjusted to the vegetation/High & Low fan speed/Low spray volume rate/Drift-reducing nozzles (Coarse)/Pressure: 12 bar.

Nozzle	Nozzle Color	Nominal Flow (L/min)	Volume (mL/30 s)		Actual Flow (L/min)	
			Left Side	Right Side	Left Side	Right Side
1	-	-	-	-	-	-
2	-	-	-	-	-	-
3	-	-	-	-	-	-
4	-	-	-	-	-	-
5	-	-	-	-	-	-
6	-	-	-	-	-	-
7	Yellow	1.60	800	840	1.60	1.68
8	Yellow	1.60	820	840	1.64	1.68
9	Yellow	1.60	800	830	1.60	1.66
10	Yellow	1.60	810	820	1.62	1.64
11	Yellow	1.60	820	840	1.64	1.68
12	Yellow	1.60	820	820	1.64	1.64
13	Yellow	1.60	800	850	1.60	1.70
		THEORETICAL			ACTUAL	
One side flow (L/min)		11.20			11.34	11.68
Equipment flow (L/min)		22.40			23.02	
Forward speed (km/h)		1.74			1.74	
Row spacing (m)		5.50			5.50	
Spray volume rate (L/ha)		1404.39			1443.26	

Table A23. Selection and calibration of nozzles for the C1 sprayer, with the following configuration: Adjusted to the vegetation/High & Low fan speed/High spray volume rate/Drift-reducing nozzles (Coarse)/Pressure: 16 bar.

Nozzle	Nozzle Color	Nominal Flow (L/min)	Volume (mL/15 s)		Actual Flow (L/min)	
			Left Side	Right Side	Left Side	Right Side
1	-	-	-	-	-	-
2	-	-	-	-	-	-
3	-	-	-	-	-	-
4	-	-	-	-	-	-
5	-	-	-	-	-	-
6	-	-	-	-	-	-
7	-	-	-	-	-	-
8	Red	3.70	900	920	3.60	3.68
9	Red	3.70	910	920	3.64	3.68

10	Red	3.70	920	920	3.68	3.68
11	Red	3.70	900	920	3.60	3.68
12	Red	3.70	900	920	3.60	3.68
13	-	-	-	-	-	-
		THEORETICAL		ACTUAL		
One side flow (L/min)		18.50			18.12	18.40
Equipment flow (L/min)		37.00			36.52	
Forward speed (km/h)		1.74			1.74	
Row spacing (m)		5.50			5.50	
Spray volume rate (L/ha)		2319.75			2289.66	

Table A24. Selection and calibration of nozzles for the C1 sprayer, with the following configuration: No adjusted to the vegetation/High & Low fan speed/High spray volume rate/Drift-reducing nozzles (Coarse)/Pressure: 16 bar.

Nozzle	Nozzle Color	Nominal Flow (L/min)	Volume (ml/15 s)		Actual flow (L/min)	
			Left Side	Right Side	Left Side	Right Side
1	-	-	-	-	-	-
2	-	-	-	-	-	-
3	-	-	-	-	-	-
4	-	-	-	-	-	-
5	-	-	-	-	-	-
6	-	-	-	-	-	-
7	Red	3.70	900	920	3.60	3.68
8	Red	3.70	900	920	3.60	3.68
9	Red	3.70	910	920	3.64	3.68
10	Red	3.70	920	920	3.68	3.68
11	Red	3.70	900	920	3.60	3.68
12	Red	3.70	900	920	3.60	3.68
13	Red	3.70	920	920	3.68	3.68
		THEORETICAL		ACTUAL		
One side flow (L/min)		25.90			25.40	25.76
Equipment flow (L/min)		51.80			51.16	
Forward speed (km/h)		1.74			1.74	
Row spacing (m)		5.50			5.50	
Spray volume rate (L/ha)		3247.65			3207.52	

Appendix B

Average Air Speed in the Measurement Points of Figure 5.

Table B1. Average air speed (m/s) in the measurement points of the C sprayer.

Measurement Point	Air Speed (m/s)			
	High Gear-Box		Low Gear-Box	
	Right Side	Left Side	Right Side	Left Side
1	29.1	32.9	24.3	29.1
2	35.0	34.3	29.6	35.0
3	34.9	32.9	28.9	34.9
4	36.8	31.1	30.0	36.8
5	37.1	32.3	30.4	37.1
6	39.0	33.9	32.0	39.0

7	38.2	39.4	31.4	38.2
8	44.5	48.0	35.6	44.5
9	44.5	45.1	37.2	44.5
10	45.6	45.0	37.7	45.6
11	44.5	42.8	37.8	44.5
12	45.9	44.0	37.5	45.9
13	46.3	45.9	37.2	46.3
14	46.7	49.5	37.4	46.7
15	25.7	22.6	20.7	25.7
16	36.5	35.6	33.7	36.5
17	36.1	27.2	20.7	36.1

Table B2. Average air speed (m/s) in the measurement points of the T sprayer.

Nozzle Holder	Measurement Point	Air Speed (m/s)			
		High Gear-Box		Low Gear-Box	
		Right Side	Left Side	Right Side	Left Side
1	a	35.5	29.9	29.9	26.6
	b	32.5	39.4	27.3	31.5
	i	37.0	33.0	30.6	25.3
	e	14.2	17.0	12.7	14.3
2	a	37.1	40.0	29.5	33.1
	b	36.4	42.2	26.7	30.9
	i	37.0	23.6	30.6	21.8
	e	22.4	11.4	10.9	11.5
3	a	39.2	41	30.1	32.7
	b	36.1	36.5	26.3	29.7
	i	45.3	31.5	37.3	13.5
	e	12.7	19.0	16.4	23.6
4	a	42.0	41.6	33.2	31.7
	b	36.2	50.0	28.5	39.3
	i	50.0	27.0	14.2	24.4
	e	38.9	20.1	37.5	12.8
5	a	42.1	35.8	34.3	28.7
	b	38.7	44.0	31.5	30.5
	i	35.7	28.0	35.3	22.4
	e	28.6	31.0	28.7	27.0

References

- Balsari, P.; Marucco, P.; Oggero, G. Spray Application in Italian Apple Orchards: Target Coverage, Ground Losses and Drift. In Proceedings of the ASAE Annual International Meeting, Chicago, IL, USA, 28–31 July 2002. <http://doi.org/10.13031/2013.9337>.
- Viret, O.; Siegfried, W.; Holliger, E.; Raisigl, U. Comparison of spray deposits and efficacy against powdery mildew of aerial and ground-based spraying equipment in viticulture. *Crop Prot.* **2003**, *22*, 1023–1032.
- Balsari, P.; Marucco, P.; Tamagnone, M. A system to assess the mass balance of spray applied to tree crops. *Trans. ASAE* **2005**, *48*, 1689–1694. <https://doi.org/10.13031/2013.19997>.
- Salyani, M.; Farooq, M.; Sweeb, R.D. Spray deposition and mass balance in citrus orchard applications. *Trans. ASABE* **2007**, *50*, 1963e–1969e.
- Jensen, P.K.; Olesen, M.H. Spray mass balance in pesticide application: A review. *Crop Prot.* **2014**, *61*, 23–31. <http://doi.org/10.1016/j.cropro.2014.03.006>.
- Garcerá, C.; Moltó, E.; Chueca, P. Spray pesticide applications in Mediterranean citrus orchards: Canopy deposition and off-target losses. *Sci. Total Environ.* **2017**, *599–600*, 1344–1362. <http://doi.org/10.1016/j.scitotenv.2017.05.029>.
- Grella, M.; Marucco, P.; Oggero, G.; Manzone, M.; Gioelli, F.S.; Balsari, P. Environmental Evaluation of Vineyard Airblast Sprayers through a Comprehensive Spray Mass-Balance Approach. In *Safety, Health and Welfare in Agriculture and Agro-food Systems*.

- SHWA 2020. *Lecture Notes in Civil Engineering*; Biocca, M., Cavallo, E., Cecchini, M., Failla, S., Romano, E., Eds.; Springer: Cham, Switzerland, 2022; Volume 252, pp. 383–393. https://doi.org/10.1007/978-3-030-98092-4_39.
8. Praat, J.-P.; Maber, J.F.; Manktelow, D.W.L. The effect of canopy development and sprayer position on spray drift from a pipfruit orchard. *N. Z. Plant Prot.* **2000**, *53*, 241–247.
 9. Duga, A.T.; Ruysen, K.; Dekeyser, D.; Nuyttens, D.; Bylemans, D.; Nicolai, B.M.; Verboven, P. Spray deposition profiles in pome fruit trees: Effects of sprayer design, training system and tree canopy characteristics. *Crop Prot.* **2015**, *67*, 200–213. <http://doi.org/10.1016/j.cropro.2014.10.016>.
 10. Yeary, W.; Fulcher, A.; Zhu, H.; Klingeman, W.; Grant, J. Spray penetration and natural enemy survival in dense and sparse plant canopies treated with carbaryl: Implications for chemical and biological control. *J. Environ. Hortic.* **2018**, *36*, 21–29.
 11. Pergher, G.; Zucchiatti, N. Influence of canopy development in the vineyard on spray deposition from a tunnel sprayer. *J. Agric. Eng.* **2018**, *49*, 164–173. <https://doi.org/10.4081/jae.2018.801>.
 12. Garcerá, C.; Fonte, A.; Salcedo, R.; Soler, A.; Chueca, P. Dose expression for pesticide application in citrus: Influence of canopy size and sprayer. *Agronomy* **2020**, *10*, 1887. <https://doi.org/10.3390/agronomy10121887>.
 13. Świechowski, W.; Doruchowski, G.; Hołownicki, R.; Godyń, A. Penetration of air within the apple tree canopy as affected by the air jet characteristics and travel velocity of the sprayer. *EJPAU* **2004**, *7*, 3. Available online: <http://www.ejpau.media.pl/volume7/issue2/engineering/art-03.html> (accessed on 9 May 2022).
 14. Grella, M.; Marucco, P.; Gioelli, F.; Balsari, P.; Athanasakos, L.; Mylonas, N.; Fountas, S.; Zwervaegher, I.; Nuyttens, D.; Caffini, A.; et al. Airblast sprayer electrification for real-time, continuous fan-airflow adjustment according to canopy density during pesticide application in 3D crops. In *VDI-Berichte: LAND. TECHNIK 2022-The Forum for Agricultural Engineering Innovations*; VDI Wissenforum GmbH: Düsseldorf, Germany, 2022; Volume 2395, pp. 389–395. <https://doi.org/10.51202/9783181023952-389>.
 15. Cross, J.V.; Walklate, P.J.; Murray, R.A.; Richardson, G.M. Spray deposits and losses in different sized apple trees from an axial fan orchard sprayer: 2. Effects of spray quality. *Crop Prot.* **2001**, *20*, 333–343.
 16. Cross, J.V.; Walklate, P.J.; Murray, R.A.; Richardson, G.M. Spray deposits and losses in different sized apple trees from an axial fan orchard sprayer: 3. Effects of air volumetric flow rate. *Crop Prot.* **2003**, *22*, 381–394.
 17. Rincón, V.J.; Grella, M.; Marucco, P.; Eloi Alcatrão, L.; Sanchez-Hermosilla, J.; Balsari, P. Spray performance assessment of a remote-controlled vehicle prototype for pesticide application in greenhouse tomato crops. *Sci. Total Environ.* **2020**, *726*, 138509. <https://doi.org/10.1016/j.scitotenv.2020.138509>.
 18. Grella, M.; Fabrizio, G.; Marucco, P.; Zwervaegher, I.; Mozzanini, E.; Mylonas, N.; Nuyttens, D.; Balsari, P. Field assessment of a pulse width modulation spray system applying different spray volumes: Duty cycle and forward speed effects on vines spray coverage. *Precis. Agric.* **2022**, *23*, 219–252. <https://doi.org/10.1007/s11119-021-09835-6>.
 19. Heinkel, R.; Fried, A.; Lange, E. The effect of air injector nozzles on crop penetration and biological performance of fruit sprayers. *Asp. Appl. Biol. Int. Adv. Pestic. Appl.* **2000**, *57*, 301–307.
 20. Bouse, L.F.; Kirk, I.W.; Bode, L.E. Effect of spray mixture on droplet size. *Trans. ASAE* **1990**, *33*, 783–788.
 21. De Schampheleire, M.; Nuyttens, D.; Baetens, K.; Cornelis, W.; Gabriels, D.; Spanoghe, P. Effects on pesticide spray drift of the physicochemical properties of the spray liquid. *Precis. Agric.* **2009**, *10*, 409–420. <https://doi.org/10.1007/s11119-008-9089-6>.
 22. Butler Ellis, M.C.; Lane, A.G.; O’Sullivan, C.M.; Miller, P.C.H.; Glass, C.R. Bystander exposure to pesticide spray drift: New data for model development and validation. *Biosyst. Eng.* **2010**, *107*, 162–168. <https://doi.org/10.1016/j.biosystemseng.2010.05.017>.
 23. Felsot, A.S.; Unsworth, J.B.; Linders, J.B.H.J.; Roberts, G. Agrochemical spray drift; assessment and mitigation—A review. *J. Environ. Sci. Health B* **2011**, *46*, 1–23.
 24. Grella, M.; Gallart, M.; Marucco, P.; Balsari, P.; Gil, E. Ground deposition and airborne spray drift assessment in vineyard and orchard: The influence of environmental variables and sprayer settings. *Sustainability* **2017**, *9*, 728. <https://doi.org/10.3390/su9050728>.
 25. Grella, M.; Marucco, P.; Balafoutis, A.T.; Balsari, P. Spray drift generated in vineyard during under-row weed control and suckering: Evaluation of direct and indirect drift-reducing techniques. *Sustainability* **2020**, *12*, 5068. <https://doi.org/10.3390/su12125068>.
 26. Kasner, E.J.; Fenske, R.A.; Hoheisel, G.A.; Galvin, K.; Blanco, M.N.; Seto, E.Y.; Yost, M.G. Spray drift from three airblast sprayer technologies in a modern orchard work environment. *Ann. Work. Expo. Health* **2020**, *64*, 25–37.
 27. Tsakirakis, A.N.; Kasiotis, K.M.; Glass, C.R.; Charistou, A.N.; Anastasiadou, P.; Gerritsen-Ebben, R.; Machera, K. Sequential indoor use of pesticides: Operator exposure via deposit transfer from sprayed crops and contaminated application equipment. *Appl. Sci.* **2022**, *12*, 3909. <https://doi.org/10.3390/app12083909>.
 28. European Commission. Directive 2009/128/EC of the European parliament and the council of 21 October 2009 establishing a framework for community action to achieve the sustainable use of pesticides. *Off. J. Eur. Union L* **2009**, *309*, 71–86.
 29. European Commission. Directive 2006/42/EC of the European parliament and the council of 17 May 2006 on machinery, and amending Directive 95/16/EC (recast). *Off. J. Eur. Union L* **2006**, *157*, 24–86.
 30. European Commission. Farm to Fork Strategy—for a Fair, Healthy and Environmentally-Friendly Food System. Available Online: https://ec.europa.eu/food/farm2fork_en (accessed on 9 May 2022).
 31. Pascuzzi, S.; Santoro, F.; Manetto, G.; Cerruto, E. Study of the correlation between foliar and patternator deposits in a “tendone” vineyard. *Agric. Eng. Int.* **2018**, *20*, 97–107.

32. Grella, M.; Miranda- Fuentes, A.; Marucco, P.; Balsari, P.; Gioelli, F. Development of drift-reducing spouts for vineyard pneumatic sprayers: Measurement of droplet size spectra generated and their classification. *Appl. Sci.* **2020**, *10*, 7826. <https://doi.org/10.3390/app10217826>.
33. Vereecke, E.; Langenakens, J.; De Moor, A.; Pieters, M.; Jaeken, P. The Air Distribution Generated by Air-Assisted Orchard Sprayers. In Proceedings of the 52nd International Symposium on Crop Protection, Gent, Belgium, 9 May 2000; Volume 65, pp. 991–1000.
34. Dekeyser, D.; Duga, A.T.; Verboven, P.; Endalew, A.M.; Hendrickx, N.; Nuyttens, D. Assessment of orchard sprayers using laboratory experiments and computational fluid dynamics modelling. *Biosyst. Eng.* **2013**, *114*, 157–169.
35. Salcedo, R.; Fonte, A.; Grella, M.; Garcerá, C.; Chueca, P. Blade pitch and air outlet width effects on the airflow generated by an airblast sprayer with wireless remote-controlled axial fan. *Comput. Electron. Agric.* **2021**, *190*, 106428. <https://doi.org/10.1016/j.compag.2021.106428>.
36. Grella, M.; Marucco, P.; Zwertvaegher, I.; Gioelli, F.; Bozzer, C.; Biglia, A.; Manzone, M.; Caffini, A.; Fountas, S.; Nuyttens, D.; et al. The effect of fan setting, air-conveyor orientation and nozzle configuration on airblast sprayer efficiency: Insights relevant to trellised vineyards. *Crop. Prot.* **2022**, *155*, 105921. <https://doi.org/10.1016/j.cropro.2022.105921>.
37. Kümmel, K.; Goehlich, H.; Westphal, O. Development of practice-oriented control test methods for orchard spray machines by means of a vertical test stand. In *Air-Assisted Spraying in Crop Protection, Proceedings of the AAB-BCPC Conference, Swansea, UK, 1 January 1991*; Lavers, A., Herrington, P., Southcombe, E.S.E., Eds.; British Crop Protection Council Monograph: Farnham, UK, 1991; Volume 46, pp. 27–33.
38. van de Zande, J.C.; Schlepers, M.; Hofstee, J.W.; Michielsen, J.M.G.P.; Wenneker, M. Characterization of the Air-Flow and the Liquid Distribution of Orchard Sprayers. In Proceedings of the SUPROFRUIT 2017—14th Workshop on Spray Application Techniques in Fruit Growing, Hasselt, Limburg, Belgium, 1–12 May 2017.
39. Hoheisel, G.-A.; Khot, L.R.; Moyer, M.; Castagnoli, S. Six steps to calibrate and optimize airblast sprayers for orchards and vineyards. *Pac. North West Ext. Publ.* **2021**, *PNW749*, 13.
40. Biocca, M.; Mattera, E.; Imperi, G. A New Vertical Patternator to Evaluate the Distribution Quality of Vineyards and Orchards Sprayers. In Proceedings of the FRUTIC 05, Information and Technology for Sustainable Fruit and Vegetable Production, Montpellier, France, 12–16 September 2005.
41. Garcerá, C.; Moltó, E.; Chueca, P. Factors influencing the efficacy of two organophosphate insecticides in controlling California red scale, *Aonidiella aurantii* (Maskell). A basis for reducing spray application volume in Mediterranean conditions. *Pest Manag. Sci.* **2014**, *70*, 28–38. <https://doi.org/10.1002/ps.3515>.
42. Michael, C.; Gil, E.; Gallart, M.; Stavrinides, M.C. Influence of spray technology and application rate on leaf deposit and ground losses in mountain viticulture. *Agriculture* **2020**, *10*, 615. <https://doi.org/10.3390/agriculture10120615>.
43. Fonte, A.; Garcerá, C.; Tena, A.; Chueca, P. Volume rate adjustment for pesticide applications against *Aonidiella aurantii* in citrus: Validation of CitrusVol in the growers' practice. *Agronomy* **2021**, *11*, 1350. <https://doi.org/10.3390/agronomy11071350>.
44. Garcerá, C.; Doruchowski, G.; Chueca, P. Harmonization of plant protection products dose expression and dose adjustment for high growing 3D crops: A review. *Crop Prot.* **2021**, *140*, 105417. <https://doi.org/10.1016/j.cropro.2020.105417>.
45. Xun, L.; Garcia-Ruiz, F.; Fabregas, F.X.; Gil, E. Pesticide dose based on canopy characteristics in apple trees: Reducing environmental risk by reducing the amount of pesticide while maintaining pest and disease control efficacy. *Sci. Total Environ.* **2022**, *826*, 154204. <https://doi.org/10.1016/j.scitotenv.2022.154204>.
46. Salyani, M. Optimization of deposition efficiency for airblast sprayers. *Trans. ASAE* **2000**, *43*, 247–253. <https://doi.org/10.13031/2013.2699>.
47. Farooq, M.; Landers, A. Interactive Effects of Air, Liquid and Canopies on Spray Patterns of Axial-Flow Sprayers. In Proceedings of the ASAE Annual International Meeting, Ottawa, ON, Canada, 1–4 August 2004. <https://doi.org/10.13031/2013.16120>.
48. Farooq, M.; Salyani, M. Modelling of spray penetration and deposition on citrus tree canopies. *Trans. ASAE* **2004**, *47*, 619–627. <https://doi.org/10.13031/2013.16091>.
49. Vujčić, B.; Tadić, V.; Marković, M.; Lukinac-Čačić, J.; Stošić, M.; Plaščak, I. Impact of technical spraying factors on vertical liquid distribution with Agromehanika AGP 440 axial fan sprayer. *Tech. Gaz.* **2015**, *22*, 367–373.
50. De Moor, A.; Langenakens, J.; Vereecke, E.; Jaeken, P.; Lootens, P.; Vandecasteele, P. Image analysis of water sensitive paper as a tool for the evaluation of spray distribution of orchard sprayers. *Asp. Appl. Biol. Int. Adv. Pestic. Appl.* **2000**, *57*, 329–341.
51. Mangado, J.; Arazuri, S.; Arnal, P.; Jarén, C.; López, A. Measuring the accuracy of a pesticide treatment by an image analyzer. *Procedia Technol.* **2013**, *8*, 498–502.
52. Salyani, M.; Zhu, H.; Sweeb, R.D.; Pai, N. Assessment of spray distribution with water-sensitive paper. *Agric. Eng. Int. CIGR J.* **2013**, *15*, 101–111.
53. Miralles, A.; Gorretta, N.; Dusserre-Bresson, L.; Sevilla, F.; Miller, P.C.H.; Walklate, P.; Van Zuidam, R.P.; Porskamp, H.A.J.; Ganzelmeier, H.; Rietz, S.; et al. Results of a European programme to compare methods used to test orchard sprayers. *EPPO Bull* **1996**, *26*, 59–68. <https://doi.org/10.1111/j.1365-2338.1996.tb01529.x>.
54. Tekeloglu, O.; Parkin, S. A new technique for the measurement of the spatial distribution of sprays in air-jets. *Asp. Appl. Biol. Int. Adv. Pestic. Appl.* **2002**, *66*, 435–442.
55. Miller, D.R.; Yendol, W.E.; McManus, M.L. On the field sampling of pesticide spray distributions using Teflon spheres and flat cards. *J. Environ. Sci. Health. B* **1992**, *27*, 185–208.

56. Pergher, G. Recovery rate of tracer dyes used for spray deposit assessment. *Trans. ASAE* **2001**, *44*, 787–794. <https://doi.org/10.13031/2013.6240>.
57. Menesatti, P.; Biocca, M.; D'Andrea, S.; Pincu, M. Thermography to analyze distribution of agricultural sprayers. *Quant. Infrared Thermogr. J.* **2008**, *5*, 81–96.
58. Pergher, G.; Gubiani, R. A comparison of methods for assessing vertical spray distributions from air-assisted sprayers. *EPPO Bull* **1997**, *27*, 227–234.
59. Khot, L.R.; Ehsani, R.; Albrigo, G.; Landers, A.; Larbi, P. Spray pattern investigation of an axial-fan airblast precision sprayer using a modified vertical patternator. *Appl. Eng. Agric.* **2012**, *28*, 647–654.
60. Khot, L.R.; Ehsani, R.; Albrigo, G.; Larbi, P.; Landers, A.; Campoy, J.; Wellington, C. Air-assisted sprayer adapted for precision horticulture: Spray patterns and deposition assessments in small-sized citrus canopies. *Biosyst. Eng.* **2012**, *113*, 76–85.
61. Gil, E.; Landers, A.; Gallart, M.; Llorens, J. Development of two portable patternators to improve drift control and operator training in the operation of vineyard sprayers. *Span. J. Agric. Res.* **2013**, *11*, 615–625. <https://doi.org/10.5424/sjar/20131113-3638>.
62. Allochis, D.; Balsari, P.; Tamagnone, M.; Marucco, P.; Vai, P.; Bozzer, C. Performances Evaluation of Different Vertical Patternators. In Proceedings of the Fifth European Workshop on Standardised Procedure for the Inspection of Sprayers—SPISE 5, Montpellier, France, 15–17 October 2014.
63. Biocca, M.; Gallo, P. Comparison between horizontal and vertical lamellate patternators for air-blast sprayers. *Open Agric. J.* **2014**, *8*, 12–17.
64. Pergher, G. Field evaluation of a calibration method for air-assisted sprayers involving the use of a vertical patternator. *Crop. Prot.* **2004**, *23*, 437–446. <https://doi.org/10.1016/j.cropro.2003.09.015>.
65. Rathnayake, A.P.; Chandel, A.K.; Schrader, M.J.; Hoheisel, G.A.; Khot, L.R. Spray patterns and perceptive canopy interaction assessment of commercial airblast sprayers used in Pacific Northwest perennial specialty crop production. *Comput. Electron. Agric.* **2021**, *184*, 106097. <https://doi.org/10.1016/j.compag.2021.106097>.
66. Bahlol, H.Y.; Chandel, A.K.; Hoheisel, G.A.; Khot, L.R. Smart spray analytical system for orchard sprayer calibration: A-proof-of-concept and preliminary results. *Trans. ASABE* **2019**, *63*, 29–35. <https://doi.org/10.13031/trans.13196>.
67. Bahlol, H.Y.; Chandel, A.K.; Hoheisel, G.A.; Khot, L.R. The smart spray analytical system: Developing understanding of output air-assist and spray patterns from orchard sprayers. *Crop. Prot.* **2020**, *127*, 104977. <https://doi.org/10.1016/j.cropro.2019.104977>.
68. Tamagnone, M.; Calvo, A.; Savoia, S. Development of a software for supporting the adjustment of vertical spray pattern of air assisted sprayers. In Proceedings of the SUPROFRUIT 2015—13th Workshop on Spray Application in Fruit Growing, Lindau/Lake Costance, Germany, 15–18 July 2015.
69. Food and Agriculture Organization of United Nations. FAOSTAT. Available Online: <https://www.fao.org/faostat/en/#data> (accessed on 9 May 2022).
70. Fox, R.D.; Derksen, R.C.; Zhu, H.; Brazee, R.D.; Svensson, S.A. A history of air-blast sprayer development and future prospects. *Trans. ASABE* **2008**, *51*, 405–410. <https://doi.org/10.13031/2013.24375>.
71. Miller, P.R.; Salyani, M.; Hiscox, A.L. Remote Measurement of Spray Drift from Orchard Sprayers Using LIDAR. In Proceedings of the ASAE Annual International Meeting, Las Vegas, NV, USA, 27–30 July 2003. <https://doi.org/10.13031/2013.13729>.
72. Hong, S.-W.; Park, J.; Jeong, H.; Lee, S.; Choi, L.; Zhao, L.; Zhu, H. Fluid dynamic approaches for prediction of spray drift from ground pesticide applications: A review. *Agronomy* **2021**, *11*, 1182. <https://doi.org/10.3390/agronomy11061182>.
73. Salyani, M.; McCoy, C.W. Deposition of different spray volumes on citrus trees. *Proc. Fa. State Hort. Soc.* **1989**, *102*, 32–36.
74. Whitney, J.; Salyani, M.; Churchill, D.; Knapp, J.; Whiteside, J. A field investigation to examine the effects of sprayer type, ground speed, and volume rate on spray deposition in Florida citrus. *J. Agric. Eng. Res.* **1989**, *42*, 275–283.
75. Hoffmann, W.C.; Salyani, M. Spray deposition on citrus canopies under different meteorological conditions. *Trans. ASAE* **1996**, *39*, 17–22. <https://doi.org/10.13031/2013.27475>.
76. Derksen, R.C.; Krause, C.R.; Fox, R.D.; Brazee, R.D.; Zondag, R. Effect of application variables on spray deposition, coverage, and ground losses in nursery tree applications. *J. Environ. Hort.* **2006**, *24*, 45–52. <https://doi.org/10.24266/0738-2898-24.1.45>.
77. Miranda-Fuentes, A.; Rodríguez-Lizana, A.; Gil, E.; Agüera-Vega, J.; Gil-Ribes, J.A. Influence of liquid-volume and airflow rates on spray application quality and homogeneity in super-intensive olive tree canopies. *Sci. Total Environ.* **2015**, *537*, 250–259. <https://doi.org/10.1016/j.scitotenv.2016.06.013>.
78. Grella, M.; Marucco, P.; Balsari, P. Toward a new method to classify the airblast sprayers according to their potential drift reduction: Comparison of direct and new indirect measurement methods. *Pest Manag. Sci.* **2019**, *75*, 2219–2235. <https://doi.org/10.1002/ps.5354>.
79. Nuyttens, D.; Baetens, K.; De Schampheleire, M.; Sonck, B. Effect of nozzle type, size and pressure on spray droplet characteristics. *Biosyst. Eng.* **2007**, *97*, 333–345. <https://doi.org/10.1016/j.biosystemseng.2007.03.001>.
80. Frost, K.R.; Ware, G.W. Pesticide drift from aerial and ground applications. *Agric. Eng.* **1970**, *51*, 460–464.
81. Bird, S.L.; Esterly, D.M.; Perry, S.G. Atmospheric pollutants and trace gases. Off-target deposition of pesticides from agricultural aerial spray applications. *J. Environ. Qual.* **1996**, *25*, 1095–1104.
82. Li, T.; Qi, P.; Wang, Z.; Xu, S.; Huang, Z.; Han, L.; He, X. Evaluation of the effects of airflow distribution patterns on deposit coverage and spray penetration in multi-unit air-assisted sprayer. *Agronomy* **2022**, *12*, 944. <https://doi.org/10.3390/agronomy12040944>.
83. Pergher, G.; Gubiani, R.; Gasparinetti, P.; Del Cont Bernard, D. Voluntary testing of plant protection equipment in Northern Italy. *Acta Hort.* **1994**, *372*, 59–66. <https://doi.org/10.17660/ActaHortic.1994.372.7>.

84. Schmidt, K.; Koch, H. Einstellung von Sprühgeräten und Verteilung von Pflanzenschutzmittelbelagen in Obstanlagen (Adjustment of spraying equipment and distribution of pesticide deposits in fruit production). *Nachrichtenbl. Dtsch. Pflanzenschutzd.* **1995**, *47*, 161–167.
85. Heijne, B.; Wenneker, M.; van de Zande, J.C. Air inclusion nozzles don't reduce pollution of surface water during orchard spraying in The Netherlands. International advances in pesticide application. *Asp. Appl. Biol. Int. Adv. Pestic. Appl.* **2002**, *66*, 193–199.
86. Derksen, R.C.; Zhu, H.; Fox, R.D.; Brazee, R.D.; Krause, C.R. Coverage and drift produced by air induction and conventional hydraulic nozzles used for orchard applications. *Trans. ASABE* **2007**, *50*, 1493–1501. <https://doi.org/10.13031/2013.23941>.
87. Sesah, E.M.E. Study of effects of forward speed and nozzle types on the spray characteristics of air assistance hydraulic sprayer. *Misr J. Agric. Eng.* **2007**, *24*, 75–87.
88. Lešnik, M.; Stajniko, D.; Vajs, S. Interactions between spray drift and sprayer travel speed in two different apple orchard training systems. *Int. J. Environ. Sci. Technol.* **2015**, *12*, 3017–3028. <https://doi.org/10.1007/s13762-014-0724-7>.
89. Fox, R.D.; Reichard, D.L.; Brazee, R.L. A model study of the effect of wind on air sprayer jets. *Trans. ASAE* **1985**, *28*, 83–88. <https://doi.org/10.13031/2013.32207>.
90. Pergher, G.; Balsari, P.; Cerruto, E.; Vieri, M. The relationship between vertical spray patterns from air-assisted sprayers and foliar deposits in vine canopies. *Asp. Appl. Biol. Int. Adv. Pestic. Appl.* **2002**, *66*, 323–330.
91. Kaul, P.H.; Henning, H.; Gebauer, S. Nutzung von Vertikalverteilungs-Prüfständen zur Beurteilung von Sprühgeräten im Obstbau (Use of vertical patternators for assessment of orchard sprayers). *Nachrichtenbl. Deut. Pflanzenschutzd.* **2003**, *55*, 101–109.
92. Pascuzzi, S. Outcomes on the spray profiles produced by the feasible adjustments of commonly used sprayers in “tendone” vineyards of Apulia (southern Italy). *Sustainability* **2016**, *8*, 1307. <https://doi.org/10.3390/su8121307>.
93. Garcerá, C. Racionalización de las aplicaciones de productos fitosanitarios para el control de *Aonidiella aurantii* Maskell (Hemiptera: Diaspididae) en cítricos. Ph.D. Thesis, Universitat Politècnica de València, Valencia, Spain, 30 July 2013. (In Spanish)
94. Cerruto, E.; Manetto, G.; Longo, D.; Failla, S.; Papa, R. A model to estimate the spray deposit by simulated water sensitive papers. *Crop. Prot.* **2019**, *124*, 104861. <https://doi.org/10.1016/j.cropro.2019.104861>.