

AperTO - Archivio Istituzionale Open Access dell'Università di Torino

Modelling the photochemical fate of ibuprofen in surface waters

This is the author's manuscript

Original Citation:

Availability:

This version is available <http://hdl.handle.net/2318/94975> since

Published version:

DOI:10.1016/j.watres.2011.10.014

Terms of use:

Open Access

Anyone can freely access the full text of works made available as "Open Access". Works made available under a Creative Commons license can be used according to the terms and conditions of said license. Use of all other works requires consent of the right holder (author or publisher) if not exempted from copyright protection by the applicable law.

(Article begins on next page)



UNIVERSITÀ DEGLI STUDI DI TORINO

This Accepted Author Manuscript (AAM) is copyrighted and published by Elsevier. It is posted here by agreement between Elsevier and the University of Turin. Changes resulting from the publishing process - such as editing, corrections, structural formatting, and other quality control mechanisms - may not be reflected in this version of the text. The definitive version of the text was subsequently published in

D. Vione, P. R. Maddigapu, E. De Laurentiis, M. Minella, M. Pazzi, V. Maurino, C. Minero, S. Kouras, C. Richard. Modelling the Photochemical Fate of Ibuprofen in Surface Waters. *Wat. Res.* **2011**, *45*, 6725-6736.

You may download, copy and otherwise use the AAM for non-commercial purposes provided that your license is limited by the following restrictions:

- (1) You may use this AAM for non-commercial purposes only under the terms of the CC-BY-NC-ND license.
- (2) The integrity of the work and identification of the author, copyright owner, and publisher must be preserved in any copy.
- (3) You must attribute this AAM in the following format:

D. Vione, P. R. Maddigapu, E. De Laurentiis, M. Minella, M. Pazzi, V. Maurino, C. Minero, S. Kouras, C. Richard. Modelling the Photochemical Fate of Ibuprofen in Surface Waters. *Wat. Res.* **2011**, *45*, 6725-6736.

DOI: 10.1016/j.watres.2011.10.014 (<http://www.elsevier.com/locate/watres>)

MODELLING THE PHOTOCHEMICAL FATE OF IBUPROFEN IN SURFACE WATERS

Davide Vione,^{a,b,*} Pratap Reddy Maddigapu,^a Elisa De Laurentiis,^a Marco Minella,^a Marco Pazzi,^a Valter Maurino,^a Claudio Minero,^a Sofia Kouras,^{c,d} Claire Richard^{c,d}

^a Dipartimento di Chimica Analitica, Università di Torino, Via P. Giuria 5, 10125 Torino, Italy. <http://www.environmentalchemistry.unito.it>

^b Centro Interdipartimentale NatRisk, Università di Torino, Via Leonardo da Vinci 44, 10095 Grugliasco (TO), Italy. <http://www.natrisk.org>

^c Clermont Université, Université Blaise Pascal, Laboratoire de Photochimie Moléculaire et Macromoléculaire, BP 10448, F-63000, Clermont-Ferrand, France.

^d CNRS, UMR 6505, Laboratoire de Photochimie Moléculaire et Macromoléculaire, BP80026 F-63171 Aubière Cedex, France.

* Corresponding author. Tel. +39-011-6705296. Fax +39-011-6707615. davide.vione@unito.it
http://chimica.campusnet.unito.it/do/docenti.pl/Show?_id=dvione

Abstract

We show that the main photochemical processes involved in the phototransformation of anionic ibuprofen (IBP) in surface waters are the reaction with $\bullet\text{OH}$, the direct photolysis and possibly the reaction with the triplet states of chromophoric dissolved organic matter (${}^3\text{CDOM}^*$). These conclusions were derived by use of a model of surface-water photochemistry, which adopted measured parameters of photochemical reactivity as input data. The relevant parameters are the polychromatic UVB photolysis quantum yield ($\Phi_{\text{IBP}} = 0.33 \pm 0.05$, $\mu \pm \sigma$), the reaction rate constant with $\bullet\text{OH}$ ($k_{\text{IBP},\bullet\text{OH}} = (1.0 \pm 0.3) \cdot 10^{10} \text{ M}^{-1} \text{ s}^{-1}$), the ${}^1\text{O}_2$ rate constant ($k_{\text{IBP},{}^1\text{O}_2} = (6.0 \pm 0.6) \cdot 10^4 \text{ M}^{-1} \text{ s}^{-1}$), while the reaction with $\text{CO}_3^{\bullet-}$ can be neglected. We adopted anthraquinone-2-sulphonate (AQ2S) and riboflavin (Ri) as CDOM proxies and the reaction rate constants with the respective triplet states were $k_{\text{IBP},{}^3\text{AQ2S}^*} = (9.7 \pm 0.2) \cdot 10^9 \text{ M}^{-1} \text{ s}^{-1}$ and $k_{\text{IBP},{}^3\text{Ri}^*} = 4.5 \cdot 10^7 \text{ M}^{-1} \text{ s}^{-1}$. The reaction with ${}^3\text{CDOM}^*$ can be an important IBP sink if its rate constant is comparable to that of ${}^3\text{AQ2S}^*$, while it is unimportant if the rate constant is similar to the ${}^3\text{Ri}^*$ one. The photochemical pathways mainly lead to the transformation (oxidation and/or shortening) of the propionic lateral chain of IBP, which

appears to be significantly more reactive than the isobutyl one. Interestingly, none of the detected intermediates was produced by substitution on the aromatic ring.

Keywords: pharmaceuticals; PCCPs; non-steroidal anti-inflammatory drug; surface-water photochemistry; sensitised phototransformation; hydroxyl radical; singlet oxygen.

Introduction

Ibuprofen (2-(4-(2-methylpropyl)phenyl)propanoic acid, hereafter IBP) is a non-steroidal anti-inflammatory drug that is widely used nowadays as the active principle of many “over the counter” pharmaceutical products. Excretion by humans after partial metabolism and incorrect drug disposal are two important pathways of IBP to sewage waters. For instance, it has been the sixth most abundant pharmaceutical detected in the influent flow of wastewater treatment plants (WWTPs) in Italy (Castiglioni et al., 2006). Although it is susceptible to biodegradation (Tiehm et al., 2011; de Graaf et al., 2011), IBP is only partially removed by WWTPs (Oulton et al., 2010; Morasch et al., 2010) and the treatment efficiency undergoes a considerable decrease during the winter months (Castiglioni et al., 2006; Santos et al., 2009), when the IBP environmental inputs tend to increase considerably (Daneshvar et al., 2010). The combination of widespread use and incomplete WWTP elimination results into an extensive occurrence of IBP in surface waters. Indeed, this compound has been detected in water systems all over the world (Zuccato et al., 2005; Zhao et al., 2009; Yu et al., 2009; Pailler et al., 2009; Moldovan et al., 2009; Fernandez et al., 2010; Camacho-Munoz et al., 2010; Loos et al., 2010; Teijon et al., 2010; Zhao et al., 2010; Helenkar et al., 2010; Waiser et al., 2011; Wang et al., 2011; Lewandowski et al., 2011).

IBP has been found to accumulate in fatty fish tissues and muscles (Zhang et al., 2010) and to cause disturbance to both amphipoda (De Lange et al., 2009) and cnidaria (Quinn et al., 2008). IBP effects can be increased when it is present in mixture with other pharmaceuticals. Negative effects at environmentally significant levels have been observed for both cnidaria (Quinn et al., 2009) and human embryonic cells (Pomati et al., 2006). The latter finding is potentially of very high concern when considering the occurrence of IBP in drinking water, at very variable levels depending on the location (Kleywegt et al., 2011; Valcarcel et al., 2011).

Biodegradation and phototransformation are potentially important transformation processes for IBP in surface waters (Lin and Reinhard, 2005). Phototransformation might involve direct

photolysis and indirect reaction with transient species ($\bullet\text{OH}$, $\text{CO}_3^{\bullet-}$, $^1\text{O}_2$, $^3\text{CDOM}^*$) generated by CDOM, nitrite and nitrate under irradiation (Hoigné, 1990; Peuravuori and Pihlaja, 2009). As far as the direct photolysis is concerned, IBP is a poor absorber of sunlight (Lin and Reinhard, 2005; Peuravuori and Pihlaja, 2009) but its highest-wavelength absorption band (maximum around 265 nm) is characterised by a quite efficient photolysis (Yuan et al., 2009). Poor sunlight absorption and elevated photolysis quantum yield are contrasting issues as far as the environmental importance of direct photolysis is concerned. A similar case holds for the herbicide 2-methyl-4-chlorophenoxy acetic acid (MCPA), and we have recently found that MCPA direct photolysis can be a significant process but it is highly influenced by the environmental variables (Vione et al., 2010). The available literature data do not allow a clear assessment of the importance of the direct photolysis as a potential transformation pathway for IBP in surface waters (Packer et al., 2003; Lin and Reinhard, 2005; Matamoros et al., 2009; Peuravuori and Pihlaja, 2009).

We have recently developed a model approach to describe the transformation kinetics of dissolved compounds as a function of water chemical composition, column depth and photochemical reactivity (*i.e.* direct photolysis quantum yield and reaction rate constants with $\bullet\text{OH}$, $\text{CO}_3^{\bullet-}$, $^1\text{O}_2$ and $^3\text{CDOM}^*$) (Maddigapu et al., 2011). Such an approach was able to effectively predict field data in the case of 2,4-dichloro-6-nitrophenol in the Rhône delta lagoons (Chiron et al., 2007). The goal of the present paper is to assess the role of direct and indirect photochemistry in the degradation of IBP in surface waters. To this purpose, we combine a kinetic study of IBP transformation by direct photolysis and reaction with $\bullet\text{OH}$, $\text{CO}_3^{\bullet-}$, $^1\text{O}_2$ and $^3\text{CDOM}^*$, with a photochemistry model. The latter enables the prediction of IBP transformation kinetics as a function of photoreactivity data and of key environmental variables.

IBP phototransformation intermediates, formed in the first step of the environmentally most significant processes were also identified. IBP has $\text{pK}_a = 4.4$ (Martell et al., 1997) and its anionic form would prevail under most conditions that are relevant to surface waters. In this work, irradiation was carried out at both pH 2 and 8 where the neutral and the anionic IBP forms prevail, respectively.

Experimental section

Reagents and materials

Ibuprofen (IBP, purity grade 98%), anthraquinone-2-sulphonic acid, sodium salt (AQ2S, 97%), furfuryl alcohol (98%), NaNO_3 (>99%), NaHCO_3 (98%), anhydrous Na_2SO_4 (99%), NaCl (99.5%),

HClO₄ (70%) and H₃PO₄ (85%) were purchased from Aldrich, NaOH (99%), methanol and 2-propanol (both LiChrosolv gradient grade) and dichloromethane (GC Suprasolv) from VWR Int., Rose Bengal (RB) from Alfa Aesar, riboflavin (>98%) from Sigma.

Irradiation experiments

Solutions to be irradiated (5 mL) were placed inside Pyrex glass cells (4.0 cm diameter, 2.3 cm height, 295 nm cut-off wavelength) and magnetically stirred during irradiation. Irradiation of IBP + nitrate to study reactions with $\bullet\text{OH}$ and $\text{CO}_3^{\bullet-}$, and irradiation of IBP alone to study the direct photolysis were carried out under a Philips TL 01 UV-Vis lamp, with emission maximum at 313 nm and $3.0 \pm 0.2 \text{ W m}^{-2}$ UV irradiance in the 300-400 nm range, measured with a power meter by CO.FO.ME.GRA. (Milan, Italy) equipped with a UV-sensitive probe. The incident photon flux in solution was actinometrically determined using the ferrioxalate method (Kuhn et al., 2004). By knowing, as a function of the wavelength, the fraction of radiation absorbed by $\text{Fe}(\text{C}_2\text{O}_4)_3^{3-}$, the quantum yield of Fe^{2+} photoproduction and the shape of the lamp spectrum (*vide infra*), it is possible to use the measured formation rate of Fe^{2+} to fix the value of the incident spectral photon flux density $p^\circ(\lambda)$. The photon flux of the UV-Vis lamp between 300 and 500 nm was $P_o = \int_{\lambda} p^\circ(\lambda) d\lambda = 2.0 \cdot 10^{-5} \text{ Einstein L}^{-1} \text{ s}^{-1}$. The transformation of IBP photosensitised by AQ2S

was studied under a Philips TL K05 UVA lamp, with emission maximum at 365 nm, 28 W m^{-2} UV irradiance (300-400 nm), and $2.1 \cdot 10^{-5} \text{ Einstein L}^{-1} \text{ s}^{-1}$ incident photon flux in solution between 300 and 500 nm. The photodegradation of IBP sensitised by Rose Bengal (RB) via $^1\text{O}_2$ was studied under a Philips TL D 18W/16 yellow lamp, with emission maximum at 545 nm and 11 W m^{-2} irradiance in the visible, measured with the CO.FO.ME.GRA. power meter equipped with a probe sensitive to visible radiations.

The mixtures IBP-riboflavin were irradiated at 365 nm in a cuvette in parallel beam, using a Xenon lamp (1600 W) equipped with a Bausch and Lomb monochromator. The incident photon flux in solution, measured by ferrioxalate actinometry, was $1.2 \times 10^{-6} \text{ Einstein L}^{-1} \text{ s}^{-1}$.

The choice of the lamps had the purpose of exciting each photosensitiser as selectively as possible. The direct photolysis of IBP was studied under a lamp having maximum emission in the UVB region, upon consideration of the IBP absorption spectrum. The emission spectra of the lamps were taken with an Ocean Optics SD 2000 CCD spectrophotometer and normalised to the actinometry results, also taking into account the absorbance of the Pyrex glass walls of the irradiation cells. Note that, irrespective of the presence of the Pyrex glass, no lamp emitted radiation

below 300 nm. The absorption spectra of the relevant compounds were taken with a Varian Cary 100 Scan UV-Vis spectrophotometer. The various emission and absorption spectra are reported in Figure 1.

Monitoring of IBP transformation

After the scheduled irradiation time, the cells were withdrawn from the lamp and the irradiated solutions were analysed by high-performance liquid chromatography (HPLC-UV) to monitor the time evolution of IBP. The adopted Merck-Hitachi instrument was equipped with an autosampler AS2000A (100 μ L sample volume), pumps L-6200 and L-6000 for high-pressure gradients, a reverse-phase column Merck LiChrocart RP-C18 packed with LiChrospher 100 RP-18 (125 mm \times 4.6 mm \times 5 μ m), and a UV-Vis detector L-4200 (detection wavelength 279 nm). It was adopted an isocratic elution with a 80:20 mixture of CH₃OH:aqueous H₃PO₄ (pH 2.8) at a flow rate of 1.0 mL min⁻¹. The retention time of IBP was 3.3 minutes, the column dead time 0.90 min.

The time evolution of furfuryl alcohol to quantify the formation rate of ¹O₂ under the yellow lamp was also monitored by HPLC-UV, as reported in Minella et al. (2011).

Identification of IBP transformation intermediates

Intermediate identification was carried out with gas chromatography coupled with mass spectrometry. To this purpose, aqueous solutions after irradiation were extracted with 3 mL dichloromethane, dehumidified with anhydrous Na₂SO₄ and evaporated to dryness. Each sample was reconstructed with 100 μ L dichloromethane. The solution was transferred into a vial and injected into a capillary gas chromatograph (Agilent 6890) coupled with a mass spectrometer (Agilent 5973 inert). The injection system used was a Gerstel CIS4 PTV. Initial injection temperature was 40 °C, programmed at 5 °C/s; final temperature was 320 °C, held for 9 min. The injection volume was 2 μ l in the splitless mode. The capillary column used was a HP-5MS, 30 m \times 0.25 mm \times 0.25 μ m film thickness. Initial column temperature was 40 °C and was increased by 15 °C/min to 300 °C. The carrier gas was ultrapure He (1.0 mL/min; SIAD, Bergamo, Italy). The ionization source worked in the electronic impact (EI) mode and the mass spectrometer worked in the Scan mode from 44 to 450 Th. Identification of spectra was performed by using the Wiley 7n library (Agilent Part No. G1035B).

Kinetic data treatment

Reaction rates were determined by fitting the time evolution data of IBP with pseudo-first order equations of the form $C_t = C_o \exp(-k t)$, where C_t is the concentration of IBP at the irradiation time t , C_o its initial concentration and k the pseudo-first order degradation rate constant. The initial degradation rate is $R_{DCNP} = k C_o$. The reported errors on the rates ($\pm\sigma$) were derived by curve fitting and depend on the scattering of the experimental data around the fitting curve. The reproducibility of repeated runs was around 10-15%. The data plots, the fits and the numerical integrations to determine the absorbed photon fluxes were all carried out with the Fig.P software package (BIOSOFT, Cambridge, UK).

Results and discussion

Kinetics of IBP photochemical transformation

Direct photolysis. IBP (initial concentration 20 μM) was irradiated under the TL 01 lamp (emission maximum at 313 nm, see Figure 1) at pH 2 and 8. The time evolution of IBP under the adopted experimental set-up is reported in Figure S1-SM (SM = Supplementary Material). Note that significant IBP degradation was obtained at both pH values and that the adopted lamp did not emit radiation below 300 nm. Such results are in agreement with Matamoros et al. (2009). The transformation rate was $Rate_{IBP} = (8.84 \pm 1.07) \cdot 10^{-11} \text{ M s}^{-1}$ at pH 2 and $(4.28 \pm 0.65) \cdot 10^{-11} \text{ M s}^{-1}$ at pH 8. The photon flux absorbed by IBP can be expressed as $P_a^{IBP} = \int_{\lambda} p^\circ(\lambda) [1 - 10^{-\varepsilon_{IBP}(\lambda)b[IBP]}] d\lambda$,

where $p^\circ(\lambda)$ is the incident spectral photon flux density of the lamp, $\varepsilon_{IBP}(\lambda)$ the molar absorption coefficient of IBP at pH 2 (neutral form) or pH 8 (anionic one, see Figure 1), b the optical path length in solution (0.4 cm), and $[IBP]$ the initial IBP concentration (20 μM). One gets $P_a^{IBP} = 8.73 \cdot 10^{-11} \text{ einstein L}^{-1} \text{ s}^{-1}$ at pH 2 and $1.30 \cdot 10^{-10} \text{ einstein L}^{-1} \text{ s}^{-1}$ at pH 8. From these data it is possible to obtain the polychromatic photolysis quantum yield of IBP, Φ_{IBP} , in the UVB region where the spectra of the lamp and IBP overlap. It is $\Phi_{IBP} = Rate_{IBP} (P_a^{IBP})^{-1} = 1.01 \pm 0.12$ at pH 2 and 0.33 ± 0.05 at pH 8 ($\mu \pm \sigma$). The latter datum is not too far from the quantum yield value of 0.2 obtained by Yuan et al. (2009) upon UVC irradiation of ibuprofen at pH 7. This high quantum yield of photolysis is consistent with the observed photodecarboxylation reactions (*vide infra*), which are reported to be very efficient photolysis pathways (Budac and Wan, 1992).

Reaction with $\bullet\text{OH}$. The reaction rate constant between IBP and $\bullet\text{OH}$ was determined upon competition kinetics with 2-propanol, using nitrate photolysis as the $\bullet\text{OH}$ source. The main reactions that are expected to take place in the system under consideration are the following (Mack and Bolton, 1999; Buxton et al., 1988):



Upon application of the steady-state approximation to $[\bullet\text{OH}]$, one gets the following expression for the initial transformation rate of IBP in the presence of 2-propanol:

$$\text{Rate}_{\text{IBP}} = \frac{R_{\bullet\text{OH}} \cdot k_3 \cdot [\text{IBP}]}{k_3 \cdot [\text{IBP}] + k_2 \cdot [\text{2-Propanol}]} \quad (4)$$

Figure 2 reports Rate_{IBP} as a function of the concentration of 2-propanol, upon irradiation of 10 mM NaNO_3 + 20 μM IBP at pH 2 (open squares) and at pH 8 (solid stars). For each pH value it is also reported the fit curve of equation (4) to the experimental data and the two 95% confidence bands (dotted for pH 2, dashed for pH 8).

It is evident that in both cases the alcohol inhibited the transformation of IBP, which is consistent with the scavenging of $\bullet\text{OH}$ in reaction (2). Under the adopted conditions (irradiation time up to 4 h) the rate of IBP direct photolysis could be neglected. The experimental rate data were fitted with equation (4), fixing the values of k_2 and $[\text{IBP}]$ and letting $R_{\bullet\text{OH}}$ and k_3 vary. From the fit we obtained $k_3 = (1.5 \pm 0.1) \cdot 10^{10} \text{ M}^{-1} \text{ s}^{-1}$ at pH 2 and $(1.0 \pm 0.3) \cdot 10^{10} \text{ M}^{-1} \text{ s}^{-1}$ at pH 8. These values are very near previous results by Parij et al. (1995). Packer et al. (2003) have obtained a somewhat different value, $k_3 = (6.5 \pm 0.2) \cdot 10^9 \text{ M}^{-1} \text{ s}^{-1}$ at pH 3.5 upon adoption of the Fenton reaction as $\bullet\text{OH}$ source. Considering that the Fenton process yields other oxidising species (*e.g.* ferryl) in addition to $\bullet\text{OH}$ (Bossmann et al., 2004; Prousek, 2007), which are usually less reactive than $\bullet\text{OH}$ itself, it cannot be excluded that use of the Fenton reaction could lead to a slight underestimation of the $\bullet\text{OH}$ rate constant.

Reaction with $\text{CO}_3^{\bullet-}$. A semi-quantitative assessment of the reactivity of a substrate with $\text{CO}_3^{\bullet-}$ can be carried out by studying the effect of bicarbonate on the transformation photoinduced by nitrate (Vione et al., 2009a). Figure 3 reports the initial transformation rate of 20 μM IBP upon irradiation of 10 mM NaNO_3 , with the addition of variable NaHCO_3 concentrations. In the presence of bicarbonate up to 10 mM, the solution pH gradually increased from 6.5 to 8.5. The trend of the IBP rate with irradiated nitrate is also shown upon addition of a phosphate buffer ($\text{NaH}_2\text{PO}_4 + \text{Na}_2\text{HPO}_4$). The total concentration of phosphate and the ratio $\text{NaH}_2\text{PO}_4 / \text{Na}_2\text{HPO}_4$ were chosen to have the same concentration values as for NaHCO_3 , and the same pH within ± 0.1 units. Finally, the transformation rate of IBP in the presence of NaHCO_3 without nitrate is also reported.

From Figure 3 it can be derived that: (i) the direct photolysis of IBP (irradiation without nitrate) was negligible under the adopted experimental conditions; (ii) bicarbonate inhibited the transformation of IBP upon nitrate irradiation, while phosphate had practically no effect. Nitrate photolysis yields $\bullet\text{OH}$ (reaction 1), and the addition of NaHCO_3 induces the production of $\text{CO}_3^{\bullet-}$ by reaction between the hydroxyl radical and $\text{HCO}_3^- / \text{CO}_3^{2-}$ (Buxton et al., 1988). There would be competition between IBP and $\text{HCO}_3^- / \text{CO}_3^{2-}$ for reaction with $\bullet\text{OH}$, but $\text{CO}_3^{\bullet-}$ (although it is less reactive than $\bullet\text{OH}$) could also contribute to the transformation of IBP. Vione et al. (2009a) have found that the formation rate of $\bullet\text{OH} + \text{CO}_3^{\bullet-}$ by irradiation of nitrate and bicarbonate is higher than the rate of $\bullet\text{OH}$ formation with nitrate alone. A likely explanation is that $\bullet\text{OH}$ and $\bullet\text{NO}_2$, photogenerated upon nitrate photolysis, undergo recombination to nitrate and H^+ when still in the solvent cage and before diffusing to the solution bulk. An excess bicarbonate could react with cage $\bullet\text{OH}$ and inhibit recombination, thereby enhancing the production of reactive species upon nitrate photolysis (reactions (5-8), Bouillon and Miller, 2005; Nissenson et al., 2010).

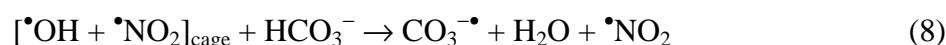
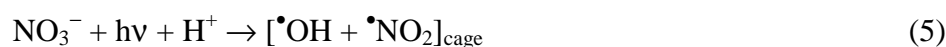

Because it induces the formation of a higher amount of a less reactive species, the addition of bicarbonate to irradiated nitrate enhances the transformation of the compounds that show a ratio of the rate constants with $\text{CO}_3^{\bullet-}$ and $\bullet\text{OH}$ higher than 0.01 (Vione et al., 2009a). The same compounds could also undergo significant transformation by $\text{CO}_3^{\bullet-}$ in the environment (Vione et al., 2009b). In contrast, inhibition of transformation by bicarbonate is observed for molecules that would also

undergo insignificant reaction with $\text{CO}_3^{\bullet-}$ in surface waters, such as 4-nitrophenol. However, considering that the addition of bicarbonate would also alter the solution pH, with implications for nitrate photolysis and possibly for substrate reactivity, enhancement or inhibition by bicarbonate are defined by comparison with phosphate buffers at the same pH values (Vione et al., 2009a).

In the case of IBP, the inhibition of transformation by bicarbonate compared to phosphate suggests that the reaction between IBP and $\text{CO}_3^{\bullet-}$ in surface waters would not be important (the relevant second-order rate constant is expected to be significantly below $10^8 \text{ M}^{-1} \text{ s}^{-1}$).

Reaction with $^1\text{O}_2$. Figure 4 reports the initial transformation rate of IBP, as a function of its initial concentration, upon irradiation of 10 μM Rose Bengal (RB) adopted as a source of $^1\text{O}_2$ (reaction (9); Miller, 2005). Irradiation was carried out only at pH 8, because at pH 2 RB is protonated and unable to absorb visible radiation to a significant extent. The reaction (10) between IBP and $^1\text{O}_2$ would be in competition with the thermal deactivation of singlet oxygen (reaction (11); Rodgers and Snowden, 1982):

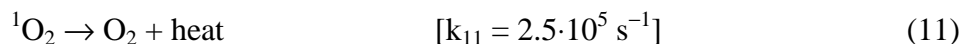
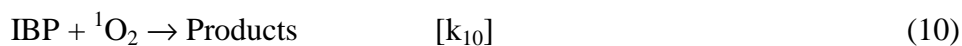

Upon application of the steady-state approximation to $^1\text{O}_2$ one gets the following expression for the initial transformation rate of IBP (Rate_{IBP}):

$$\text{Rate}_{\text{IBP}} = \frac{R_{^1\text{O}_2} \cdot k_{10} \cdot [\text{IBP}]}{k_{11} + k_{10} \cdot [\text{IBP}]} \quad (12)$$

where $R_{^1\text{O}_2}$ is the formation rate of $^1\text{O}_2$ by 10 μM RB under the adopted irradiation device. The measurement of $R_{^1\text{O}_2}$ was carried out upon irradiation at pH 8 of 10 μM RB + 0.1 mM furfuryl alcohol (FFA), which reacts with $^1\text{O}_2$ with a rate constant $k_{\text{FFA}} = 1.2 \cdot 10^8 \text{ M}^{-1} \text{ s}^{-1}$ (Haag et al., 1984). The initial transformation rate of FFA under the adopted conditions was $\text{Rate}_{\text{FFA}} = (1.26 \pm 0.06) \cdot 10^{-7} \text{ M s}^{-1}$. Photogenerated $^1\text{O}_2$ could undergo deactivation or reaction with FFA, and upon application of the steady-state approximation to $[^1\text{O}_2]$ one gets:

$$R_{^1\text{O}_2} = \text{Rate}_{\text{FFA}} \cdot \frac{k_{11} + k_{\text{FFA}} \cdot [\text{FFA}]}{k_{\text{FFA}} \cdot [\text{FFA}]} \quad (13)$$

From equation (13) one gets $R_{1O_2} = (2.75 \pm 0.13) \cdot 10^{-6} \text{ M s}^{-1}$. The linear trend of $Rate_{IBP}$ vs. $[IBP]$ in Figure 4 suggests that, in equation (12), $k_{10} [IBP] \ll k_{11}$. If this approximation holds, one gets $Rate_{IBP} = R_{1O_2} k_{10} (k_{11})^{-1} [IBP]$. From Figure 4 one obtains $Rate_{IBP} = (6.60 \pm 0.33) \cdot 10^{-7} [IBP]$, and from the known values of R_{1O_2} and k_{11} one gets $k_{10} = (6.00 \pm 0.58) \cdot 10^4 \text{ M}^{-1} \text{ s}^{-1}$ as the reaction rate constant between IBP and 1O_2 . This result confirms that the hypothesis $k_{10} [IBP] \ll k_{11}$ was justified.

Reaction with irradiated AQ2S. The choice of AQ2S is motivated by the fact that this compound has a reactive triplet state but it does not yield either $\bullet\text{OH}$ or 1O_2 under irradiation, thus avoiding formation of potentially interfering transients (Loeff et al., 1983; Maurino et al., 2008, Maddigapu et al., 2010c). Figure 5 reports the initial transformation rate of IBP as a function of its initial concentration, upon UVA irradiation of 0.1 mM AQ2S at pH 2 and pH 8. From the linear trend of the plot one gets $Rate_{IBP} = (4.66 \pm 0.17) \cdot 10^{-4} [IBP]$ at pH 2 and $(3.19 \pm 0.09) \cdot 10^{-4} [IBP]$ at pH 8. AQ2S would be by far the main radiation absorber at both pH values. From the absorption spectra (Figure 1), one gets that at 330 nm the absorbance of 0.1 mM AQ2S would be 10^4 times or more higher than that of IBP at the highest adopted concentration value (10 μM). Therefore, it is possible to simply determine the photon flux absorbed by AQ2S as $P_a^{AQ2S} = \int_{\lambda} p^\circ(\lambda) [1 - 10^{-\epsilon_{AQ2S}(\lambda)b[AQ2S]}] d\lambda = 2.01 \cdot 10^{-6} \text{ einstein L}^{-1} \text{ s}^{-1}$ ($p^\circ(\lambda)$ is the spectral incident photon flux density of the UVA lamp and $b = 0.4 \text{ cm}$). The polychromatic quantum yield of IBP phototransformation by AQ2S would thus be $\Phi_{IBP,AQ2S} = Rate_{IBP} (P_a^{AQ2S})^{-1} = (2.32 \pm 0.08) \cdot 10^2 [IBP]$ at pH 2 and $(1.59 \pm 0.04) \cdot 10^2 [IBP]$ at pH 8.

The reactive triplet state $^3AQ2S^*$ accounts for the degradation processes that take place with AQ2S under irradiation. It has a formation quantum yield $\Phi_{3AQ2S^*} = 0.18$ and a deactivation rate constant $k_{3AQ2S^*} = 1.1 \cdot 10^7 \text{ s}^{-1}$ (Loeff et al., 1983). The formation rate of $^3AQ2S^*$ would be $R_{3AQ2S^*} = \Phi_{3AQ2S^*} P_a^{AQ2S}$, and its deactivation would be in competition with the reaction with IBP (rate constant $k_{3AQ2S^*,IBP}$). Therefore, the transformation rate of IBP by irradiated AQ2S could be expressed as follows:

$$Rate_{IBP} = \Phi_{3AQ2S^*} \cdot P_a^{AQ2S} \cdot \frac{k_{3AQ2S^*,IBP} \cdot [IBP]}{k_{3AQ2S^*} + k_{3AQ2S^*,IBP} \cdot [IBP]} \quad (14)$$

Under the hypothesis that $k_{3AQ2S^*,IBP} [IBP] \ll k_{3AQ2S^*}$, one gets $Rate_{IBP} = \Phi_{3AQ2S^*} P_a^{AQ2S} k_{3AQ2S^*,IBP} (k_{3AQ2S^*})^{-1} [IBP]$, which is compatible with the linear trend reported in Figure 5. It is also $\Phi_{IBP,AQ2S}$

$= Rate_{IBP} (P_a^{AQ2S})^{-1} = \Phi_{3AQ2S^*} k_{3AQ2S^*,IBP} (k_{3AQ2S^*})^{-1} [IBP]$. By comparison with the experimental data, $\Phi_{IBP,AQ2S} = (2.32 \pm 0.08) \cdot 10^2 [IBP]$ at pH 2 and $(1.59 \pm 0.04) \cdot 10^2 [IBP]$ at pH 8, one gets $k_{3AQ2S^*,IBP} = (1.42 \pm 0.05) \cdot 10^{10}$ and $(9.70 \pm 0.24) \cdot 10^9 M^{-1} s^{-1}$ at pH 2 and 8, respectively. This finding confirms that the hypothesis $k_{3AQ2S^*,IBP} [IBP] \ll k_{3AQ2S^*}$ was reasonable.

Reaction with irradiated riboflavin. Riboflavin is another well-known sensitiser. It produces 1O_2 under irradiation and its excited triplet state ($^3Ri^*$) also reacts through electron transfer with electron-donor molecules (Barbieri et al., 2008). The solutions containing riboflavin (5.4 μM) and IBP (10 μM) were buffered at pH 8 and irradiated in aerated solution for 1 h, to limit riboflavin loss to 10 %. The rate of IBP consumption was quite small: $5.5 \cdot 10^{-11} M s^{-1}$. Considering that the absorbance of riboflavin at 365 nm is 0.053, the incident photon flux is $1.2 \cdot 10^{-6}$ Einstein $L^{-1} s^{-1}$ and the quantum yield of $^3Ri^*$ formation is 0.375 in neutral water (Islam et al., 2003), the rate of $^3Ri^*$ production in our system would be $5.1 \cdot 10^{-8} M s^{-1}$. In another set of experiments, we observed that $^3Ri^*$ is efficiently quenched by oxygen with a rate constant of $1.06 \cdot 10^9 M^{-1} s^{-1}$. The pseudo first-order rate constant of $^3Ri^*$ deactivation (k_{3Ri^*}) in neutral deoxygenated aqueous solution is $1.5 \cdot 10^5 s^{-1}$ (Kouras et al., unpublished results), which raises to $4.2 \cdot 10^5 s^{-1}$ in aerated systems because of the reaction between $^3Ri^*$ and O_2 . When considering both the reaction between $^3Ri^*$ and IBP and the production of 1O_2 by $^3Ri^*$, followed by reaction of 1O_2 with IBP, it is possible to write the rate of IBP transformation as follows:

$$Rate_{IBP} = 5.1 \cdot 10^{-8} \cdot \left(\frac{k_{3Ri^*,IBP} \cdot [IBP]}{4.2 \cdot 10^5 + k_{3Ri^*,IBP} \cdot [IBP]} + \frac{2.7 \cdot 10^5}{4.2 \cdot 10^5} \frac{k_{10} \cdot [IBP]}{k_{11} + k_{10} \cdot [IBP]} \right) \quad (15)$$

The first term in the bracket corresponds to the oxidation of IBP by $^3Ri^*$ and the second to the oxidation of IBP by 1O_2 . Using $k_{10} = (6.00 \pm 0.58) \cdot 10^4 M^{-1} s^{-1}$ and $k_{11} = 2.5 \cdot 10^5 s^{-1}$, the rate of IBP consumption through 1O_2 is equal to $(7.9 \pm 0.8) \cdot 10^{-14} M s^{-1}$ and is thus negligible. This means that in our experimental conditions IBP mainly disappears by direct reaction with $^3Ri^*$. The rate constant of the reaction $k_{3Ri^*,IBP}$ is estimated to be $(4.5 \pm 0.4) \cdot 10^7 M^{-1} s^{-1}$. This value is two orders of magnitude lower than that measured in the case of AQ2S.

Modelling the phototransformation kinetics of IBP in surface waters

The availability of the direct photolysis quantum yield and of the reaction rate constants of the anionic IBP form with $\bullet\text{OH}$, $^1\text{O}_2$ and $^3\text{AQ2S}^*/^3\text{Ri}^*$ (proxies for $^3\text{CDOM}^*$) allow the calculation of the first-order rate constant of IBP transformation (k_{IBP}) as a function of water chemical composition and column depth. The model approach to link substrate reactivity and environmental features is described in detail elsewhere (Albinet et al., 2010a; Maddigapu et al., 2010a; Vione et al., 2010; Hatipoglu et al., 2010; Maddigapu et al., 2011). Figure S2-SM reports the sunlight spectrum adopted for the calculations, which corresponds to a 22 W m^{-2} irradiance in the UV (Frank and Klöpffer, 1988). A major issue for the assessment of outdoor reactivity is that sunlight irradiance is not constant. The time unit adopted in the cited model is the summer sunny day (SSD), which corresponds to a fair-weather 15 July at 45°N latitude. The incident UV energy in a SSD is equivalent to 10 hours continuous irradiation at 22 W m^{-2} UV irradiance (Maddigapu et al., 2010b). When applying the model, the first-order rate constant k_{IBP} of IBP phototransformation is given in units of SSD^{-1} , while the half-life times $\tau_{\text{IBP}} = \ln 2 (k_{\text{IBP}})^{-1}$ have units of SSD.

Inclusion in the model of the IBP kinetic data obtained here suggests that direct photolysis and reactions with $\bullet\text{OH}$ and possibly $^3\text{CDOM}^*$ would be the main IBP transformation pathways in surface waters. Under the hypothesis that $k_{^3\text{CDOM}^*,\text{IBP}} \sim k_{^3\text{AQ2S}^*,\text{IBP}} = 9.7 \cdot 10^9 \text{ M}^{-1} \text{ s}^{-1}$, with low dissolved organic carbon (DOC, expressed as NPOC, Non-Purgeable Organic Carbon) the order of importance of the three relevant pathways would be $\bullet\text{OH} > \text{photolysis} > ^3\text{CDOM}^*$. At high NPOC it would be $^3\text{CDOM}^* > \text{photolysis} > \bullet\text{OH}$. Such a scenario could be compatible with previous results of IBP photodegradation in surface water samples under irradiation, which suggest that reaction with $\bullet\text{OH}$ would not be the only relevant process (Packer et al., 2003). More recently, significant reactivity has been found between IBP and fulvic acids under irradiation (Jacobs et al., 2011). On the other hand, taking $k_{^3\text{CDOM}^*,\text{IBP}} \sim k_{^3\text{Ri}^*,\text{IBP}} = 4.5 \cdot 10^7 \text{ M}^{-1} \text{ s}^{-1}$, the reaction with $^3\text{CDOM}^*$ would be minor even at high NPOC.

Figure 6 reports the model results for k_{IBP} as a function of nitrite and NPOC, with fixed nitrate ($51 \mu\text{M}$), bicarbonate (2.1 mM) and carbonate ($26 \mu\text{M}$) and with a water column depth of 1 m. In Figure 6a it is hypothesised that IBP reacts with $^3\text{CDOM}^*$ with $k_{^3\text{CDOM}^*,\text{IBP}} = 9.7 \cdot 10^9 \text{ M}^{-1} \text{ s}^{-1}$, following the results obtained with AQ2S. In Figure 6b it is hypothesised $k_{^3\text{CDOM}^*,\text{IBP}} = 4.5 \cdot 10^7 \text{ M}^{-1} \text{ s}^{-1}$, in analogy with the riboflavin data. As far as Figure 6a is concerned, at low nitrite k_{IBP} has a minimum for 1 mg C L^{-1} NPOC. In the system described by Figure 6a nitrite would be the main $\bullet\text{OH}$ source (with the exclusion of the highest NPOC values, where CDOM would prevail as

source), DOM the main $\bullet\text{OH}$ sink, and ${}^3\text{CDOM}^*$ would obviously be produced by organic matter alone. At low NPOC, the k_{IBP} decrease with NPOC is due to $\bullet\text{OH}$ scavenging by DOM. The increase of k_{IBP} after the minimum would be accounted for by the role of ${}^3\text{CDOM}^*$ in the transformation of IBP. If the reaction between IBP and ${}^3\text{CDOM}^*$ is negligible, a continuous decrease of k_{IBP} with increasing NPOC is expected as shown in Figure 6b. In the latter case, DOM would scavenge $\bullet\text{OH}$ and its chromophoric moieties would compete with IBP for radiation absorption, thereby inhibiting the IBP direct photolysis. The data of Figure 6a foresee an IBP half-life time $\tau_{\text{IBP}} = \ln 2 (k_{\text{IBP}})^{-1}$ of less than one week, while those of Figure 6b suggest that the half-life time could vary from a few days to a couple of months. Also note that the adopted column depth of 1 m is quite favourable to photochemistry.

An assessment of the importance of the reaction between IBP and ${}^3\text{CDOM}^*$ can be obtained by application of our model to the IBP degradation kinetics reported by Packer et al. (2003) upon irradiation of Mississippi river water. Water data were 63 μM nitrate, 8.9 mg C L^{-1} NPOC, bicarbonate and carbonate not reported (but they are minor $\bullet\text{OH}$ sinks and the reaction between IBP and $\text{CO}_3^{\bullet-}$ is negligible) (Packer et al., 2003). The solutions have been placed in quartz bottles with diameter $d = 4.0$ cm, which would yield a geometrical slab-equivalent optical path length $b = 2 d / \pi = 2.5$ cm (Albinet et al., 2010b). Note however that, for such small b values where the inner-filter effect of the solution is expected to be small, the IBP phototransformation kinetics would depend very little on the path length. The adopted lamp was approximately five times more intense than sunlight. With this apparatus, Packer et al. (2003) obtained a first-order rate constant of 0.45 day^{-1} , which would become 0.09 day^{-1} under normal sunlight. With the input data reported above, our model yielded $k_{\text{IBP}} = 0.24 \text{ SSD}^{-1}$ with $k_{3\text{CDOM}^*,\text{IBP}} = 4.5 \cdot 10^7 \text{ M}^{-1} \text{ s}^{-1}$ and 0.73 SSD^{-1} with $k_{3\text{CDOM}^*,\text{IBP}} = 9.7 \cdot 10^9 \text{ M}^{-1} \text{ s}^{-1}$. Under the hypothesis that 1 SSD = 1 day of Packer et al., it is quite likely that CDOM in Mississippi river water is poorly reactive toward IBP. Moreover, our model foresees that direct photolysis would be the main transformation reaction in the system, with $\bullet\text{OH}$ only contributing to 0.02 SSD^{-1} . Note that the model adopts the sunlight spectrum reported in Figure S2-SM, which might be significantly different from that of the lamp used by Packer et al. (medium-pressure Hg-vapour lamp filtered by borosilicate glass), in particular at the wavelengths around 300 nm that are the most significant for the direct photolysis of IBP.

It is also possible to compare the IBP elimination rate constant in late summer months, derived from the field data of Tixier et al. (2003) in the epilimnion of the Swiss Lake Greifensee (5 m depth) with the model results, to get insight into the potential importance of photochemistry in the fate of IBP in surface waters. Tixier et al. (2003) obtained a field rate constant of 0.022 day^{-1} ,

which would include all possible processes such as outflow, sedimentation, $\bullet\text{OH}$ -induced photodegradation and possibly biodegradation. Note that the known processes accounted for approximately one half of the observed transformation. With the Lake Greifensee data (0.1 mM nitrate, 3.5 mg C L⁻¹ NPOC, 2 mM bicarbonate, 10 μM carbonate) (Canonica et al., 2005) and $d = 5$ m, one obtains from our model $k_{\text{IBP}} \sim 0.030 \text{ SSD}^{-1}$ for the sum of $\bullet\text{OH}$ reaction and direct photolysis, of which 0.024 SSD^{-1} would be accounted for by direct photolysis alone. Tixier et al. (2003) report that unfavourable meteorology would approximately halve the importance of photochemistry in the period under study, while our model hypothesises constant good weather. By halving k_{IBP} and its two components ($\bullet\text{OH}$ and photolysis) in our model, one gets a direct photolysis contribution of 0.012 SSD^{-1} . Under the hypothesis that 1 $\text{SSD} = 1$ day, one gets a reasonable match between model results concerning direct photolysis (0.012 SSD^{-1}) and the IBP degradation kinetics in Lake Greifensee that could not be accounted for by the known processes (0.006 – 0.011 day^{-1}). Such a comparison suggests that direct photolysis might be a significant pathway for IBP transformation in the lake epilimnion during the summer months.

Identification of IBP phototransformation intermediates

To identify the intermediates of the potentially most important photochemical transformation pathways of IBP in surface waters (direct photolysis, $\bullet\text{OH}$, $^3\text{AQ2S}^*$), a significantly higher initial IBP concentration (1 mM) was used than in the kinetic studies. It was adopted pH 8, adjusted with NaOH. Other conditions were as follows: 1 M NaNO_3 for $\bullet\text{OH}$, 1 mM AQ2S for triplet state reactivity. The adopted irradiation times were up to 6 h for $\bullet\text{OH}$, up to 3 h for $^3\text{AQ2S}^*$, and up to 3 days for the direct photolysis. Table 1 reports the IBP transformation intermediates identified by GC-MS following the different pathways. Experimental mass spectra and the comparisons with the spectra libraries are reported as SM. The direct photolysis of IBP yielded **III** and **IV** as detected phototransformation intermediates. Interestingly, the same compounds have been detected upon 254-nm irradiation of IBP (Szabó et al., 2011), which is reasonable because both UVC irradiation and our conditions (UVB) would excite the highest-wavelength absorption band of IBP. Compound **III** was also detected in the presence of $\bullet\text{OH}$, and **IV** was detected in all the three pathways under study ($\bullet\text{OH}$, direct photolysis and $^3\text{AQ2S}^*$). Considering that all the three systems were irradiated, direct photolysis could be operational at some extent also in the presence of nitrate and AQ2S. However, **III** has been identified upon IBP transformation in photo-Fenton systems (Méndez-Arriaga et al., 2010), where it probably originated by $\bullet\text{OH}$ substitution at the carbon in *alpha* to the

carboxylic group (probably *via* H abstraction followed by $\bullet\text{OH}$ addition) followed by decarboxylation/oxidation. Moreover, we detected **IV** in the system IBP + AQ2S that was irradiated under the UVA lamp, where the direct photolysis of IBP should be low to negligible. The same compound has been detected by Jacobs et al. (2011) in the presence of irradiated fulvic acids, under conditions where the direct photolysis of IBP was negligible.

Compound **I** was identified with IBP + $^3\text{AQ2S}^*$, upon transformation of the lateral chain containing the carboxylic group. Transformation of the COOH-containing (propanoic) chain was also observed for **III** and **IV** (already discussed). Compound **II**, only detected in the presence of $^3\text{AQ2S}^*$, would be produced upon shortening of both lateral chains of IBP. Interestingly, this is the only detected intermediate that underwent transformation of the isobutyl chain, which is thus expected to be much less reactive compared to the propanoic one.

The identification of **V** (only formed with $^3\text{AQ2S}^*$) was only tentative, because of the lack of the relevant mass spectrum in the adopted library. Identification was mainly based on the mass of the molecular ion that yielded the likely chemical formula $\text{C}_{13}\text{H}_{18}\text{O}$, namely an oxygen atom less than IBP. If this is the case, **V** would arise from IBP + $^3\text{AQ2S}^*$ following a reductive pathway, which might possibly involve the reduced radical species $\text{AQ2S}^{\bullet-}$ and/or AQ2S-H^{\bullet} , or superoxide/hydroperoxide. The latter may be formed via the following reactions (Maurino et al., 2008; Maddigapu et al., 2010c; Maurino et al., 2011) (ISC = Inter-System Crossing, S-H = substrate):

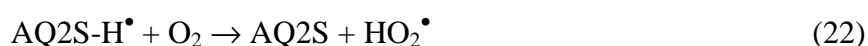
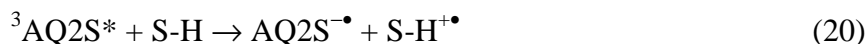

Scheme 1 summarises the transformation pathways leading to the detected IBP intermediates. The dashed arrows connecting IBP with **III** and **IV** via $^3\text{AQ2S}^*$ and $\bullet\text{OH}$ account for the theoretical possibility for them to be produced by IBP direct photolysis when nitrate and AQ2S are irradiated. Interestingly, the transformation intermediates detected in the present study do not match those identified upon IBP degradation with irradiated TiO_2 (Méndez-Arriaga et al., 2008), which suggest

that IBP in surface waters and upon TiO₂ photocatalysis would follow quite different reaction pathways.

Conclusions

- Photochemistry can be an important transformation process of IBP in surface waters. The prevailing pathways involved are the reaction with $\bullet\text{OH}$, the direct photolysis and possibly, depending on IBP reactivity, transformation induced by ${}^3\text{CDOM}^*$.
- Anionic IBP, which prevails at the pH values of surface waters has a polychromatic UVB photolysis quantum yield $\Phi_{\text{IBP}} = 0.33 \pm 0.05$, a reaction rate constant with $\bullet\text{OH}$ $k_{\text{IBP},\bullet\text{OH}} = (1.0 \pm 0.3) \cdot 10^{10} \text{ M}^{-1} \text{ s}^{-1}$, a ${}^1\text{O}_2$ rate constant $k_{\text{IBP},{}^1\text{O}_2} = (6.00 \pm 0.58) \cdot 10^4 \text{ M}^{-1} \text{ s}^{-1}$, a ${}^3\text{AQ2S}^*$ rate constant $k_{\text{IBP},{}^3\text{AQ2S}^*} = (9.70 \pm 0.24) \cdot 10^9 \text{ M}^{-1} \text{ s}^{-1}$, and a ${}^3\text{Ri}^*$ rate constant $k_{\text{IBP},{}^3\text{Ri}^*} = (4.5 \pm 0.4) \cdot 10^7 \text{ M}^{-1} \text{ s}^{-1}$. Moreover, IBP does not react with $\text{CO}_3^{\bullet-}$ to a significant extent. The results obtained with AQ2S and riboflavin as model systems for CDOM are quite contrasting, showing that the reactivity of IBP with oxidant triplets is greatly influenced by the triplet nature.
- We compared our model predictions with literature data of irradiation of Mississippi water samples and with a field study carried out in Lake Greinfensee, Switzerland. In both cases it is suggested a poor reactivity of ${}^3\text{CDOM}^*$ toward IBP and an important role of the direct photolysis.
- IBP phototransformation mainly takes place via lateral chain shortening, and the propanoic chain is much more reactive than the isobutyl one. The IBP aldehyde, which would arise upon IBP reduction, was also tentatively identified in the presence of AQ2S under irradiation.

Acknowledgements

Financial support by PNRA – Progetto Antartide is gratefully acknowledged. The work of PRM in Torino was supported by a Marie Curie International Incoming Fellowship (IIF), under the FP7-PEOPLE programme (contract n° PIIF-GA-2008-219350, project PHOTONIT). The PhD grant of EDL was funded by Progetto Lagrange - Fondazione CRT, Torino, Italy.

References

Albinet, A., Minero, C., Vione, D. (2010a) UVA irradiation induces direct phototransformation of 2,4-dinitrophenol in surface water samples. *Chemosphere* 80(7), 759-763.

- Albinet, A., Minero, C., Vione, D. (2010b) Phototransformation processes of 2,4-dinitrophenol, relevant to atmospheric water droplets. *Chemosphere* 80(7), 753-758.
- Barbieri, Y., Massad, W. A., Díaz, D. J., Sanz, J., Amat-Guerri, F., García, N. A. (2008). Photodegradation of bisphenol A and related compounds under natural-like conditions in the presence of riboflavin: Kinetics, mechanism and photoproducts. *Chemosphere*, 73(4), 564-571.
- Bossmann, S. H., Oliveros, E., Kantor, M., Niebler, S., Bonfill, A., Shahin, N., Worner, M., Braun, A. M. (2004) New insights into the mechanisms of the thermal Fenton reactions occurring using different iron(II)-complexes. *Water Science and Technology* 49(4), 75-80.
- Bouillon, R. C., Miller, W. L. (2005) Photodegradation of dimethyl sulfide (DMS) in natural waters: Laboratory assessment of the nitrate-photolysis-induced DMS oxidation. *Environmental Science and Technology* 39(24), 9471-9477.
- Budac, D. and Wan, P. (1992) Photodecarboxylation-Mechanism and synthetic utility. *Journal of Photochemistry and Photobiology A: Chemistry* 67(2), 135-166.
- Buxton, G. V., Greenstock, C. L., Helman, W. P., Ross, A. B. (1988) Critical review of rate constants for reactions of hydrated electrons, hydrogen atoms and hydroxyl radicals ($\bullet\text{OH}/\bullet\text{O}^-$) in aqueous solution. *Journal of Physical and Chemical Reference Data* 17(3), 1027-1284.
- Camacho-Munoz, M. D., Sanots, J. L., Aparicio, I., Alonso, E. (2010) Presence of pharmaceutically active compounds in Donana Park (Spain) main watersheds. *Journal of Hazardous Materials* 177(1-3), 1159-1162.
- Canonica, S., Kohn, T., Mac, M., Real, F. J., Wirz, J. and Von Gunten, U. (2005) Photosensitizer method to determine rate constants for the reaction of carbonate radical with organic compounds. *Environmental Science & Technology* 39(23), 9182-9188.
- Castiglioni, S., Bagnati, R., Fanelli, R., Pomati, F., Calamari, D., Zuccato, E. (2006) Removal of pharmaceuticals in sewage treatment plants in Italy. *Environmental Science and Technology* 40(1), 357-363.
- Chiron, S., Minero, C., Vione, D. (2007) Occurrence of 2,4-dichlorophenol and of 2,4-dichloro-6-nitrophenol in the Rhône river delta (Southern France). *Environmental Science and Technology* 41(9), 3127-3133.
- Daneshvar, A., Svanfelt, J., Kronberg, I., Weyhenmeyer, G. A. (2010) Winter accumulation of acidic pharmaceuticals in a Swedish river. *Environmental Science and Pollution Research* 17(4), 908-916.
- De Graaf, M. S., Vieno, N. M., Kujawa-Roeleveld, K., Zeeman, G., Temmink, H., Buisman, C. J. N. (2011) Fate of hormones and pharmaceuticals during combined anaerobic treatment and

- nitrogen removal by partial nitrification-anammox in vacuum collected black water. *Water Research* 45(1), 375-383.
- De Lange, H. J., Peeters, E. T. H. M., Lurling, M. (2009) Changes in ventilation and locomotion of *Gammarus pulex* (Crustacea, Amphipoda) in response to low concentrations of pharmaceuticals. *Human and Ecological Risk Assessment* 15(1), 111-120.
- Fernandez, C., Gonzales-Doncel, M., Pro, J., Carbonell, G., Tarazona, J. V. (2010) Occurrence of pharmaceutically active compounds in surface waters of the Henares-Jarama-Tajo river system (Madrid, Spain) and a potential risk characterization. *Science of the Total Environment* 408(3), 543-551.
- Frank, R., Klöpffer, W. (1988) Spectral solar photon irradiance in Central Europe and the adjacent North Sea. *Chemosphere* 17(5), 985-994.
- Hatipoglu, A., Vione, D., Yalcin, Y., Minero, C., Cinar, Z. (2010) Photo-oxidative degradation of toluene in aqueous media by hydroxyl radicals. *Journal of Photochemistry and Photobiology A: Chemistry* 215(1), 59-68.
- Haag, W. R., Hoigné, J., Gassman, E., & Braun, A. M. (1984) Singlet oxygen in surface waters - part I: Furfuryl alcohol as a trapping agent. *Chemosphere*, 13(5-6), 631-640.
- Helenkar, A., Sebok, A., Zaray, G., Molnar-Pearl, I., Vasanits-Zsigrai, A. (2010) The role of the acquisition methods in the analysis of the non-steroidal anti-inflammatory drugs in Danube River by gas chromatography – mass spectrometry. *Talanta* 82(2), 600-607.
- Hoigné, J. (1990) Formulation and calibration of environmental reaction kinetics: Oxidations by aqueous photooxidants as an example. In: Stumm, W. (ed.), *Aquatic Chemical Kinetics*, Wiley, NY, pp. 43-70.
- Islam, S. D. M., Penzkofer, A., Hegemann, P. (2003) Quantum yield of triplet formation of riboflavin in aqueous solution and of flavin mononucleotide bound to the LOV1 domain of Phot1 from *Chlamydomonas reinhardtii*. *Chemical Physics* 291(1), 97-114.
- Jacobs, L. E., Fimmen, R. L., Chin, Y.-P., Mash, H. E., Weavers, L. K., 2011. Fulvic acid mediated photolysis of ibuprofen in water. *Water Research* 45(15), 4449-4458.
- Kleywegt, S., Pileggi, V., Yang, P., Hao, C. Y., Zhao, X. M., Rocks, C., Thach, S., Cheung, P., Whitehead, B. (2011) Pharmaceuticals, hormones and bisphenol A in untreated source and finished drinking water in Ontario, Canada and treatment efficiency. *Science of the Total Environment* 409(8), 1481-1488.
- Kouras, S., Amine-Khodja, A., Richard, C.. Unpublished results.
- Kuhn, H. J., Braslavsky, S. E., Schmidt, R. (2004) Chemical actinometry. *Pure and Applied Chemistry* 76(12), 2105-2146.

- Lewandowski, J., Putschew, A., Schwesig, D., Neumann, C., Radke, M. (2011) Fate of organic micropollutants in the hyporheic zone of a eutrophic lowland stream: Results of a preliminary field study. *Science of the Total Environment* 409(10), 1824-1835.
- Lin, A. Y. C., Reinhard, M. (2005) Photodegradation of common environmental pharmaceuticals and estrogens in river water. *Environmental Toxicology and Chemistry* 24(6), 1303-1309.
- Loeff, I., Treinin, A., Linschitz, H. (1983) Photochemistry of 9,10-anthraquinone-2-sulfonate in solution. 1. Intermediates and mechanism. *Journal of Physical Chemistry* 87(14), 2536-2544.
- Loos, R., Locoro, G., Contini, S. (2010) Occurrence of polar organic contaminants in the dissolved water phase of the Danube River and its major tributaries using SPE-LC-MS² analysis. *Water Research* 44(7), 2325-2335.
- Mack, J., Bolton, J. R. (1999) Photochemistry of nitrite and nitrate in aqueous solution: A review. *Journal of Photochemistry and Photobiology A: Chemistry* 128(1-3), 1-13.
- Maddigapu, P. R., Minero, C., Maurino, V., Vione, D., Brigante, M., Mailhot, G. (2010a). Enhancement by anthraquinone-2-sulphonate of the photonitration of phenol by nitrite: Implication for the photoproduction of nitrogen dioxide by coloured dissolved organic matter in surface waters. *Chemosphere* 81(11), 1401-1406.
- Maddigapu, P. R., Vione, D., Ravizzoli, B., Minero, C., Maurino, V., Comoretto, L., Chiron, S., (2010b) Laboratory and field evidence of the photonitration of 4-chlorophenol to 2-nitro-4-chlorophenol and of the associated bicarbonate effect. *Environmental Science and Pollution Research* 17(5), 1063-1069.
- Maddigapu, P. R., Bedini, A., Minero, C., Maurino, V., Vione, D., Brigante, M., Mailhot, G., Sarakha, M. (2010c) The pH-dependent photochemistry of anthraquinone-2-sulfonate. *Photochemical and Photobiological Sciences* 9(3), 323-330.
- Maddigapu, P. R., Minella, M., Vione, D., Maurino, V., Minero, C. (2011) Modeling phototransformation reactions in surface water bodies: 2,4-Dichloro-6-nitrophenol as a case study. *Environmental Science and Technology* 45(1), 209-214.
- Martell, A. E., Smith, R. M., Motekaitis, R. J., 1997. Critically selected stability constants of metal complexes database, version 4.0.
- Matamoros, V., Duhec, A., Albaiges, J., Bayona, J. M. (2009) Photodegradation of carbamazepine, ibuprofen, ketoprofen and 17- α -ethinylestradiol in fresh and seawater. *Water, Air and Soil Pollution* 196(1-4), 161-168.
- Maurino, V., Borghesi, D., Vione, D., Minero, C. (2008) Transformation of phenolic compounds upon UVA irradiation of anthraquinone-2-sulfonate. *Photochemical and Photobiological Sciences* 7(3), 321-327.

- Maurino, V., Bedini, A., Borghesi, D., Vione, D., Minero, C. (2011). Phenol transformation photosensitized by quinoid compounds. *Physical Chemistry Chemical Physics* 10(4), 601-609.
- Méndez-Arriaga, F., Esplugas, S., Giménez, J., 2008. Photocatalytic degradation of non-steroidal anti-inflammatory drugs with TiO₂ and simulated solar irradiation. *Water Research* 42, 585-594.
- Méndez-Arriaga, F., Esplugas, S., Giménez, J., 2010. Degradation of the emerging contaminant ibuprofen in water by photo-Fenton. *Water Research* 44, 589-595.
- Miller, J. S. (2005) Rose-Bengal sensitized photooxidation of 2-chlorophenol in water using solar simulated light. *Water Research* 39(2-3), 412-422.
- Minella, M., Romeo, F., Vione, D., Maurino, V., Minero, C. (2011) Low to negligible photoactivity of lake-water matter in the size range from 0.1 to 5 µm. *Chemosphere* 83(11), 1480-1485.
- Moldovan, Z., Chira, R., Alder, A. C., 2009. Environmental exposure of pharmaceuticals and musk fragrances in the Somes River before and after upgrading the municipal wastewater treatment plant Cluj-Napoca, Romania. *Environmental Science and Pollution Research* 16 (Suppl. I), 46-54.
- Morasch, B., Bonvin, F., Reiser, H., Grandjean, D., de Alencastro, L. F., Perazzolo, C., Chevre, N., Kohn, T. (2010) Occurrence and fate of micropollutants in the Vidy Bay of Lake Geneva, Switzerland. Part II: Micropollutant removal between wastewater and raw drinking water. *Environmental Toxicology and Chemistry* 29(8), 1658-1668.
- Nissenson, P., Dabdub, D., Das, R., Maurino, V., Minero, C., Vione, D., 2010. Evidence of the water-cage effect on the photolysis of NO₃⁻ and FeOH²⁺. Implications of this effect and of H₂O₂ surface accumulation on photochemistry at the air-water interface of atmospheric droplets. *Atmospheric Environment* 44, 4859-4866.
- Oulton, R. L., Kohn, T., Cwiertny, D. M. (2010) Pharmaceuticals and personal care products in effluent matrices: A survey of transformation and removal during wastewater treatment and implications for wastewater management. *Journal of Environmental Monitoring* 12(11), 1956-1978.
- Packer, J. L., Werner, J. J., Latch, D. E., McNeill, K., Arnold, W. A. (2003) Photochemical fate of pharmaceuticals in the environment: Naproxen, diclofenac, clofibric acid, and ibuprofen. *Aquatic Sciences* 65(4), 342-351.
- Pailler, J.-Y., Krein, A., Pfister, L., Hoffmann, L., Guignard, C. (2009) Solid phase extraction coupled to liquid chromatography-tandem mass spectrometry analysis of sulfonamides, tetracyclines, analgesics and hormones in surface water and wastewater in Luxembourg. *Science of the Total Environment* 407(16), 4736-4743.

- Parij, N., Nagy, A. M., Neve, J. (1995) Linear and non linear competition plots in the deoxyribose assay for determination of rate constants for reaction of non steroidal anti-inflammatory drugs with hydroxyl radicals. *Free Radical Research* 23(6), 571-579.
- Peuravuori, J., Pihlaja, K. (2009) Phototransformation of selected pharmaceuticals under low-energy UVA-vis and powerful UVB-UVA irradiations in aqueous solutions – The role of natural dissolved organic chromophoric material. *Analytical and Bioanalytical Chemistry* 394(6), 1621-1636.
- Pomati, F., Castiglioni, S., Zuccato, E., Fanelli, R., Vigetti, D., Rossetti, C., Calamari, D. (2006). Effects of a complex mixture of therapeutic drugs at environmental levels on human embryonic cells. *Environmental Science and Technology* 40(7), 2442-2447.
- Prousek, J. (2007) Fenton chemistry in biology and medicine. *Pure and Applied Chemistry* 79(12), 2325-2338.
- Quinn, B., Gagne, F., Blaise, C. (2008) The effects of pharmaceuticals on the regeneration of the cnidarian, *Hydra attenuata*. *Science of the Total Environment* 402(1), 62-69.
- Quinn, B., Gagne, F., Blaise, C. (2009) Evaluation of the acute, chronic and teratogenic effects of a mixture of eleven pharmaceuticals on the cnidarian, *Hydra attenuata*. *Science of the Total Environment* 407(3), 1072-1079.
- Rodgers, M. A. J., Snowden, P. T. (1982) Lifetime of $^1\text{O}_2$ in liquid water as determined by time-resolved infrared luminescence measurements. *Journal of the American Chemical Society* 104(20), 5541-5543.
- Santos, J. L., Aparicio, I., Callejón, L., Alonso, E. (2009) Occurrence of pharmaceutically active compounds during 1-year period in wastewaters from four wastewater treatment plants in Seville (Spain). *Journal of Hazardous Materials* 164(2-3), 1509-1516.
- Szabó, R. K., Megyeri, Cs., Illés, L., Gajda-Schranz, K., Mazellier, P., Dombi, A., 2011. Phototransformation of ibuprofen and ketoprofen in aqueous solutions. *Chemosphere* 84, 1658-1663.
- Teijon, G., Candela, L., Tamoh, K., Molina-Diaz, A., Fernandez-Alba, A. R. (2010) Occurrence of emerging contaminants, priority substances (2008 105 CE) and heavy metals in treated wastewater and groundwater at Depurbaix facility (Barcelona, Spain). *Science of the Total Environment* 408(17), 3584-3595.
- Tiehm, A., Schmidt, N., Stieber, M., Sacher, F., Wolf, L., Hoetzel, H. (2011) Biodegradation of pharmaceutical compounds and their occurrence in the Jordan Valley. *Water Resources Management* 25(4), 1195-1203.

- Tixier, C., Singer, H. P., Oellers, S., Müller, S. R. (2003) Occurrence and fate of carbamazepine, clofibrac acid, diclofenac, ibuprofen, ketoprofen, and naproxen in surface waters. *Environmental Science and Technology* 37(6), 1061-1068.
- Valcarcel, Y., Alonso, S. G., Rodriguez-Gil, J. L., Maroto, R. R., Gil, A., Catala, M. (2011). Analysis of the presence of cardiovascular and analgesic/anti-inflammatory/antipyretic pharmaceuticals in river- and drinking-water of the Madrid Region in Spain. *Chemosphere* 82(7), 1062-1071.
- Vione, D., Khanra, S., Cucu Man, S., Maddigapu, P. R., Das, R., Arsene, C., Olariu, R. I., Maurino, V., Minero, C. (2009a) Inhibition vs. enhancement of the nitrate-induced phototransformation of organic substrates by the $\bullet\text{OH}$ scavengers bicarbonate and carbonate. *Water Research* 43(18), 4718-4728.
- Vione, D., Maurino, V., Minero, C., Carlotti, M. E., Chiron, S., Barbati, S. (2009b) Modelling the occurrence and reactivity of the carbonate radical in surface freshwater. *Comptes Rendus Chimie* 12(8), 865-871.
- Vione, D., Khanra, S., Das, R., Minero, C., Maurino, V., Brigante, M., Mailhot, G. (2010) Effect of dissolved organic compounds on the photodegradation of the herbicide MCPA in aqueous solution. *Water Research* 44(20), 6053-6062.
- Waiser, M. J., Humphries, D., Tumber, V., Holm, J. (2011) Effluent-dominated streams. Part 2: Presence and possible effects of pharmaceuticals and personal care products in wascana Creek, Saskatchewan, Canada. *Environmental Toxicology and Chemistry* 30(2), 508-519.
- Wang, C. A., Shi, H. L., Adams, C. D., Gamagedara, S., Stayton, I., Timmons, T., Ma, Y. F. (2011). Investigation of pharmaceuticals in Missouri natural and drinking water using high performance liquid chromatography – tandem mass spectrometry. *Water Research* 45(4), 1818-1828.
- Wang, L., Ying, G. G., Zhao, J. L., Yang, X. B., Chen, F., Tao, R., Liu, S., Zhou, L. J. (2010). Occurrence and risk assessment of acidic pharmaceuticals in the Yellow River, Hai River and Liao River of north China. *Science of the Total Environment* 408(16), 3139-3147.
- Wilkinson, F., Brummer, J. (1981) Rate constants for the decay and reactions of the lowest electronically excited singlet-state of molecular oxygen in solution. *Journal of Physical and Chemical Reference Data* 10(4), 809-1000.
- Yu, C. P., Chu, K. H. (2009) Occurrence of pharmaceuticals and personal care products along the West Prong Little Pigeon River in east Tennessee, USA. *Chemosphere* 75(10), 1281-1286.
- Yuan, F., Hu, C., Hu, X., Qu, J., Yang, M. (2009) Degradation of selected pharmaceuticals in aqueous solution with UV and UV/H₂O₂. *Water Research* 43(6), 1766-1774.

- Zhang, X., Oakes, K. D., Ciu, S. F., Bragg, I., Servos, M. R., Pawliszyn, J. (2010) Tissue-specific *in vivo* bioconcentration of pharmaceuticals in rainbow trout (*Oncorhynchus mykiss*) using space-resolved solid-phase microextraction. *Environmental Science and Technology* 44(9), 3417-3422.
- Zhao, J. L., Ying, G. G., Wang, L., Yang, J. F., Yang, X. B., Yang, L. H., Li, X. (2009). Determination of phenolic endocrine disrupting chemicals and acidic pharmaceuticals in surface waters of the Pearl Rivers in South China by gas chromatography-negative chemical ionization-mass spectrometry. *Science of the Total Environment* 407(2), 962-974.
- Zhao, J. L., Ying, G. G., Liu, Y. S., Chen, F., Yang, J. F., Wang, L., Yang, X. B., Stauber, J. L., Warne, M. S. (2010) Occurrence and a screening-level risk assessment of human pharmaceuticals in the Pearl River system, South China. *Environmental Toxicology and Chemistry* 29(6), 1377-1384.
- Zuccato, E., Castiglioni, S., Fanelli, R. (2005) Identification of the pharmaceuticals for human use contaminating the Italian aquatic environment. *Journal of Hazardous Materials* 122(3), 205-209.

Table 1. IBP transformation intermediates detected under the different studied conditions. Near each formula it is reported the GC retention time (t_R) and the reaction pathway that generated the relevant intermediate. DP = direct photolysis, n/a = not applicable, (*) = tentative identification. The match between the experimental mass spectra and the library ones is reported in the Supplementary Material. Identification implied an overall mass spectrometric match > 85% and the match of the most abundant ions and of the molecular one.

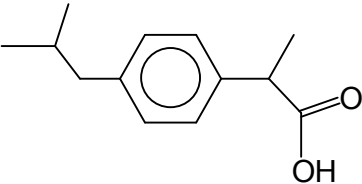
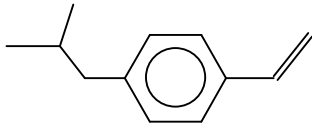
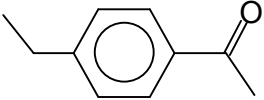
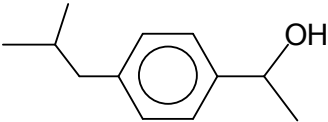
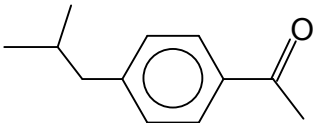
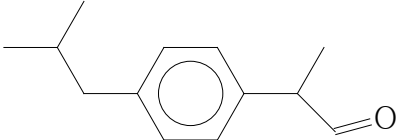
Compound	Acronym	t_R , min	Formation pathway
	IBP	15.04	n/a
	I	11.65	³ AQ2S*
	II	12.59	³ AQ2S*
	III	13.08	[•] OH, DP
	IV	13.40	[•] OH, DP, ³ AQ2S*
	V (*)	14.72	³ AQ2S*

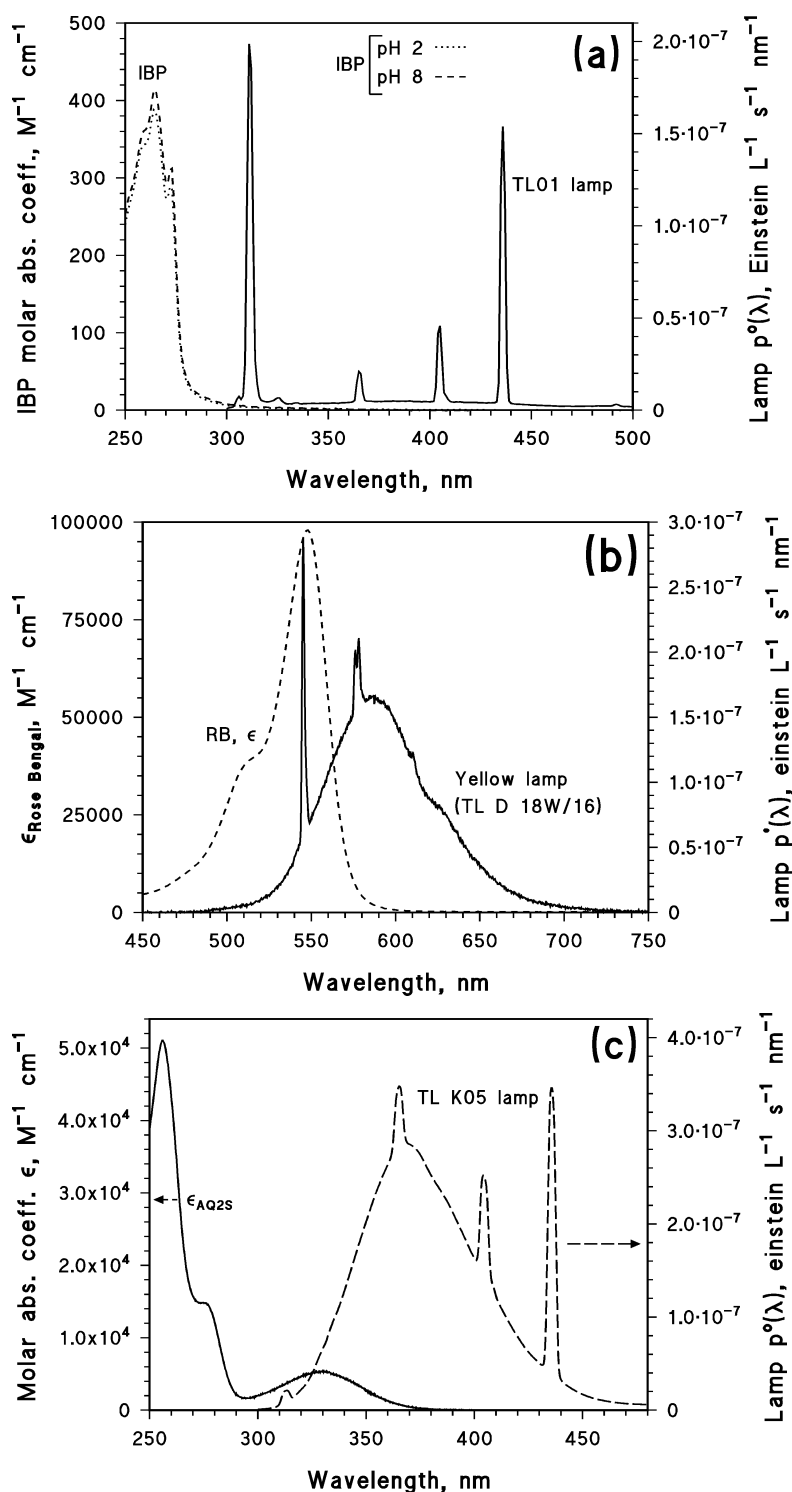

Figure 1. (a) Absorption spectrum of ibuprofen (IBP) at pH 2 and 8. Incident spectral photon flux density $p^{\circ}(\lambda)$ of the adopted TL 01 lamp (emission maximum at 313 nm).
 (b) Absorption spectrum of Rose Bengal (RB). Incident spectral photon flux density of the yellow lamp (TL D 18W/16 Yellow).
 (c) Absorption spectrum of antraquinone-2-sulphonate (AQ2S). Incident spectral photon flux density of the UVA lamp (TL K 05).

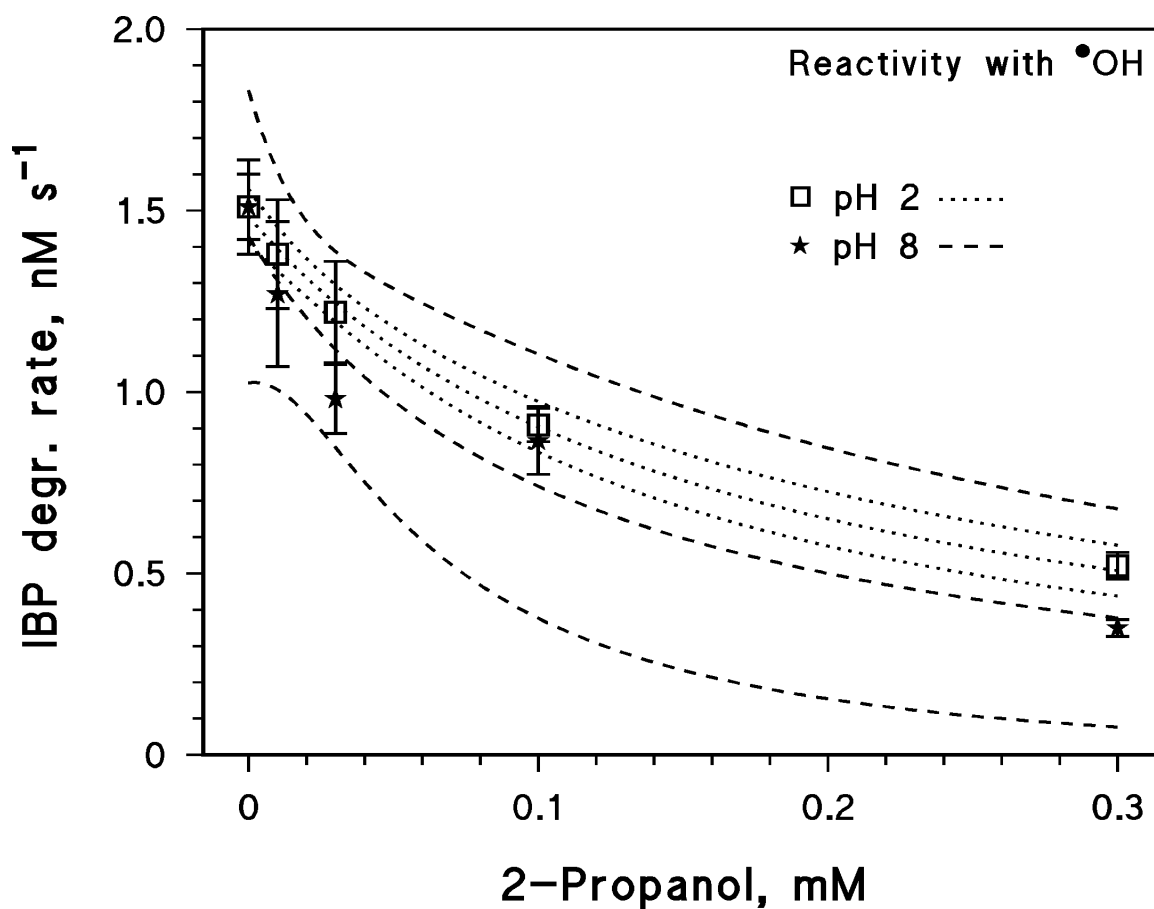

Figure 2. Initial transformation rates of 20 μM IBP upon irradiation of 10 mM NaNO_3 , as a function of the concentration of added 2-propanol, at pH 2 (open squares, dotted curves) and 8 (solid stars, dashed curves). The pH values were adjusted with HClO_4 and NaOH , respectively. Note that there are three curves for each data set. The central curve is the fit one, the lateral curves are the 95% confidence bands. $\text{nM} = 10^{-9}$ M. Irradiation was carried out under the TL 01 lamp.

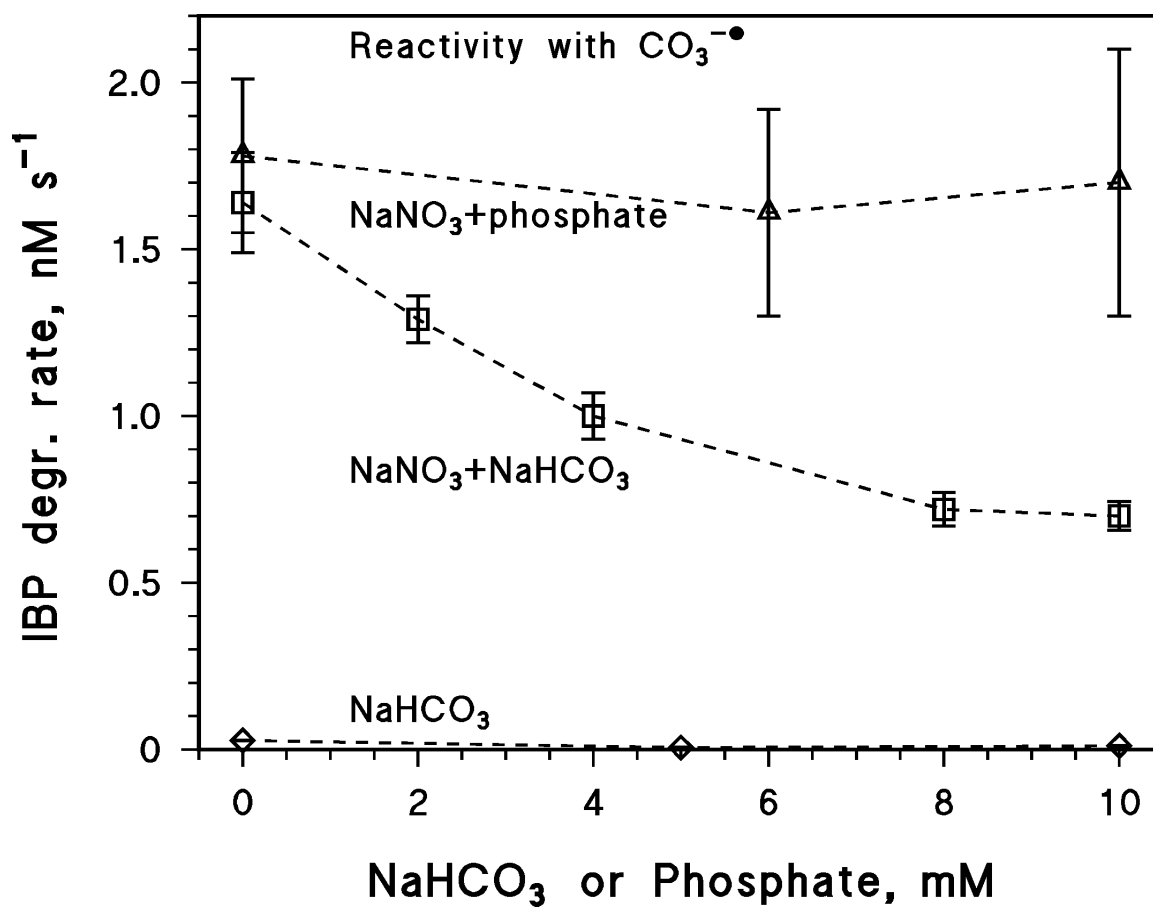

Figure 3. Initial transformation rates upon irradiation of (\square) 20 μM IBP and 10 mM NaNO_3 , as a function of the concentration of NaHCO_3 ; (Δ) 20 μM IBP and 10 mM NaNO_3 , as a function of the concentration of added phosphate buffer (same concentration as NaHCO_3 and same pH, within 0.1 units); (\diamond) 20 μM IBP without nitrate, as a function of NaHCO_3 concentration. $\text{nM} = 10^{-9}$ M. Irradiation was carried out under the TL 01 lamp.

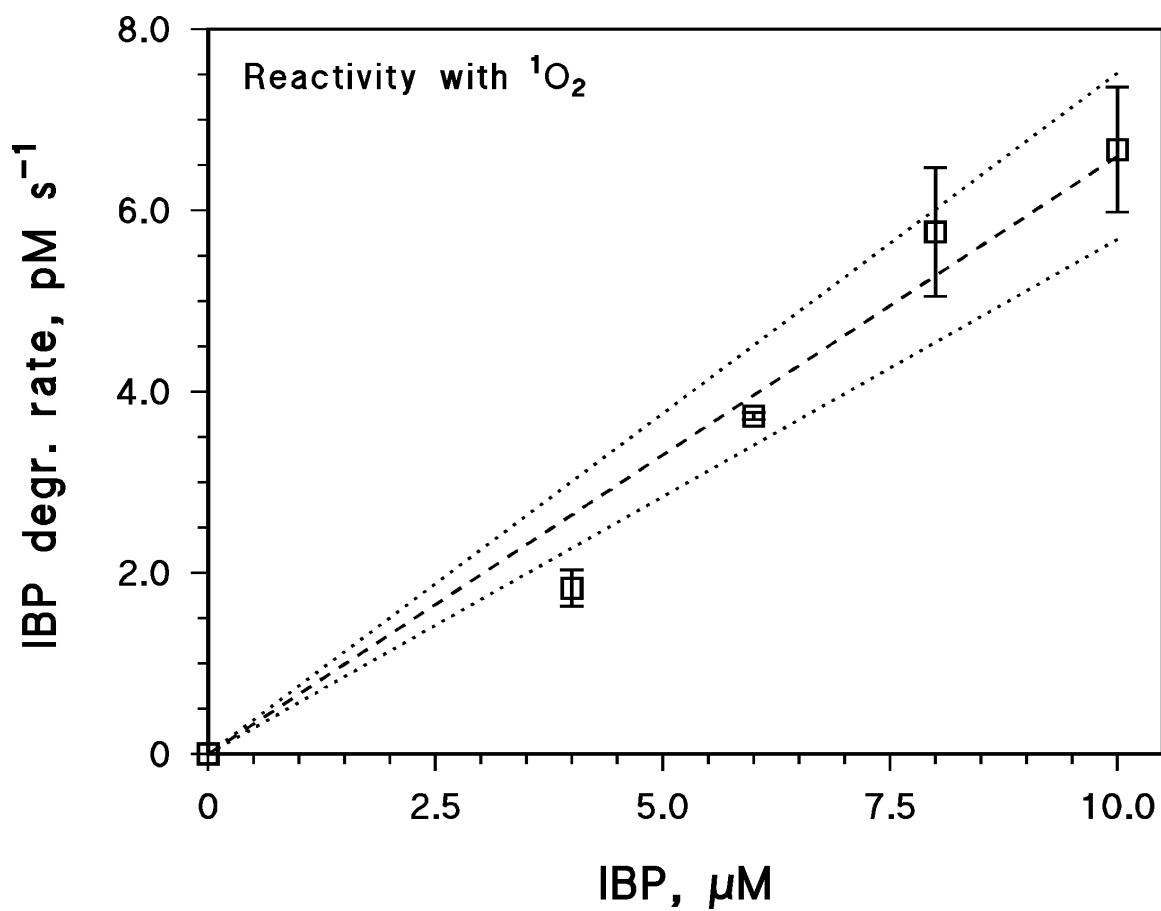

Figure 4. Initial transformation rates of IBP upon irradiation of 10 μM Rose Bengal (RB) under the yellow lamp (Philips TL D 18W/16), as a function of the IBP concentration. The solution pH was 8, adjusted with NaOH. The lamp and RB spectra are reported in Figure 1b. $\text{pM} = 10^{-12}$ M. The regression line is dashed, the 95% confidence bands are dotted.

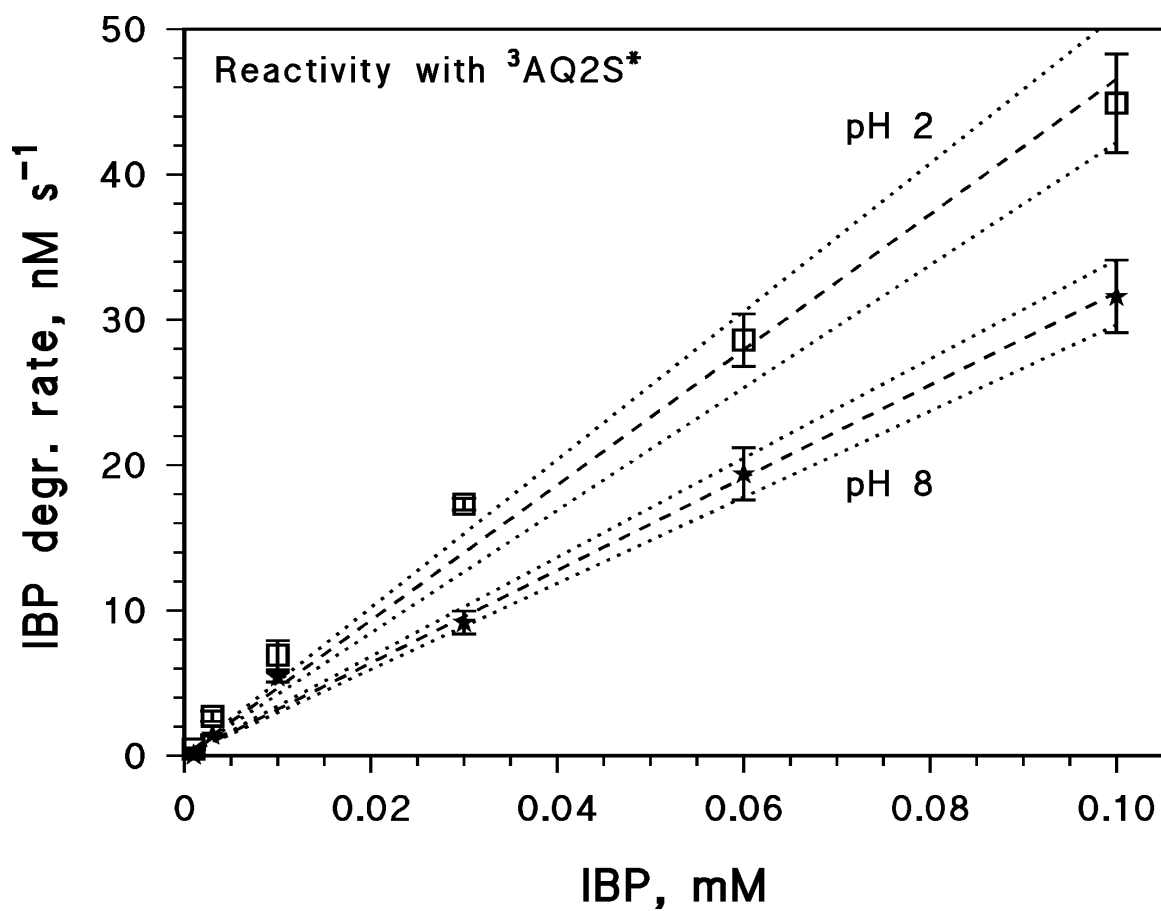

Figure 5. Initial transformation rates of IBP upon UVA irradiation of 1 mM AQ2S, as a function of the concentration of IBP at pH 2 and 8. The pH values were adjusted with HClO₄ and NaOH, respectively. The regression lines are dashed, the 95% confidence bands are dotted.

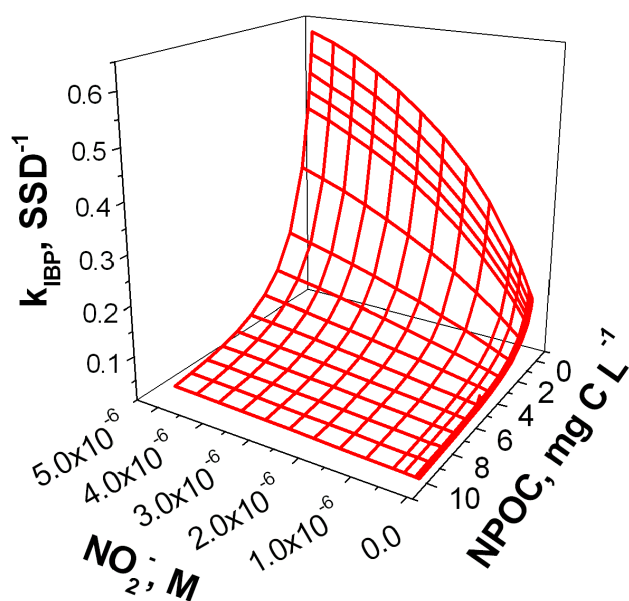
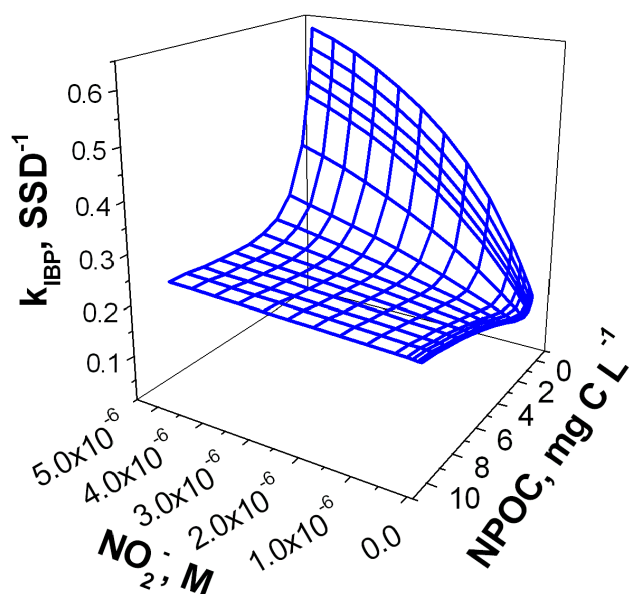
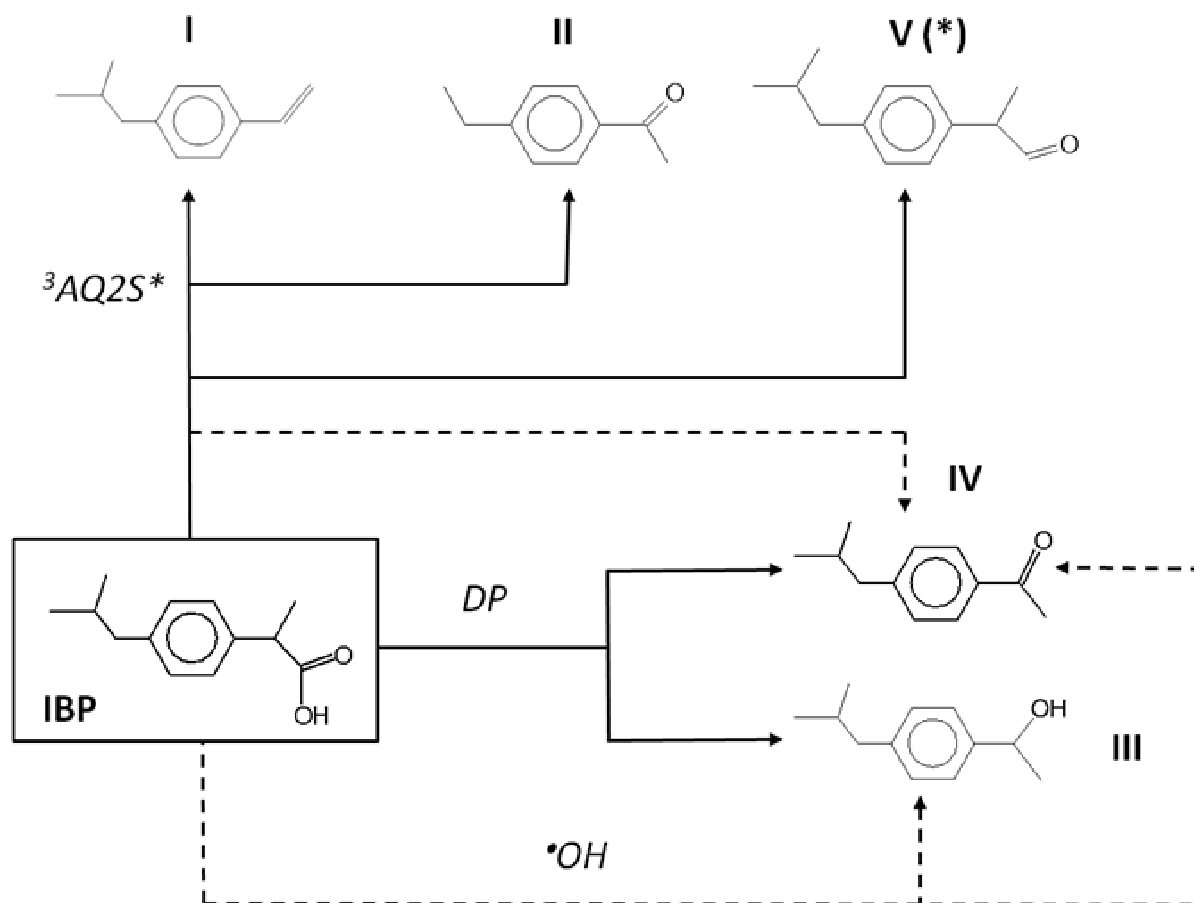

Figure 6. (a) First-order transformation rate constant of IBP, as a function of nitrite concentration and the NPOC values. Other conditions: 51 μM nitrate, 2.1 mM bicarbonate, 26 μM carbonate. Here it is hypothesised $k_{IBP,3CDOM^*} = 9.7 \cdot 10^9 \text{ M}^{-1} \text{ s}^{-1}$.
 (b) First-order transformation rate constant of IBP, under the hypothesis that $k_{IBP,3CDOM^*} = 4.5 \cdot 10^7 \text{ M}^{-1} \text{ s}^{-1}$. Other conditions are same as before.



Scheme 1. A summary of the processes leading to the detected intermediates under the studied irradiation conditions. Note that identification of **V** is only tentative, as is the assignment of **III** and **IV** as IBP transformation intermediates upon reaction with $\cdot\text{OH}$ and/or ${}^3\text{AQ2S}^*$ (see dashed arrows). DP = direct photolysis; (*) = tentative identification.