

AperTO - Archivio Istituzionale Open Access dell'Università di Torino

Performance assessment of a multi-energy system for a food industry

This is a pre print version of the following article:

Original Citation:

Availability:

This version is available <http://hdl.handle.net/2318/1546133> since 2020-06-03T18:09:25Z

Published version:

DOI:10.1016/j.egypro.2015.11.867

Terms of use:

Open Access

Anyone can freely access the full text of works made available as "Open Access". Works made available under a Creative Commons license can be used according to the terms and conditions of said license. Use of all other works requires consent of the right holder (author or publisher) if not exempted from copyright protection by the applicable law.

(Article begins on next page)



UNIVERSITÀ DEGLI STUDI DI TORINO

This is an author version of the contribution published on:

Questa è la versione dell'autore dell'opera:

Energy Procedia, volume 82, 2015, [doi:10.1016/j.egypro.2015.11.867](https://doi.org/10.1016/j.egypro.2015.11.867)

A. Biglia, E. Fabrizio, M. Ferrara, P. Gay, D. Ricauda Aimonino

volume 82, Elsevier, 2015, pag. 540-545

The definitive version is available at:

La versione definitiva è disponibile alla URL:

<http://www.sciencedirect.com/science/article/pii/S1876610215026272>

Performance assessment of a multi-energy for a food industry

Alessandro Biglia¹, Enrico Fabrizio^{1,*}, Maria Ferrara², Paolo Gay^{1,3}, Davide Ricauda Aimonio¹

¹*DI.S.A.F.A. – Università degli Studi di Torino, 2 Largo Paolo Braccini, 10095 Grugliasco (TO) – Italy*

²*DENERG – Politecnico di Torino, 24 Corso Duca degli Abruzzi, 10129 Torino – Italy*

³*CNR-IEIIT – 24 Corso Duca degli Abruzzi, 10129 Torino – Italy*

Abstract

The energy saving is becoming an important topic also in the food industry. For this reason, it is important to use multi-energy systems to produce hot water for processes and space heating. The application considered in this paper, which concerns a chocolate factory, focuses on the hot water production through a multi-source storage tank. The water inside the tank is heated by four solar panels when there is enough solar radiation and by a gas back-up boiler. The cold aqueduct water, which it is going to be heated in the accumulator, is first preheated recovering waste heat from the condenser of the chiller. The system was equipped with an energy monitoring and recording device. The thermal model was used to analyse the hot water production system during the summer season considering the options of the heat recovery and of the solar thermal exploitation. The performance analysis was developed in order to establish energy savings that may be achieved.

Keyword: *Food industry; Multi-energy systems; TRNSYS modelling; Solar thermal; Heat recovery*

1. Introduction

Industrial energy savings play an important role in process industries [1], [2] because of various factors. First of all, the rising cost of both electricity and fossil fuels involves an increase of cost of bills and consequently the percentage of energy costs are becoming not negligible in the global financial balance of the industries. Another aspect is related to the energy certificates that industries can obtain in order to gain economic benefits and for being more competitive in the market sector.

The food industry is not considered an energy intensive industry because energy costs are a small part of the total profit and loss account. However, the energy consumptions in food industry may be not negligible whenever all direct and indirect energy drivers (i.e. gas burned in the boiler or gasoline used for food transportation) are considered. Fossil fuels are the most common energy sources for thermal processes, in particular natural gas, while the electric energy is mainly used for cooling processes, refrigeration and machine drive. Around half of all energy inputs are used to process raw materials into final products [3]. The energy efficiency measures able to reduce energy consumption that may be adopted are for example:

- increase in the efficiency of energy production by installation of new energy converters (several examples are presented in [3]);
- reduction of the final energy demand by a better process scheduling, avoiding whenever possible temporal concurrence of high energy demanding tasks [4], [5];
- waste heat recovery;
- use of different energy sources, fossil and renewable ones, in multi-energy integrated systems in order to produce the energy carriers [6], [7].

In literature, several works about strategies for energy savings in food industry can be found. For example, in order to define road maps towards energy efficiency measures, Muller et al. [8] have proposed an energy management method based on both top-down and bottom-up approaches. It is very important to emphasize that one method is not preferable to the other one because only starting from the global energy consumption of the factory (e.g. analysing energy bills, top-down approach) it is possible to develop and implement thermal models for the specific process operations that require more energy (bottom-up approach). Another case study [9] shows that a detailed bottom-up approach can be used in order to study heat pump systems for recovering waste heat in the French food & drink industry. Also the potential for low-grade heat recovery in

the UK food and drink processing industry [10] was studied. Others possible solutions to recover waste heat are, for example, pinch analysis method [11] and low temperature organic Rankine cycles [12].

In this paper, a thermal model of a multi-energy system for a chocolate industry was developed within the TRNSYS[®] software tool and was used to study and optimize the global energy performance of the system during the summer season. The thermal model was calibrated against measured data obtained by a monitoring system installed in the existing plant. The scope of this paper is to analyse from the numerical point of view the effectiveness of the installed heat recovery system and sketch possible scenarios that may be adopted to increase the fraction of RES. The paper is structured as follows: Section 2 gives a description of the case study; Section 3 describes the TRNSYS model and Section 4 presents the results.

2. The case study

A chocolate industry located in Turin, in the north of Italy, is the case study presented in the paper. The building is composed by the main floor at the ground level of around 800 m², a basement and a first floor used as office space. The chocolate processing takes place in the laboratory, located at the ground floor, where cocoa beans are roasted, debacterised and finally shattered in order to obtain cocoa butter. During these operating stages, steam and hot water are used for debacterisation process and for cleaning machinery and equipment used for the processing of cocoa butter in praline.

2.1 The energy system

The plant scheme of the industry is shown in Fig. 1. Steam and hot water (DHW) used in the laboratory are produced in the boiler room.

The steam from the boiler is always available and in summer season it is used only for thermal processes in the laboratory, while in winter season it is also used to heat water for space heating. As regards the DHW production, a 1,500 l multi-source water storage tank (HW) is connected to the water supply network. The water inside the tank is heated by four flat plate solar collectors and by an auxiliary gas heater when the temperature of the water, at the top of the tank, is lower than 65 °C. The pump of the solar circuit is regulated by a differential thermostat which acquires the temperatures of the coldest point inside the tank and of the outlet of the solar panels. The efficiency of the DHW production is improved by a recovery system installed on the condenser of the chiller. Indeed, the condenser is cooled transferring thermal energy to a 200 l heat recovery water storage (HR) that pre-heats the water from the supply network. The possible excess heat is dissipated into the ambient air.

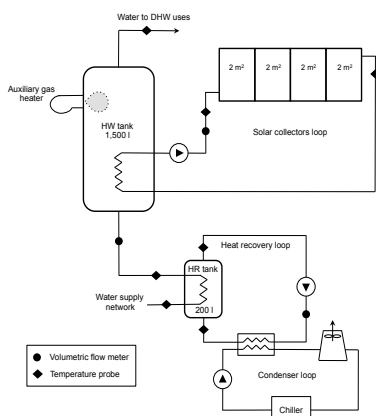

Fig. 1. Energy system scheme

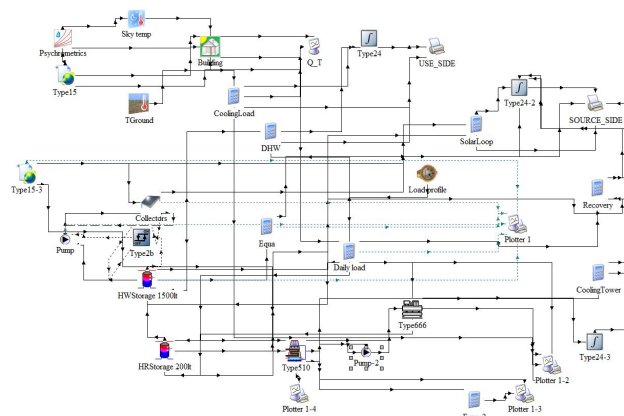

Fig. 2. The model in the TRNSYS interface

2.2 The monitoring system

The plant was equipped with an energy monitoring system. In Fig. 1 volumetric flow meters (circle) and temperature probes (diamond) are indicated. Thereby, it is possible to assess supply and return temperature levels, volumetric flow rate, thermal energy and instantaneous thermal power of the following parts of the plant:

- multi-source water storage tank (HW) + water supply network;
- solar collectors loop;
- heat recovery loop;
- heating energy to the building.

3. The system modelling

The model of the system was developed within the TRNSYS[®] simulation environment. The graphical representation of the whole model is shown in Fig. 2. The building model is located in the upper part of the diagram while the multi-source system is located in the lower part of the diagram.

3.1 Use-side modelling

Using the TRNSYS Type 56 and the TRNBuild interface, the ground floor of the building, occupied by the food laboratory, was modeled as a unique thermal zone, whose net floor area is equal to 792 m². It is adjacent to the non-conditioned basement and to the conditioned office zone located on the first floor. Part of the ceiling corresponds to the flat roof where solar panels are located. The building opaque external envelope is composed by 50 cm thick massive walls made of bricks, while the transparent envelope is made of double-glass windows (with a WWR around 30%). The cooling set point temperature in the laboratory was set to 22 °C from Monday to Friday, between 6 am and 7 pm. The laboratory zone occupancy was set to 10 working people from Monday to Friday between 8 am and 6 pm, while other internal gains due to light and appliances were set to 30 W/m². The natural ventilation rate was set to 1 vol/h during occupancy.

The typical daily load profile of the DHW use is shown in Fig. 3a. The daily hot water demand was assumed equal to 6,445 l/day.

3.2 Source-side modelling

The modelling of the subsystem that supplies space cooling and DHW production is presented in this section. Many TRNSYS types were used to model the system and in particular:

- Type 1 for the performance of multiple flat plate solar collectors that are linked in series. The area of each solar collector is 2.0 m² with $\eta_0 = 0.8$, $a_1 = 3.927 \text{ W}/(\text{m}^2\text{K})$, $a_2 = 0.0138 \text{ W}/(\text{m}^2\text{K}^2)$. The fluid of the solar loop is a mixture of water and glycol (55 %).
- Type 2b (differential temperatures controller) for regulation of the solar loop. The pump of the solar loop is running whenever the difference between the temperatures in the HW tank and at the outlet of solar collectors is greater than 10 °C, it stops if temperature difference reaches 2 °C.
- Type 60 for stratified fluid storage tanks with internal heat exchangers. This type was used to model the HW tank (Fig. 1), which is a 1,500 l puffer with a temperature set point for DHW equal to 65 °C, and for modelling the HR tank, a 200 l puffer.
- Type 666, for the water cooled chiller. The type is based on manufacturer performance data provided as external text files. The rated capacity was set to 90 kW and the rated COP to 3.28.
- Type 510 for a closed circuit cooling tower connected to the condenser loop. The water of the condenser loop goes from the condenser of the chiller to the HR tank before going into the cooling tower. In this way, part of the wasted heat can be recovered for tempering the DHW from the water supply network.

The simulation time-step was set to 5 minutes.

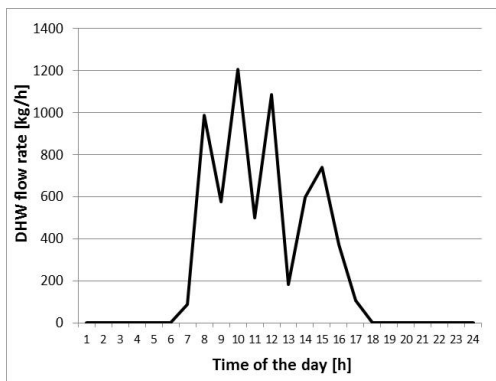

Fig. 3a. Daily load profile for DHW

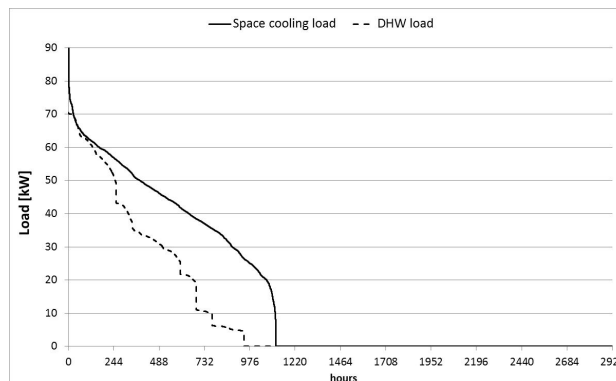

Fig. 3b. Cumulative frequency of the space cooling load (blue curve) and DHW load (red curve)

4. Results

Simulations were run for a complete summer period (1st June – 30th September, corresponding to 2,928 hours). The cumulative frequency curves of the DHW heating load and the space cooling load of the laboratory are reported in Fig. 3b. The cooling energy required for the space cooling over the whole considered period was equal to 48,645 kWh, which corresponds to 61.4 kWh/m²a. The heating energy required for the hot water production is equal to 30,812 kWh (38.9 kWh/m²).

The simulations were organized as follows. A first simulation run (System Configuration SC 0) was carried out without heat recovery from the chiller condenser in order to fix a baseline condition. Then, the simulation of the complete system was performed (SC 1).

Simulations results are reported in Table 1 in terms of solar radiation available on the collectors surface (Rsol), useful solar energy collected (Qsol), mean seasonal solar collectors efficiency (η), heat recovery from the chiller condenser (Qhr), heating energy from the gas auxiliary heater (Qgas), heat waste from the cooling tower (Qct).

In SC 0, on a seasonal basis, the seasonal efficiency of the hot water production is equal to 0.96 (and obtained not considering the efficiency of the gas heater). Results in Table 1 show that the solar system accounts for 6.9% of energy required for the hot water production.

In the case of the system of Fig. 1 (SC 1), the hot water production seasonal efficiency slightly decreases to 0.95 (again not considering the efficiency of the gas heater), and the DHW production is obtained for the 6.3% from the solar thermal, showing a slight decrease with respect to SC 0, for the 16.3% from the heat recovery, while the remaining part is provided by the auxiliary heater. In order to study the time-correspondence between the DHW load and the availability of the heat recovery, the correlation coefficient between the DHW load and the cooling load time series was computed and was equal to 0.72, which means a quite good correlation.

In order to reduce the gas energy consumption and increase the system efficiency, a sensitivity analysis on the solar collector area (SC 2) and on the heat recovery tank volume and heat exchanger (SC 3) was carried out. Some results are reported in Table 1. In the SC 2 case, the solar collectors area was assumed doubled while in the SC 3 case the volume of the heat recover tank was doubled. It can be seen that large solar collector area increases the solar fraction while it leads to a small decrease of the solar system efficiency. In the last case, a larger HR tank increases the heat recovery, even if it is hard to go beyond 20%. For all cases, it can be seen that the heat recovered fraction on the total dissipated heat is very small (from 7.6 % to 9.1%).

Table 1. Simulation results in the various system configurations (SC 0 – SC 3)

SC	Rsol [kWh]	Qsol [kWh]	η [-]	Qhr [kWh]	Qgas [kWh]	Qct [kWh]
SC 0	5,715	2,201	0.385	-	29,891	69,419
SC 1	5,715	2,043	0.357	5,296	25,073	64,039
SC 2	11,431	3,680	0.322	5,297	24,303	64,080
SC 3	5,715	2,204	0.386	6,298	23,805	63,079

5. Conclusions

A multi-energy system for a food industry was studied by transient simulations. In particular, the performance of the storage system for the heat recovery of the condenser of the factory chiller, and its integration with a solar system, was assessed. Results show that solar integration becomes profitable, from the energy point of view, only if the collector's area is increased. However, this would lead to high investment costs that is not sure to be compensated by savings due to the reduction of energy requirement.

On the other hand, the heat recovery system results to be more profitable in reducing the amount of energy required by the gas heater, even if an amount of energy is still dissipated in the cooling tower.

The real system is under monitoring so the model of the system may be calibrated against measured data allowing the future optimization of the design variables (storage volumes, storage temperatures, etc.) to maximize the overall efficiency of the system. Further development of the work should also include techno-economic analysis for optimizing the system from both points of view, checking economic feasibility.

Acknowledgements

Authors would like to thank the owner of the chocolate factory for supporting this research.

References

- [1] International Energy Agency (iea). [Online] - www.iea.org/topics/energyefficiency/subtopics/industry/
- [2] International Panel on Climate Change (IPCC). Fifth Assessment report (AR5). [Online] - www.ipcc.ch/report/ar5/
- [3] Wang L. Energy efficiency technologies for sustainable food processing. *Energ Effic* 2014;7:791-810.
- [4] Comba L, Belforte G, Gay P. Modeling techniques for the control of thermal exchanges in mixed continuous-discontinuous flow food plants. *J Food Eng* 2011;106:177-87. doi: 10.1016/j.jfoodeng.2011.04.015.
- [5] Comba L, Gay P, Piccarolo P, Ricauda Aimonio D. Thermal processes in the candy process of chestnuts. *Acta Horticulturae* 2010;866:587-94.
- [6] Fabrizio E, Filippi M, Virgone J. Trade-off between environmental and economic objectives in the optimization of multi-energy systems. *Build Simul* 2009;2:29-40.
- [7] Fabrizio E. Feasibility of polygeneration in energy supply systems for health-care facilities under the Italian climate and boundary conditions. *Energy Sustain Dev* 2011;15:92-103.
- [8] Muller DCA, Marechal FMA, Wolewinski T, Roux PJ. An energy management method for the food industry. *Appl Therm Eng* 2007;27:2677-86.
- [9] Seck GS, Guerassimoff G, Maïzi N. Heat recovery with heat pumps in non-energy intensive industry: A detailed bottom-up model analysis in the French food & drink industry. *Appl Energ* 2013;111:489-504.
- [10] Law R, Harvey A, Reay D. Opportunities for low-grade heat recovery in the UK food processing industry. *Appl Therm Eng* 2013;53:188-96.
- [11] Kemp IC. *Pinch Analysis and Process Integration – A User Guide*, second ed. Elsevier (2007).
- [12] Handayani TP, Law R, Reay DA, Harvey AP. Organic Rankine Cycle Opportunities in the Proces Industry. *Proc. SusTEM Conference 2011* (Newcastle-upon-Tyne, UK).

Biography



Enrico Fabrizio (Torino, 1978), PhD in Energy Technology at the Politecnico di Torino and at the INSA de Lyon, is assistant professor at the Department of Agricultural, Forest and Food Sciences of the University of Torino since 2008.