

AperTO - Archivio Istituzionale Open Access dell'Università di Torino

Cannabinoid receptors are widely expressed in goldfish: molecular cloning of a CB2-like receptor and evaluation of CB1 and CB2 mRNA expression profiles in different organs.

This is the author's manuscript

Original Citation:

Availability:

This version is available <http://hdl.handle.net/2318/133032> since 2016-03-16T11:03:01Z

Published version:

DOI:10.1007/s10695-013-9783-9

Terms of use:

Open Access

Anyone can freely access the full text of works made available as "Open Access". Works made available under a Creative Commons license can be used according to the terms and conditions of said license. Use of all other works requires consent of the right holder (author or publisher) if not exempted from copyright protection by the applicable law.

(Article begins on next page)

Published in final edited form as:

Fish Physiol Biochem. 2013 October ; 39(5): 1287–1296. doi:10.1007/s10695-013-9783-9.

Cannabinoid receptors are widely expressed in goldfish: molecular cloning of a CB2-like receptor and evaluation of CB1 and CB2 mRNA expression profiles in different organs

Erika Cottone^{a,*}, Valentina Pomatto^{a,*}, Fulvio Cerri^a, Ezio Campantico^a, Ken Mackie^b, Massimiliano Delpero^a, Alda Guastalla^a, Claudio Dati^a, Patrizia Bovolin^a, and Maria Fosca Franzoni^{a,†}

^aDepartment of Life Science and Systems Biology, University of Turin, 10123 Torino, Italy

^bDepartment of Psychological and Brain Sciences, Gill Center for Biomolecular Science, Indiana University, Bloomington, Indiana, USA

Abstract

Cannabinoids, the bioactive constituents of *Cannabis sativa*, and endocannabinoids, among which the most important are anandamide and 2-arachidonoylglycerol, control various biological processes by binding to specific G protein-coupled receptors, namely CB1 and CB2 cannabinoid receptors. While a vast amount of information on the mammalian endocannabinoid system does exist, few data have been reported on bony fish. In the goldfish, *Carassius auratus*, the CB1 receptor has been cloned and its distribution has been analyzed in the retina, brain and gonads, while CB2 had not yet been isolated. In the present paper we cloned the goldfish CB2 receptor and show that it presents a quite high degree of amino acid identity with zebrafish *Danio rerio* CB2A and CB2B receptors, while the percentage of identity is lower with the pufferfish *Fugu rubripes* CB2, as also confirmed by the phylogenetic analysis. The sequence identity becomes much lower when comparing the goldfish and the mammalian CB2 sequences; as for other species, goldfish CB2 and CB1 amino acid sequences share moderate levels of identity. Western-blotting analysis shows the CB2 receptor as two major bands of about 53 kDa and 40 kDa, and other faint bands with apparent molecular masses around 70 kDa, 57 kDa and 55 kDa. Since the distribution of a receptor could give information on its physiological role, we evaluated and compared CB1 and CB2 mRNA expression in different goldfish organs by means of quantitative Real-Time PCR. Our results show that both CB1 and CB2 receptors are widely expressed in the goldfish, displaying some tissue specificities, thus opening the way for further functional studies on bony fish and other non-mammalian vertebrates.

Keywords

endocannabinoid system; *Carassius auratus*; sequence identity; Western-blotting; qReal-Time PCR

Corresponding author: Dr. Erika Cottone, Department of Life Science and Systems Biology, University of Turin, via Accademia Albertina 13, 10123 Torino, Italy; erika.cottone@unito.it; phone number: 0039 011 6704678; fax number: 0039 011 2364678.

*These authors contributed equally to the work

†This paper is dedicated to the memory of Maria Fosca Franzoni who sadly passed away on 26th July 2012; concluding the writing of the paper she had scientifically supervised is for us the best way to remember her and her everlasting attachment to academic and scientific projects

Introduction

The endocannabinoid system comprises several components, among which are specific seven transmembrane-domain receptors, namely CB1 and CB2 cannabinoid receptors, and their exogenous (e.g. Δ^9 -tetrahydrocannabinol) and endogenous ligands (e.g. anandamide and 2-arachidonoylglycerol). CB1 are the most abundant G protein-coupled receptors (GPCR) in mammalian CNS and they mediate the majority of cannabinoid central actions (Herkenham et al. 1990; Piomelli 2003), although recently CB1 were also found in peripheral organs (for a review, see Mackie 2008). CB2 were originally characterized in the mammalian immune system (Munro et al. 1993), and more recently were described in the gonads (Grimaldi et al. 2009) and in the CNS (Van Sickle et al. 2005; Ashton et al. 2006; Beltramo et al. 2006; Gong et al. 2006; Onaivi et al. 2006). The original idea that the CB1 receptor exerts physiological functions almost exclusively in the brain and CB2 in the immune system, has thus evolved into the concept that in mammals both cannabinoid receptors are involved in the control of central and peripheral functions, such as neural development, neurotransmission and inflammation, cardiovascular, respiratory and reproductive functions, hormone release and action, bone formation and energy metabolism (for a review, see Di Marzo 2009).

CB1 and CB2 cannabinoid receptors have been described in almost all the vertebrate classes and also in urochordates and cephalochordates, but not in the non-chordate invertebrate phyla, thus suggesting that they are unique to the phylum of Chordata (for a review, see Elphick 2012). CB1 and CB2 are paralogs originated by an evolutionarily ancient duplication of a common ancestral gene. Interestingly, in teleosts duplicate copies of CB1 or CB2 gene are present, possibly as a consequence of a whole genome duplication that occurred in an ancestor of teleost fish, followed by the specific loss of a duplicate gene. Thus, in *Fugu rubripes* two CB1 receptor genes were identified (Yamaguchi et al. 1996), while only one CB2 gene was found (Elphick 2002). In zebrafish, on the other hand, only one CB1 gene has been detected (Lam et al. 2006), while two CB2 genes (CB2A and CB2B) are present (Rodriguez-Martin et al. 2007). In goldfish, a CB1 sequence has been cloned (Valenti et al. 2005; Cottone et al. 2005) and the distribution of the receptor has been analyzed in the retina (Yazulla et al. 2000), CNS (Valenti et al. 2005; Cottone et al. 2005) and gonads (Cottone et al. 2008). On the other hand, CB2 had not yet been identified in goldfish.

In the present paper we cloned and characterized the *Carassius auratus* CB2 receptor; moreover, we analyzed and compared CB1 and CB2 mRNA expression profiles in different goldfish organs.

Materials and methods

Animals

Commercially supplied *Carassius auratus* adult specimens (n=12) of both sexes were deeply anesthetized with tricaine methanesulfonate (1:1000, MS222, Sandoz Ltd, Cham, Switzerland) under the guidelines established by the Italian law and the European Communities Council Directive (86/609/EEC) for animal welfare. The brain, gut, gonads, heart, liver, kidney, spleen, muscle, retina, gills were rapidly dissected out, immediately frozen in liquid nitrogen and stored at -80°C until use.

Cloning and sequence analysis of goldfish CB2 partial coding sequence

Total RNA was extracted from the spleen of two animals, using the TRIzol reagent (Invitrogen, Rockville, USA) and following manufacturer's instructions. DNA contaminants were eliminated using TURBO DNA-free kit (Applied Biosystems, Foster City, USA).

cDNA was synthesized from total RNA by using Multiscribe RT (Applied Biosystems) and random nonamers. *Carassius auratus* CB2 cDNA was amplified using primers specific for *Danio rerio* CB2A/B nucleotide sequences (available at GenBank database). The 5' sense primer, corresponding to zebrafish CB2 bases 437–456 (considering position 1 as the first nucleotide of the coding sequence), was as follows: 5'-TTT GCA TCT ACC AGG CTT CC-3'; the 3' antisense primer, corresponding to zebrafish CB2 bases 797–816, had the following sequence: 5'-CAG GAT TAG AAG GAT CAA AC-3'. PCR was performed for 40 cycles, at 45 °C annealing temperature, using Hot Start AmpliTaq Gold360 polymerase (Applied Biosystems). The 380 bp amplification product was cloned into pGEM-T-easy vector, using pGEM-T-easy Vector System (Promega, Madison, USA). *Escherichia coli* JM109 high efficiency competent cells (Promega) were transformed and recombinant colonies were identified by blue/white color screening and restriction digestion; 6 selected recombinant clones (pGEM-T-easy-CB2*Car*) were sequenced. The nucleotide sequence of the cloned *Carassius auratus* CB2 340 bp fragment is available at GenBank (accession number: GU012004). CB2 partial amino acid sequence (113 aa) was then deduced. The nucleotide and the amino acid sequence of goldfish CB2 were aligned with other known CB2 sequences, using LALIGN and ClustalW multiple alignment computer programs. Moreover, the goldfish CB2 fragment was aligned with the goldfish CB1 partial coding sequence already cloned by us (Cottone et al. 2005; Valenti et al. 2005).

Phylogenetic analysis

The goldfish CB2 partial amino acid sequence and the CB2 sequences of other vertebrates were aligned using ClustalW multiple alignment program and a phylogenetic tree was constructed using the Neighbour-Joining method (Saitou and Nei 1987).

Western-blotting analysis

Total proteins were extracted from goldfish spleen by using a boiling buffer containing 2.5% sodium dodecyl sulfate and 125 mM Tris-HCl, pH 6.8. The protein concentration was determined by means of the bicinchoninic acid technique (Pierce, Rockford, USA); 100 µg of total proteins were loaded on a 10% polyacrylamide gel, separated by sodium dodecyl sulfate–polyacrylamide gel electrophoresis and then blotted onto a polyvinylidene difluoride membrane (Amersham Biosciences, Little Chalfont, UK). Western-blotting was performed by using as a primary antibody an affinity-purified polyclonal antiserum raised against the N-terminus of the rat CB2 (first 30 amino acids: MAGCRELELTNGSNGGLEFNPKEYMILSD), diluted 1:600 in Tris-buffered saline (TBS), 5% bovine serum albumin (BSA). As a control, the anti-CB2 antibody was pre-adsorbed for 24 h at 4 °C with the corresponding immunizing fusion protein (10 µg/ml). After the incubation with an anti-rabbit IgG horseradish peroxidase-linked antiserum, the reaction was revealed with the ECL Plus Western blotting detection reagent (Amersham Biosciences) and Kodak BioMax MR Film (Kodak, Rochester, USA). The GelDoc gel documentation system and the software Quantity One (Bio-Rad Laboratories, Hercules, USA) were used to determine the molecular weight of the specific CB2 bands on the basis of the migration of the Page Ruler Plus Prestained Protein Ladder (Fermentas, Glen Burnie, USA).

qReal-Time PCR

Total RNA was isolated, as described above, from 11 different organs (brain, gut, ovary, testis, heart, liver, kidney, spleen, muscle, retina, gills) of 6 goldfish. cDNA was synthesized and amplified using the SybrGreen chemistry and Applied Biosystem 7500 thermal cycler. In particular, 2 ng (for CB1 and -actin) and 40 ng (for CB2) of cDNA were used for the amplification; three replicates of each reaction were performed. The primers specific for goldfish CB1, CB2 and -actin (used as housekeeping gene) were designed by using

Primer3 software, on the basis of the sequences available at GenBank database (accession numbers: AY674057, GU012004 and AB039726, respectively) and were as follows: CB1 5' sense primer: 5'-GCA GCG TCA TCT TCG TCT AC-3'; CB1 3' antisense primer: 5'-CGC CTC CTA ACT TGA ACA GA-3'; CB2 5' sense primer: 5'-AAA GCA AAT CGC CAT GAA ACA G-3'; CB2 3' antisense primer: 5'-CAT TCG TGC CTG TCC TTT CA-3'; -actin 5' sense primer: 5'-GAC CAA CCC AAA CCT CTC AA-3'; -actin 3' antisense primer: 5'-AGT CAA TGC GCC AAA CAG A-3'. PCR was performed at an annealing temperature of 58 °C for CB1 and CB2 and 60 °C for -actin, for 38 cycles. The amplification efficiency was determined amplifying known dilutions of a sample, according to the equation $E=10^{[-1/\text{slope}]}$ (Bustin 2000), and was maximum ($E=2$) for all the three genes. Quantitative Real-Time PCR was performed by Microarray Service, CRIBI, University of Padua, Italy.

Relative gene expression was determined using the 2^{-Ct} method, as reported previously (Livak and Schmittgen 2001), using the -actin Ct value to normalize CB1 or CB2 Ct values. Brain and spleen were used as reference organs for CB1 and CB2, respectively. In order to compare CB1 and CB2 in the same organ, CB2 Ct values were corrected to compensate for the different starting amount of amplified cDNA (theoretical difference of 4.3 cycles).

Statistical analysis

The 2^{-Ct} values obtained for CB1 or CB2 for all the organs were analysed with a GLM (General Linear Model) for repeated measures, followed by Sidak post-hoc test. Differences in CB1 and CB2 expression in the same organ were analysed with t-test; differences were considered statistically significant when $p < 0.05$.

Results

Molecular cloning and characterization of goldfish CB2 receptor

The goldfish CB2 central region was amplified from spleen homogenates by means of RT-PCR, using primers specific for zebrafish CB2A/B nucleotide sequences, at very permissive amplification conditions. In all the 6 recombinant colonies analyzed, the cloned sequence was identical; the 340 bp goldfish CB2 partial coding sequence and the deduced 113 amino acid sequence were submitted to GenBank (accession number: GU012004). Fig. 1 shows the alignment of the deduced CB2 amino acid sequence of goldfish and the other known CB2 sequences from vertebrates. As shown in Table 1a, the goldfish CB2 partial coding sequence presents a quite high degree of amino acid identity with zebrafish CB2A and CB2B (80.5% and 81.4%, respectively), while the percentage of identity is only 57.5% with the pufferfish *Fugu rubripes* CB2 and it becomes much lower when compared with mammalian CB2 sequences (about 38%). By aligning goldfish CB2 and CB1 amino acid sequences an identity of only 40.7% was found. The percentage of identity among the different sequences was generally higher when comparing the nucleotide sequences instead of the amino acid sequences (Table 1b). Based on the alignment of CB2 amino acid sequences from various species, the phylogenetic relationships of CB2 receptors were estimated and a phylogenetic tree was constructed using the Neighbour-Joining method (Fig. 2).

In order to better characterize goldfish CB2 receptor and to confirm CB2 expression at the protein level, spleen samples, already characterized to express CB2 mRNA (see above), were used to perform Western-blotting experiments (Fig. 3). By using as a primary antibody an affinity-purified polyclonal antiserum raised against the N-terminus of the rat CB2, two major bands of about 53 and 40 kDa were observed. In addition, other weak bands with apparent molecular weights around 70 kDa, 57 kDa and 55 kDa were faintly visible. When

the anti-CB2 antibody pre-adsorbed with the corresponding immunizing fusion protein was used, no bands were observed.

CB1 and CB2 mRNA expression profiles in different goldfish organs

The expression of both CB1 and CB2 mRNAs was determined by quantitative Real-Time PCR in the following organs of single animals (n=6): brain, gut, ovary, testis, heart, liver, kidney, spleen, muscle, retina, gills.

As shown in Fig. 4a, following post-hoc tests the 2^{-Ct} values for CB1 mRNA show several statistically significant variations among different organs. Abundant CB1 transcripts were found in brain, gills and liver, while they were much lower in retina, muscle and ovary. In the ovary, CB1 expression was in fact about 52-fold lower than in the brain ($p < 0.01$), used as reference organ, about 24-fold lower than in the gut ($p < 0.01$) and 82-fold lower than in the gills ($p < 0.01$). CB1 mRNA expression in the retina was about 10-fold lower than in the brain ($p < 0.01$) and 16-fold lower than in the gills ($p < 0.01$). In the spleen, CB1 mRNA levels were about 3-fold lower than in the gills ($p < 0.05$).

Concerning CB2 expression (Fig. 4b), the highest values were found in gills, liver and kidney, the lowest in ovary, muscle and retina; some statistically significant variations in CB2 mRNA expression among different organs were found. In particular, in the ovary CB2 expression was about 21-fold lower than in the gut ($p < 0.01$). CB2 mRNA expression in the retina was about 7-fold lower than in the gut ($p < 0.05$) and 30-fold lower than in the gills ($p < 0.05$).

In order to compare CB1 and CB2 transcript levels in the same goldfish organ, the expression of CB2 mRNA was referred to that of CB1 in the brain, considering the different starting amount of cDNA used for each of the two receptors. As shown in Fig. 4c, in all the investigated organs CB2 mRNA levels are much lower than CB1 levels, in particular in the brain (about 14-fold lower, $p < 0.01$), as well as in the gut and in the gills (in both cases about 4-fold lower, $p < 0.05$); also, in liver, heart and spleen CB2 expression is markedly lower than CB1 expression, although differences did not result statistically significant.

Discussion

In order to better characterize the endocannabinoid system in the goldfish, in the present paper the CB2 cannabinoid receptor was cloned from lysates of spleen, that in mammals is known to be rich in CB2 protein and is normally used as a positive control when studying CB2 expression (Ashton et al. 2006; Matias et al. 2002; Van Sickle et al. 2005; Gong et al. 2006). The goldfish CB2 partial coding sequence presents the highest degree of amino acid identity with zebrafish CB2A and CB2B receptors (over 80%), while the percentage of identity is lower with the pufferfish *Fugu rubripes* (57.5%) and quite low with mammalian CB2 sequences (about 38%). Although these data are only indicative, since only a part of the goldfish CB2 receptor has been cloned, they resulted very similar to the percentages of identity found between CB2 sequences of zebrafish and those of other vertebrates. In fact *Danio rerio* CB2A/B shows an identity of about 56% with the one of *Fugu rubripes*, 39% with human, 38% with mouse and 35% with rat (Rodriguez-Martin et al. 2007). The higher sequence identity between the goldfish and the zebrafish CB2 sequences, compared to *Fugu rubripes*, is confirmed by the lower phylogenetic distance between the CB2 receptors of the first two species and is in agreement with the fact that goldfish and zebrafish are phylogenetically closer, since both are members of the *Cyprinidae* family, while *Fugu rubripes* belongs to *Tetraodontida*. By aligning goldfish CB2 and CB1 partial amino acid sequences, an identity of only 40.7% was found. This result is in agreement with data found in mammals, where for example an identity of about 44% was found between human CB1

and CB2, thus pointing to a very early separation of the two encoding genes during phylogeny. The fact that the sequence we cloned is much more similar to the *Danio rerio* CB2A/B sequence compared to the *Carassius auratus* CB1 sequence, strongly reduce the possibility of having isolated a fragment or an isoform of goldfish CB1 and confirms the actual cloning of part of the CB2 receptor. Comparing the zebrafish CB2A and CB2B regions corresponding to the cloned goldfish CB2 sequence, as much as 7 different nucleotides can be found. This observation, together with the fact that no differences in the nucleotide sequence were found among the 6 goldfish clones analyzed, suggests that only one CB2 gene exists in *Carassius auratus*, consistently with what found in *Fugu rubripes* and *Tetraodon nigroviridis* (Elphick and Egertová 2001, 2009). The existence of two CB2 genes in zebrafish and of just one CB2 gene in other bony fish may actually reflect the specific loss of a duplicate gene after a whole genome duplication that occurred in an ancestor of teleost fish (Elphick and Egertová 2009). However, we cannot definitively exclude the existence in goldfish of a CB2 paralog gene having a sequence divergent enough that the primers used in the present work were not able to recognize it. The fact that the whole genome sequence of goldfish is still unknown, precludes in this species the use of the genome sequence analysis techniques usefully employed to search CB2 genes in other fish (Elphick 2002; Rodriguez-Martin et al. 2007).

In order to better characterize the goldfish CB2 receptor and to confirm CB2 expression at the protein level, Western-blotting experiments were performed on spleen lysates, already demonstrated to contain CB2 mRNA. Two major bands of 53 kDa and 40 kDa and very weak bands with apparent molecular weights of about 70 kDa, 57 kDa and 55 kDa were detected. Since the complete coding sequence of goldfish CB2 is still unknown, it is not yet possible to calculate the CB2 receptor molecular weight on the basis of its amino acid sequence. However, the predicted size of the CB2 protein is about 43 kDa in *Danio rerio* and 42 kDa in *Fugu rubripes*, while it is about 39 kDa in human, rat and mouse. The 40 kDa band observed in goldfish could therefore correspond to the post-translationally unmodified CB2 receptor, while the other bands could possibly be differently glycosylated forms. Alternatively, the two major bands of 53 kDa and 40 kDa could represent two alternative splicing forms of the goldfish CB2 gene. Since an antibody against fish CB2 is not available, in the present experiments we used an anti-CB2 antibody raised against the N-terminus of rat CB2. The nucleotide sequence corresponding to the goldfish CB2 N-terminus has not been cloned, therefore it is not possible to anticipate its degree of interaction with the antibody used in this study. However, it is known from other studies that the primary amino acid sequence of the CB2 N-terminus in mammals and in *Danio rerio* and *Fugu rubripes* differ significantly. Therefore the possibility of a cross-reaction with goldfish proteins other than CB2 cannot be excluded. The gold standard to demonstrate the antiserum specificity in goldfish tissues would be to use CB2 knockout goldfish, but unfortunately these do not exist. We can however consider our immunoblotting results as a first step toward the full characterization of the CB2 protein in goldfish for at least two considerations. First, we tested the epitope specificity by performing antibody preabsorption studies, finding no bands. Second, our results on the CB2 protein in goldfish are consistent with those obtained in mammals and, to the best of our knowledge, similar experiments have not yet been done in other bony fish. Western-blotting analysis on human immature dendritic cells show the presence of three immunoreactive bands of about 59 kDa, 45 kDa and 39 kDa (Matias et al. 2002). In rat, bands of about 59 kDa, 47 kDa and 39 kDa were observed in spleen lysates (Matias et al. 2002) and bands of 60 kDa, 55 kDa, and 44 kDa were found in brain lysates (Van Sickle et al. 2005). In mouse brain and spleen, a major band of approximately 53 kDa was revealed, together with other bands around 75 kDa and 37 kDa (Gong et al. 2006).

Since the localisation of a receptor could give important information on its physiological role, we analysed the expression of both CB1 and CB2 cannabinoid receptor mRNAs in different organs of the goldfish, namely brain, gut, ovary, testis, heart, liver, kidney, spleen, muscle, retina and gills. Abundant CB1 transcripts were found in brain, gills and liver, while they were much lower in retina, muscle and ovary. In some organs (i.e. muscle, spleen, kidney) CB1 mRNA levels presented considerable variations among samples, possibly because of animal variability and the limited number of goldfish specimen analysed. CB1 receptor expression has been widely investigated in the CNS of vertebrates, both in adults and during embryogenesis; on the other hand, only a few studies on its presence in peripheral districts are known. In goldfish, CB1 receptors have been reported in retina (Yazulla et al. 2000), brain (Cottone et al. 2005; Valenti et al. 2005) and gonads (Cottone et al. 2008). In zebrafish, CB1 distribution was analysed in the CNS (Lam et al. 2006), while in *Fugu rubripes* CB1 receptors have been described to be highly expressed in the brain, and to a much lesser extent in the spleen, ovary and testis (Yamaguchi et al. 1996). In mammals, CB1 receptors, although more abundant in the CNS, were also described in the pituitary (Gonzales et al. 1999; Wenger et al. 1999; Pagotto et al. 2001; Cesa et al. 2002), retina (Straiker et al. 1999; Yazulla et al. 1999, 2000; Porcella et al. 2000; Yazulla and Studholme 2001) and in peripheral organs, such as the reproductive system (Gérard et al. 1991), immune system (Kaminski et al. 1992; Bouaboula et al. 1993; Galiègue et al. 1995), gastrointestinal apparatus, heart, muscle (Gebremedhin et al. 1999), urinary bladder, adrenal glands, lung (Rice et al. 1997). However no study was conducted to quantify and compare CB1 levels in the different organs.

Concerning CB2 expression, in the goldfish we found high mRNA levels in gills, liver and kidney, while low values were detected, as for CB1 receptor, in the ovary, muscle and retina. Among bony fish, CB2 distribution has been evaluated by *in situ* hybridization and non-quantitative RT-PCR in some organs of the zebrafish (Rodriguez-Martin et al. 2007). The authors noticed a somewhat different expression of CB2A and CB2B mRNA in the various organs, but in general CB2 was found to be expressed in spleen, brain (where however ISH failed to reveal any specific labelling), pituitary, intestine, retina, gill, heart; a very weak band corresponding to CB2 was observed in muscle. Our results concerning CB2 expression in goldfish are in agreement, at least in part, with the data obtained in mammals by using RT-PCR, Northern-blotting and immunohistochemical techniques. High CB2 levels were in fact demonstrated in mammals in spleen and tonsils, both enriched in B lymphocytes, and, in lower quantities, in heart, lung, thymus and brain. However, in contrast with the present results in goldfish, the mammalian CB2 receptors seem to be absent in the liver, kidney and muscle (Galiègue et al. 1995; Van Sickle et al. 2005; Ashton et al. 2006; Beltramo et al. 2006; Gong et al. 2006; Onaivi et al. 2006).

When CB1 and CB2 mRNA levels were compared in the same goldfish organ, CB2 levels were always lower than CB1 levels. The difference was particularly strong in the brain, in line with the fact that CB1 receptors do exert a pivotal role in modulating central functions, such as locomotion, learning, memory, nociception, while CB2 receptors could have more restricted functions.

In conclusion, the present study deepens the understanding of the endocannabinoid system in goldfish and represents, to the best of our knowledge, the first approach to quantify and compare CB1 and CB2 cannabinoid receptor expression in the different organs of a non-mammalian vertebrate. Since much can be learned about the physiological role of the receptors by determining their distribution, our results could encourage further studies shedding light on the functional roles of the endocannabinoid system in bony fish and other non-mammalian vertebrates.

Acknowledgments

The authors wish to thank Dr. Marco Del Giudice and Dr. Sergio Castellano for their suggestions about the statistical analysis. This research was financially supported by the Italian Ministry of University Research and Technology (PRIN 2005, PRIN 2008 and ex-60% 2008 to MFF).

References

- Ashton JC, Friberg D, Darlington CD, Smith PF. Expression of the Cannabinoid CB2 Receptor in the Rat Cerebellum: an Immunohistochemical Study. *Neurosci Lett*. 2006; 396:113–116. [PubMed: 16356641]
- Beltramo M, Bernardini N, Bertorelli R, Campanella M, Nicolussi E, Fredduzzi S, Reggiani A. CB2 receptor-mediated antihyperalgesia: possible direct involvement of neural mechanisms. *Eur J Neurosci*. 2006; 23:530–1538.
- Bouaboula M, Rinaldi M, Carayon P, et al. Cannabinoid-receptor expression in human leukocytes. *Eur J Biochem*. 1993; 214(1):73–180.
- Bustin SA. Absolute quantification of mRNA using real-time reverse transcription polymerase chain reaction assays. *J Mol Endocrinol*. 2000; 25(2):169–193. [PubMed: 11013345]
- Cesa R, Guastalla A, Cottone E, Mackie K, Beltramo M, Franzoni MF. Relationships between CB1 cannabinoid receptors and pituitary endocrine cells in *Xenopus laevis*: an immunohistochemical study. *Gen Comp Endocrinol*. 2002; 125(1):17–24. [PubMed: 11825030]
- Cottone E, Campantico E, Guastalla A, Aramu S, Polzonetti-Magni AM, Franzoni MF. Are the cannabinoids involved in bony fish reproduction? *Ann NY Acad Sci*. 2005; 1040:273–276. [PubMed: 15891041]
- Cottone E, Guastalla A, Mackie K, Franzoni MF. Endocannabinoids affect the reproductive functions in teleosts and amphibians. *Mol Cell Endocrinol*. 2008; 286 Suppl 1(1–2):S41–S45. [PubMed: 18343023]
- Di Marzo V. The endocannabinoid system: its general strategy of action, tools for its pharmacological manipulation and potential therapeutic exploitation. *Pharmacol Res*. 2009; 60(2):77–84. [PubMed: 19559360]
- Elphick MR, Egertová M. The neurobiology and evolution of cannabinoid signaling. *Phil Trans R Soc Lond B*. 2001; 356:381–408. [PubMed: 11316486]
- Elphick MR. Evolution of cannabinoid receptors in vertebrates: Identification of a CB2 gene in the puffer fish *Fugu rubripes*. *Biol Bull*. 2002; 202:104–107. [PubMed: 11971807]
- Elphick, MR.; Egertová, M. Cannabinoid receptor genetic and evolution. In: Reggio, PH., editor. *The cannabinoid receptors*. New York, NU, USA: Humana Press; 2009. p. 123-149.
- Elphick MR. The evolution and comparative neurobiology of endocannabinoid signalling. *Phil Trans R Soc B*. 2012; 367(1607):3201–3215. [PubMed: 23108540]
- Galiègue S, Mary S, Marchand J, Dussosoy D, Carrière D, Carayon P, Bouaboula M, Shire D, Le Fur G, Casellas P. Expression of central and peripheral cannabinoid receptors in human immune tissues and leukocyte subpopulations. *Eur J Biochem*. 1995; 232:54–61. [PubMed: 7556170]
- Gebremedhin D, Lange AR, Campbell WB, Hillard CJ, Harder DR. Cannabinoid CB1 receptor of cat cerebral arterial muscle functions to inhibit L-type Ca²⁺ channel current. *Am J Physiol*. 1999; 276(6 Pt 2):H2085–H2093. [PubMed: 10362691]
- Gerard CM, Mollereau C, Vassart G, Parmentier M. Molecular cloning of a human cannabinoid receptor which is also expressed in testis. *Biochem J*. 1991; 279(Pt 1):129–134. [PubMed: 1718258]
- Gong JP, Onaivi ES, Ishiguro H, Liu QR, Tagliaferro PA, Brusco A, Uhl GR. Cannabinoid CB2 receptors: Immunohistochemical localization in rat brain. *Brain res*. 2006; 1071:10–23. [PubMed: 16472786]
- Gonzalez S, Manzanares J, Berrendero F, et al. Identification of endocannabinoids and cannabinoid CB(1) receptor mRNA in the pituitary gland. *Neuroendocrinology*. 1999; 70(2):137–145. [PubMed: 10461028]

- Grimaldi P, Orlando O, Di Siena S, Lolicato F, Petrosino S, Bisogno T, Geremia R, De Petrocellis L, Di Marzo V. The endocannabinoid system and pivotal role of the CB2 receptor in mouse spermatogenesis. *Proc Natl Acad Sci USA*. 2009; 106:11131–11136. [PubMed: 19541620]
- Herkenham M, Lynn AB, Little MD, Johnson MR, Melvin LS, De Costa BR, Rice KC. Cannabinoid receptor localization in brain. *Proc Natl Acad Sci USA*. 1990; 87:1932–1936. [PubMed: 2308954]
- Kaminski NE, Abood ME, Kessler FK, Martin BR, Schatz AR. Identification of a functionally relevant cannabinoid receptor on mouse spleen cells that is involved in cannabinoid-mediated immune modulation. *Mol Pharmacol*. 1992; 42(5):736–742. [PubMed: 1279376]
- Lam CS, Rastegar S, Strähle U. Distribution of cannabinoid receptor 1 in the CNS of zebrafish. *Neuroscience*. 2006; 138:83–95. [PubMed: 16368195]
- Livak KJ, Schmittgen TD. Analysis of relative gene expression data using real-time quantitative PCR and the 2(-Delta Delta C(T)) Method. *Methods*. 2001; 25(4):402–408. [PubMed: 11846609]
- Mackie K. Cannabinoid receptors: where they are and what they do. *J Neuroendocrinol*. 2008; 20(Suppl 1):10–14. [PubMed: 18426493]
- Matias I, Pochard P, Orlando P, Salzet M, Pestel J, Di Marzo V. Presence and regulation of the endocannabinoid system in human dendritic cells. *Eur J Biochem*. 2002; 269(15):3771–3778. [PubMed: 12153574]
- Munro S, Thomas KL, Abu-Shaar M. Molecular characterization of a peripheral receptor for cannabinoids. *Nature*. 1993; 365:61–65. [PubMed: 7689702]
- Onaivi ES, Ishiguro H, Gong JP, et al. Discovery of the presence and functional expression of cannabinoid CB2 receptors in brain. *Ann NY Acad Sci*. 2006; 1074:514–536. [PubMed: 17105950]
- Pagotto U, Marsicano G, Fezza F, et al. Normal human pituitary gland and pituitary adenomas express cannabinoid receptor type 1 and synthesize endogenous cannabinoids: first evidence for a direct role of cannabinoids on hormone modulation at the human pituitary level. *J Clin Endocrinol Metab*. 2001; 86(6):2687–2696. [PubMed: 11397872]
- Piomelli D. The molecular logic of endocannabinoid signalling. *Nat Rev Neurosci*. 2003; 4(11):873–884. [PubMed: 14595399]
- Porcella A, Maxia C, Gessa GL, Pani L. The human eye expresses high levels of CB1 cannabinoid receptor mRNA and protein. *Eur J Neurosci*. 2000; 12(3):1123–1127. [PubMed: 10762343]
- Rice W, Shannon JM, Burton F, Fiedelvey D. Expression of a brain-type cannabinoid receptor (CB1) in alveolar Type II cells in the lung: regulation by hydrocortisone. *Eur J Pharmacol*. 1997; 327(2–3):227–232. [PubMed: 9200564]
- Rodriguez-Martin I, Herrero-Turrión MJ, Marrón Fdez de Velasco E, Gonzalez-Sarmiento R, Rodríguez RE. Characterization of two duplicate zebrafish CB2-like cannabinoid receptors. *Gene*. 2007; 389:36–44. [PubMed: 17126498]
- Saitou N, Nei M. The neighbour-joining method: a new method for reconstructing phylogenetic trees. *Mol Biol Evol*. 1987; 4:406–425. [PubMed: 3447015]
- Straiker A, Stella N, Piomelli D, Mackie K, Karten HJ, Maguire G. Cannabinoid CB1 receptors and ligands in vertebrate retina: localization and function of an endogenous signaling system. *Proc Natl Acad Sci USA*. 1999; 96(25):14565–14570. [PubMed: 10588745]
- Valenti M, Cottone E, Martínez R, De Pedro N, Rubio M, Viveros MP, Franzoni MF, Delgado MJ, Di Marzo V. The endocannabinoid system in the brain of *Carassius auratus* and its possible role in the control of food intake. *J Neurochem*. 2005; 95:662–672. [PubMed: 16135090]
- Van Sickle MD, Duncan M, Kingsley PJ, et al. Identification and Functional Characterization of Brainstem Cannabinoid CB₂ Receptors. *Science*. 2005; 310:329–332. [PubMed: 16224028]
- Wenger T, Fernandez-Ruiz JJ, Ramos JA. Immunocytochemical demonstration of CB1 cannabinoid receptors in the anterior lobe of the pituitary gland. *J Neuroendocrinol*. 1999; 11(11):873–878. [PubMed: 10520138]
- Yamaguchi F, Macrae AD, Brenner S. Molecular cloning of two cannabinoid type 1-like receptor genes from the puffer fish *Fugu rubripes*. *Genomics*. 1996; 35(3):603–605. [PubMed: 8812500]
- Yazulla S, Studholme KM, McIntosh HH, Deutsch DG. Immunocytochemical localization of cannabinoid CB1 receptor and fatty acid amide hydrolase in rat retina. *J Comp Neurol*. 1999; 415(1):80–90. [PubMed: 10540359]

- Yazulla S, Studholme KM, McIntosh HH, Fan SF. Cannabinoid receptors on goldfish retinal bipolar cells: electron-microscope immunocytochemistry and whole-cell recordings. *Vis Neurosci*. 2000; 17(3):391–401. [PubMed: 10910107]
- Yazulla S, Studholme KM. Neurochemical anatomy of the zebrafish retina as determined by immunocytochemistry. *J Neurocytol*. 2001; 30(7):551–592. [PubMed: 12118162]

	I	
<i>Carassius auratus</i>	-----	
<i>Danio rerio</i> CB2A	MENKLEODQEATTWLYSNLSTQNIISTDKSLCYGLQCYMVLTTQEQKAISSICFLAGPV 60	
<i>Danio rerio</i> CB2B	MENKLEODQEATTWLYSNLSTQNIISTDKSLCYGLQCYMVLTTQEQKAISSICFLAGPV 60	
<i>Fugu rubripes</i>	-----MYKVFLCRVSAKMCSTFDRNRCKNLGCFMVIIEAEKKAIGTICLLAGPIT 50	
rat	-----MAGCRELELTNGSNGGLEFNPMEYMIISDAQQIAVAVLCTLMGLLS 47	
mouse	-----MEGCRETEVTNGSNGGLEFNPMEYMIISGQOIAVAVLCTLMGLLS 47	
human	-----MEECWVTEIANGSKDGLDNPMDYMIISLGGPOKTAVAVLCTLMGLLS 47	
	II	
<i>Carassius auratus</i>	-----	
<i>Danio rerio</i> CB2A	FLANILVLLTIASSTALRRRPSYLFISSLALADMFASCFFTTISFLDFHLLSQRDDANLYL 120	
<i>Danio rerio</i> CB2B	FLANILVLLTIASSTALRRRPSYLFISSLALADMFASCFFTTISFLDFHLLSQRDDANLYL 120	
<i>Fugu rubripes</i>	LMENAVLGVIASTATLRKRPSYLFIGSLALADVFASCFFTTISFLDFHLFRRSDATAYL 110	
rat	ALENVAVLYIILSSQRLRRKPSYLFIGSLAGADFLASVIFACNEVIFHFVHGVDGRNIFL 107	
mouse	ALENVAVLYIILSSRRVRRKPSYLFISSLAGADFLASVIFACNEVIFHFVHGVDGNAIFL 107	
human	ALENVAVLYIILSSHQRLRRKPSYLFIGSLAGADFLASVVFACSFVNFHFVHGVDGKAVFL 107	
	III	IV
<i>Carassius auratus</i>	-----	NYKVLTHAKAKLAIVLLWCVTIIISFL 28
<i>Danio rerio</i> CB2A	FKLGGVTMAFTGSSVGSLLLTALDRYLCIYQASNYKLLTRTRAKLAILLWCVTIIISFL 180	
<i>Danio rerio</i> CB2B	FKLGGVTMAFTGSSVGSLLLTALDRYLCIYQASNYKLLTRTRAKLAILLWCVTIIISFL 180	
<i>Fugu rubripes</i>	FKLGGVTMAFSSVGSLLLTALDRYLCIYQASNYKLLTRRRALLSLLILWLITFISFL 170	
rat	LKIGSVTMTFTASVGSLLLTAVDRYLCIYQASNYKLLTRGRALVALGVMWVLSALISYL 167	
mouse	LKIGSVTMTFTASVGSLLTAVDRYLCIYQASNYKLLTRGRALVALGVMWVLSALISYL 167	
human	LKIGSVTMTFTASVGSLLLTALDRYLCIYQASNYKLLTRGRALVALGVMWVLSALISYL 167	
	V	
<i>Carassius auratus</i>	PLMGWRCTTKFDPFCSHLPYVDRHYLALVTGLQFVWVFLIIVAVYVLIWKAHRHETAMG 88	
<i>Danio rerio</i> CB2A	PLMGWRCTKWLDRPCSRLFPYVDRHYLALVTGLQVLMFLIMVAVYVLIWKAHRHEANMG 240	
<i>Danio rerio</i> CB2B	PLMGWRCTKWLDRPCSRLFPYVDRHYLALVTGLQVLMFLIIVAVYVLIWKAHRHEANMG 240	
<i>Fugu rubripes</i>	PLMGWRCTPDLNPAACSELPYINPDYLACWTSFILVLLALILGAYALILWKAHRHEASMT 230	
rat	PLMGWTCCP---SPCSELPFLIPNDVLLGWLLFAILFSGIITYTYGVVLMKAHQHVASLT 224	
mouse	PLMGWTCCP---SPCSELPFLIPNDVLLGWLLFAILFSGIITYTYGVVLMKAHRHVATLA 224	
human	PLMGWTCCP---RPCSELPFLIPNDVLLSWLLFAILFSGIITYTYGHVLMKAHQHVASLS 224	
	VI	VII
<i>Carassius auratus</i>	GPKLGRPTVKGOARMRIDIQARTF-----	113
<i>Danio rerio</i> CB2A	GPKLGRSOSVKGQARMRMDIOLAHTFSLIILLILAICWLPVLSFMVVDVVRTLTNKOORMFA 300	
<i>Danio rerio</i> CB2B	GPKLGRSOSVKGQARMRMDIOLAHTFSLIILLILAICWLPVLSFMVVDVVRTLTNKOORMFA 300	
<i>Fugu rubripes</i>	SFOG--SVRTGHARMRMDIRLARTFGLIILLVGCWLPALSFMVLDVFRQLTPAQRKAKFA 288	
rat	EHQD--RQVPGIARMRLDVRLAKTLGLVMAVLLICWFPALALMGHSLVTTLSDDQVKEAFA 282	
mouse	EHQD--RQVPGIARMRLDVRLAKTLGLVMAVLLICWFPALALMGHSLVTTLSDDQVKEAFA 282	
human	GHQD--RQVPGMARMRLDVRLAKTLGLVMAVLLICWFPVLAALMAHSLATTLSDQVKAFA 282	
	VIII	
<i>Carassius auratus</i>	FCSTLCLVNSCVNPLLYALRCRELRGEMALIECCACKREHALGHTHGQITDSSSGKSK 360	
<i>Danio rerio</i> CB2A	FCSTLCLVNSCVNPLLYALRCRELRGEMALIECCACKREHALGHTHGQITDSSSGKSK 360	
<i>Danio rerio</i> CB2B	FCSTLCLVNSAVNPLLYALRCRELRLALLQLLAKLCTGRCRFPSSADLSPGPFSTEENT 348	
<i>Fugu rubripes</i>	FCSMLCLVNSMNPPIIYALRSGEIRSAHQHCLIGVKYIQLGSEGKEEAPKSSVTETA 342	
rat	FCSMLCLVNSMNPPIIYALRSGEIRSAHQHCLIGVKYIQLGSEGKEEAPKSSVTETA 342	
mouse	FCSMLCLVNSMNPPIIYALRSGEIRSAHQHCLIGVKYIQLGSEGKEEAPKSSVTETA 342	
human	FCSMLCLVNSMNPPIIYALRSGEIRSAHQHCLAHVKKVRGLGSEAKEEAPKSSVTETA 342	
	IX	
<i>Carassius auratus</i>	NPAVSGSNPEIVSGSADRQNSI-----	383
<i>Danio rerio</i> CB2A	NPAVSGSNPEIVSRSADRQNSI-----	383
<i>Danio rerio</i> CB2B	NPYLKDEVPGTRSIRLNSVSEIVNQQMNI-----	379
<i>Fugu rubripes</i>	ETLVLKDKQELGGDCLLRTSSIHSPMLSLADSANRQDVRPHCPPELTVWCVRRPISLPN 402	
rat	DVKTT-----	347
mouse	DVKTT-----	347
human	DGKITPWPDSRDLDSLDC-----	360
	X	
<i>Carassius auratus</i>	-----	
<i>Danio rerio</i> CB2A	-----	
<i>Danio rerio</i> CB2B	-----	
<i>Fugu rubripes</i>	-----	
rat	KAGQSTLL 410	
mouse	-----	
human	-----	

Fig. 1. Amino acid sequence alignment of the cloned central part of the goldfish CB2 receptor (113 aa) with the known CB2 sequences of other vertebrates. Asterisks (*) indicate positions where the amino acids are identical in all the sequences aligned, while colons (:), and periods (.) indicate the conservation among the different species of amino acids with strongly similar or weakly similar properties, respectively. Putative transmembrane domains (I–VII) are identified by grey boxes.

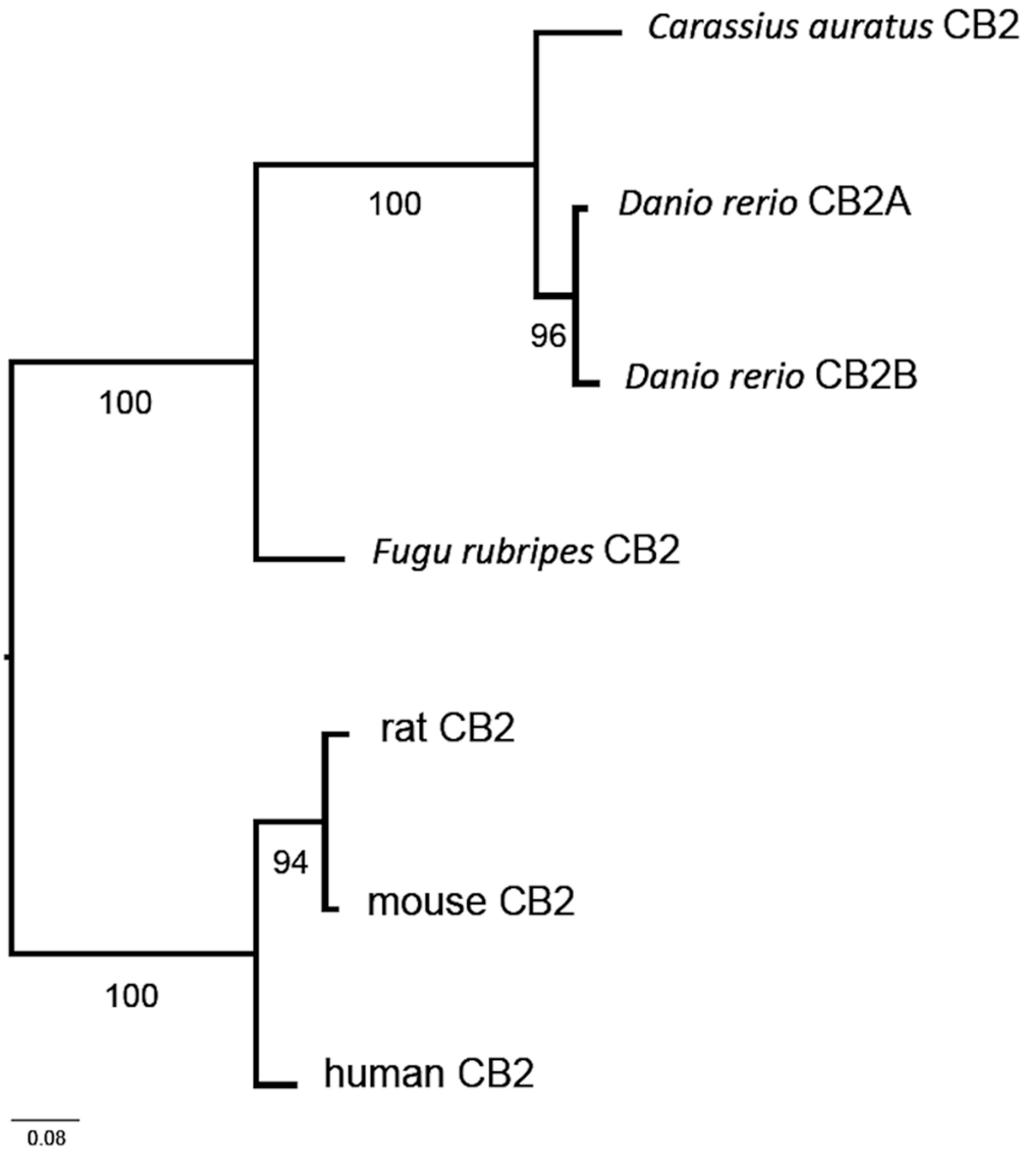

Fig. 2. Phylogenetic analysis of vertebrate CB2 cannabinoid receptors. The phylogenetic tree was constructed using the Neighbour-Joining method. Branch lengths are proportional to the estimated evolutionary distances among the receptors.

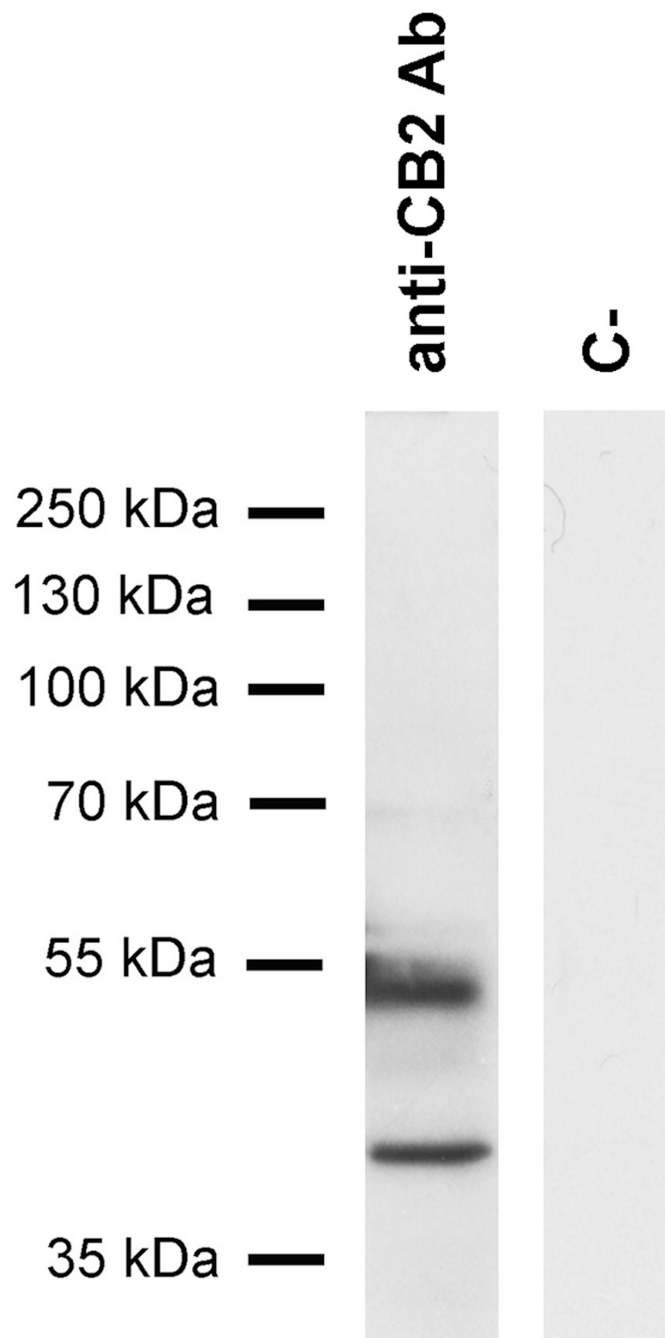

Fig. 3. Western-blotting analysis of goldfish spleen lysates. By using an anti-CB2 antibody, two major bands of about 53 kDa and 40 kDa are observed, together with other faint bands with apparent molecular weights around 70 kDa, 57 kDa and 55 kDa. The preadsorption of the antibody with the corresponding immunizing fusion protein (C-) gives no bands.

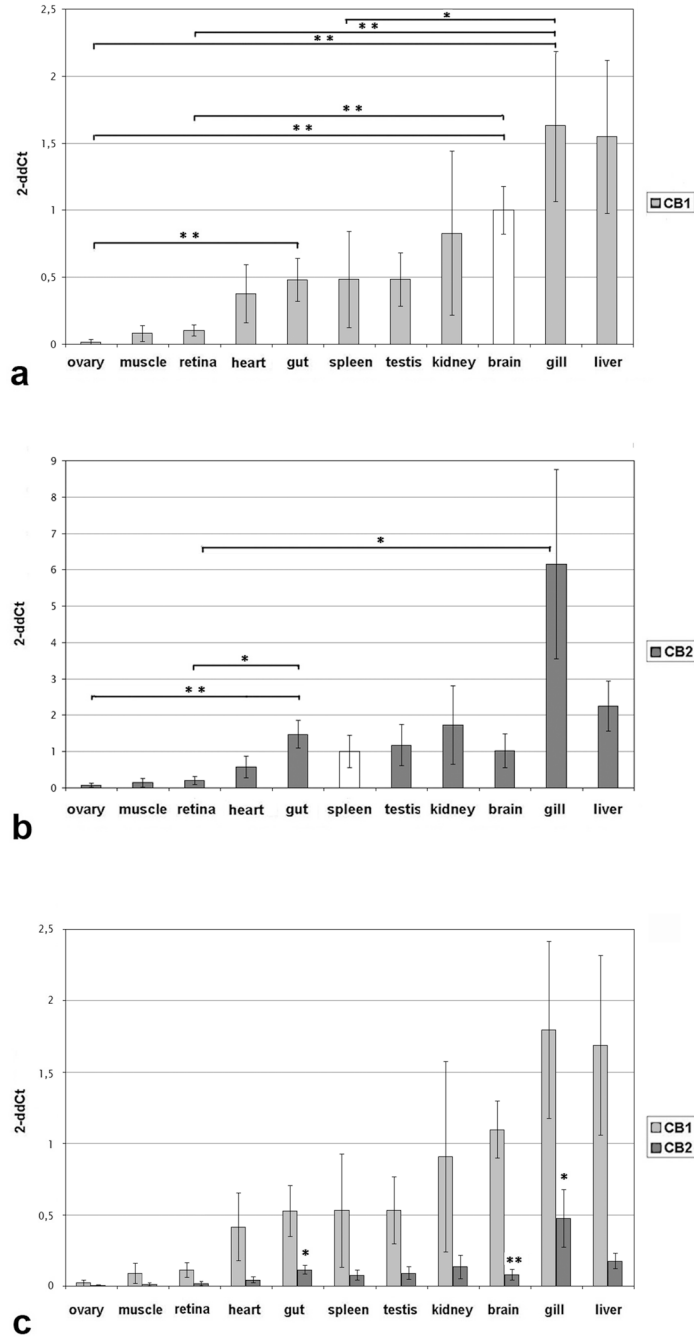

Fig. 4. qReal-Time PCR analysis of **a)** CB1 and **b)** CB2 mRNA expression normalized for the housekeeping gene β -actin in different organs of the goldfish (n=6 animals). Reference organs, i.e. brain for CB1 and spleen for CB2 (white bars), are set equal to 1. Bars indicate the mean 2^{-Ct} value \pm SEM, reflecting the fold change in CB1 or CB2 gene expression in different organs. **c):** Comparison of CB1 and CB2 mRNA levels in different organs of the goldfish. The mean 2^{-Ct} CB2 values were scaled down, considering the different starting amount of cDNA used. Statistical significance is represented by asterisks. *: p 0.05, **: p 0.01.

Table 1

Comparison of goldfish CB2 sequence with other known Vertebrate sequences

a. Amino acid sequence identity							
	<i>Danio rerio</i> CB2 type A	<i>Danio rerio</i> CB2 type B	<i>Fugu rubripes</i> CB2	mouse CB2	rat CB2	human CB2	<i>Carassius auratus</i> CB1 (216 aa)
<i>Carassius auratus</i> CB2 (113 aa)	80.5%	81.4%	57.5%	38.9%	38.1%	38.1%	40.7%
b. Nucleotide sequence identity							
	<i>Danio rerio</i> CB2 type A	<i>Danio rerio</i> CB2 type B	<i>Fugu rubripes</i> CB2	mouse CB2	rat CB2	human CB2	<i>Carassius auratus</i> CB1 (650 bp)
<i>Carassius auratus</i> CB2 (340 bp)	84.1%	83.5%	60.3%	53.2%	52.3%	51.1%	55.1%