

AperTO - Archivio Istituzionale Open Access dell'Università di Torino

Population Diversity in Cuticular Hydrocarbons and mtDNA in a Mountain Social Wasp

This is a pre print version of the following article:

Original Citation:

Availability:

This version is available <http://hdl.handle.net/2318/1532818> since 2016-06-23T10:40:26Z

Published version:

DOI:10.1007/s10886-014-0531-0

Terms of use:

Open Access

Anyone can freely access the full text of works made available as "Open Access". Works made available under a Creative Commons license can be used according to the terms and conditions of said license. Use of all other works requires consent of the right holder (author or publisher) if not exempted from copyright protection by the applicable law.

(Article begins on next page)



UNIVERSITÀ DEGLI STUDI DI TORINO

This is an author version of the contribution published on:
Questa è la versione dell'autore dell'opera: [**Journal of Chemical Ecology DOI 10.1007/s10886-014-0531-0**]

The definitive version is available at:

La versione definitiva è disponibile alla URL:

[<http://link.springer.com/article/10.1007/s10886-014-0531-0>]

POPULATION DIVERSITY IN CUTICULAR HYDROCARBONS AND mtDNA IN A MOUNTAIN SOCIAL WASP

M. Bonelli, M. C. Lorenzi, J.-P. Christidès, S. Dupont, A.-G. Bagnères

Abstract – Nestmate recognition is a common phenomenon in social insects that is typically mediated by cuticular hydrocarbons. Geographical variation in cuticular hydrocarbons has been observed, although the pattern of variation is not consistent across species and is usually related to the biology and ecology of the different species. *Polistes biglumis* (Hymenoptera: Vespidae) is a social wasp that lives in high mountains where populations are separated by important geographical barriers. Here we investigated the level of chemical variation among populations of *P. biglumis* in the Alps and shed light on the phylogeography of this species. Populations could be discriminated by means of their cuticular hydrocarbon profiles, which showed a pattern consistent with the isolation-by-distance hypothesis. Molecular data highlighted two areas with different levels of haplotype diversity, although all wasps belonged to the same species. These results suggest that the populations of *P. biglumis* in the Alps are geographically isolated from one another, favoring their genetic and chemical differentiation.

Key Words – Cuticular hydrocarbons, mtDNA, *Polistes biglumis*,

Chemical distances, Geographical distances, Paper wasps

Introduction

Animal communication is one of the most fascinating subjects in evolutionary biology that can involve different sensory channels and can occur at different levels of organization (i.e. interspecific, intraspecific, intra-colonial). It necessarily involves the interaction of two individuals, a sender and a receiver, and the transmission of a signal. Few phenotypes are as diverse as signals used in intraspecific communication (Campbell et al. 2010) and the natural variation in these signals provides a means for examining the factors contributing to the evolution of communication systems (Wilczynski and Ryan 1999). Among the different levels of variation observed, geographic variation provides an ideal material for disentangling the myriad of factors shaping the evolution and divergence of communication systems (Wilczynski and Ryan 1999). Since signal evolution is rarely explained by a single selective force (Campbell et al. 2010), ecological factors, genetic drift in isolated population, and patterns of gene flow across a species range, likely interact in complicated ways to yield the geographically changing profile of communication characteristics seen in many species (Wilczynski and Ryan 1999). Acoustic communication has been found to vary geographically in several animal groups, including mammals, birds, frogs and insects (e.g. Campbell et al. 2010; Castellano et al. 2000) and in many cases animals discriminate between geographic variants of their signals (Searcy et al. 2001). Large geographic variation is also present in visual signals, as for

example in the extent of orange and black color in male guppies (Endler 1995) and in the facial patterns of paper wasps (Tibbetts et al. 2011). Several studies further found geographic variation in chemical communication cues, as in moth pheromone blends (Groot et al. 2009) and in salamander courtship pheromones (Rollmann et al. 2000). Geographic variation in communication systems is thus widespread and could play an important role in population and species divergence. In some social insects, geographic variation has been observed in cues involved in nestmate recognition (e.g. Dapporto et al. 2004; Martin et al. 2011; Perdureau et al. 2010; but see Martin et al. 2008b). Social insects form colonies that are usually closed to all but nestmates (Wilson 1971). Since these colonies contain many attractive resources, as shelters, food stores, eggs and brood, they are the target of many potential intruders. Social insects have evolved highly sophisticated mechanisms to defend their colonies. The main mechanism is nestmate recognition, that is mainly mediated by chemical communication through cuticular hydrocarbons (Blomquist and Bagnères 2010; Howard and Blomquist 2005). Cuticular hydrocarbon (CHC) profiles of social insects are species-specific and differ qualitatively between species and quantitatively within species (Howard and Blomquist 2005). CHC profiles are usually composed of several compounds: linear and branched alkanes and alkenes (Howard and Blomquist 2005). Methyl-branched alkanes and alkenes are especially important for discriminating between nestmates and non-nestmates (Châline et al. 2005; Dani et al. 2005; Lorenzi et al. 2011), whereas linear alkanes are more involved in

protection against desiccation (Gibbs and Rajpurohit 2010). However, both methyl-branched alkanes and linear alkanes have also been found to function as queen pheromone (Holman et al. 2013b; Van Oystaeyen et al. 2014).

Within species, CHC mixtures change with respect to age, sex, geographic location, but also caste, rank, task and colony (Nunes et al. 2009; Sledge et al. 2001). Variation in CHCs has been used to differentiate populations (Nowbahari et al. 1990; Perdereau et al. 2010), but data on geographical patterns are conflicting. Geographic variation in CHCs has been found in *Drosophila montana* (Jennings et al. 2014) and, in the termite *Reticulitermes lucifugus*, colonies from the same area showed similar profiles, but differences did not always increase with distance (Uva et al. 2004). However, Uva et al. (2004) found a geographic trend in alkene content, which decreased from the north to the south of Italy. In *Formica exsecta* ants, differences in linear alkanes between populations increased with spatial distance at a local scale, while (Z)-9-alkene compounds did not, despite their involvement in nestmate recognition (Martin et al. 2013). Environmental factors, sex and physiological status (e.g. age and fertility) play an important role in shaping CHC profiles (e.g. Bonavita-Cougourdan et al. 1991; Cuvillier-Hot et al. 2001; Howard and Blomquist 2005; Van Oystaeyen et al. 2014), but genotype can also affect CHC composition. Understanding the genetics of insect hydrocarbons is far from being complete and only few studies have identified genes involved in CHC biosynthesis and regulation (Dallerac et al. 2000; Eigenheer et al. 2002). Thomas and Simmons (2008) provided evidence for a

genetic basis of the CHC profile in crickets and correspondence between CHC patterns and genetic variation has been found in termites (Dronnet et al. 2006). Argentine ants also use genetic labels, such as heritable odor cues, to identify individual group membership (Tsutsui et al. 2003). Therefore, both genetic and environmental factors influence CHC profiles (Liang and Silverman 2000; Nielsen et al. 1999; Page et al. 1991). Nests that are close geographically may also be close genetically and may experience similar environmental conditions. Nevertheless, the nature of the relationship between geographic closeness and variation in CHC profile is not consistent across species and differentiation among populations can be due to several accidental and non-accidental factors, including genetic drift, mutations, non-random matings, gene flow and/or selection.

The genus *Polistes* is a large cosmopolitan taxon of paper wasps with species that have adapted to a wide range of environments (Yamane 1996). They have an extremely wide geographic distribution and are primitively eusocial (they lack morphological castes) (Pardi 1996). Colonies are founded independently by single foundresses or by associations of several foundresses, with an annual colony cycle, where reproductive individuals usually emerge towards the end of the nesting period (Yamane 1996). They are excellent study systems, as they build small, uncovered, single-combed nests that are often found in aerial positions (Reeve 1991). *Polistes* wasps are a model system for the study of nestmate recognition and it has been shown that this process is mainly mediated by methyl-branched alkanes and alkenes (Dani et al. 2001; Lorenzi

et al. 2011). Interestingly, in *Polistes* the nest is essential for the learning of the colony odor and young wasps learn their colony odor from nest paper soon after emergence (Gamboa 2004). The CHC profile varies between Tuscan populations in the paper wasp *Polistes dominula*, whereby individuals from neighboring localities have more similar epicuticular profiles than those from distant localities (Dapporto et al. 2004). CHCs have been successfully used to study biogeographic patterns in the same species in the Tuscan Archipelago, but no significant correlation between chemical and geographical distances was found (Dapporto et al. 2009).

Our study model is a *Polistes* wasp with rare characteristics among its genus. *Polistes biglumis* inhabits cooler environment compared to other *Polistes* species and has a boreomontane distribution (Pekkarinen and Gustafsson 1999), but up to now nothing is known about the phylogeography of this species. In southern Europe, *P. biglumis* has a patchy distribution and is found in open, mountain meadows at elevations above 1200 m a.s.l (meters above sea level). Due to the rigid environmental conditions, the colony cycle is reduced to 3-4 months, starting at the end of May and ending before mid- September (Lorenzi and Turillazzi 1986). *P. biglumis* colonies are always founded by a single foundress, that is responsible for colony odor (Lorenzi et al. 2011). Interestingly, this species does not have the typical caste succession present in temperate *Polistes*, and females from the first emerging brood are physiological equipped for becoming foundresses during the next season (Fucini et al. 2009). As other *Polistes* species, *P. biglumis* foundresses are

philopatric (review in Reeve 1991; Hunt 2007) and a recent molecular study has shown that they mate locally (Seppa et al. 2011). Lorenzi and Thompson (2011) found that four populations of this species differed in morphological and life-history traits, while Fucini et al. (2014) found geographic differences in foundress behavior. *P. biglumis* wasps promptly discriminate between nestmates and non-nestmates and discrimination is mediated by CHCs (Lorenzi et al. 1997; Uboni and Lorenzi 2013). The life-history characteristics of *P. biglumis* and the geomorphology of the landscapes that it inhabits (important geographic barriers and vast areas unsuitable for nesting) are likely to keep its populations separated and make this species a perfect model to test how CHC profiles diverge between populations and which selective pressures fuel this process.

The purpose of this study was to assess the level of chemical variation in CHC profiles among populations of *P. biglumis* collected in a vast area of Western and Central Alps. Our aim was to investigate the presence of a pattern of isolation by distance (Wright 1943) in the variation of CHC profiles, identify the compounds involved in the differentiation and shed light on the phylogeography of this species.

Methods

Field Sites and Study Populations We collected 51 *P. biglumis* nest foundresses from 13 populations geographically separated by up to 330 km distance, across the Italian, Swiss and French Alps. Populations were between 1300-1950 m a.s.l., where the

environment is typically Alpine, with woods of *Pinus silvestris*, *Larix decidua*, *Juniperus*, *Rhododendron* and wide meadows. Collections were made between June 6 and July 27, 2011. All but 12 foundresses were from colonies in pre-emergence period (i.e., when the single foundress is the only adult wasp on the nest) (foundresses from post-emergence colonies were roughly equally distributed among populations). Ten populations belonged to the Western Alps and three to the Central Alps (Table 1).

Chemical Procedures For chemical analyses, 45 foundresses from 9 populations were used (populations containing less than 4 foundresses were not used for chemical profiling). Foundresses were killed by freezing and stored at -18 °C until use for chemical and molecular analyses. Each wasp was weighted with a precision balance Precisa 125A and then we extracted cuticular compounds by dipping each frozen wasp in 1 ml pentane for 60 sec. Extracts were then dried under a gentle nitrogen stream and re-eluted in 100 µl of pentane containing an internal standard (*n*-C₂₀). For each extract, 2 µl sample were injected in the gas chromatograph. Hydrocarbons were quantified by gas chromatography (GC) and identified by both comparison of their retention times with those recorded earlier for females of the same species (Lorenzi et al. 1997) and by gas chromatography – mass spectrometry (GC-MS). Quantitative analyses were performed with a 6850 Network system (AGILENT Technologies Santa Clara CA 95051, USA), with a flame-ionization detector, and a HP 5MS capillary column (5% phenyl, 95% dimethylpolysiloxane, 30 m x 0.25 mm ID; 0.25µm film,

AGILENT J et W), eluted with helium at a flow rate of 1.2 mL/min. Two μl of each sample were injected at 250 °C, in the splitless mode for 2 min. Oven temperature increased from 70 °C to 150 °C at a rate of 30°/min and from 150 °C to 320 °C at a rate of 5°/min. The final temperature of 320 °C was kept for 10 min. Results were registered in an Agilent ChemStation. Areas of the main peaks were integrated using GC ChemStation ver. B.04.02.sp1 software (Agilent Technologies) and corrected manually.

Qualitative analyses were performed with a Perkin Elmer (Waltham, Massachusetts 02451, USA) Autosystem gas chromatograph, coupled to a TurboMass mass spectrometer instrument. Separation was achieved using the same column and program used for GC analyses. Data were acquired and processed using TurboMass ver. 5.4.2.1.1617 software (Perkin Elmer). Compound identification was performed after electron impact (70 eV) with a program of scanned masses of mass-to-charge ratio (m/z) from 45 to 500. Results were compared with data obtained previously (Bagnères et al. 1996; Lorenzi et al. 1997; Uboni et al. 2012) and profile parts with coeluting peaks were verified on the total ion chromatogram obtained by GC-MS.

Table 1 Geographic location of the sampled populations of *P. biglumis* in the Alps

Population	Area	Altitude (m asl)	Latitude	Longitude	Code	ID number	wasps for CHC analyses	wasps for COI analyses
Lago della Rovina	Western Alps	1,530	44°10'	7°20'	ROV	6	4	4
Valle Pesio	Western Alps	1,400	44°11'	7°37'	PE	13	-	1
Terme di Valdieri	Western Alps	1,360	44°12'	7°16'	VAL	8	5	5
Ferrere	Western Alps	1,900	44°22'	6°57'	FER	4	4	4
Fondovet	Western Alps	1,530	44°34'	7° 8'	FUN	5	4	4
Sanpeyre	Western Alps	1,300	44°35'	7°10'	COL	12	-	1
Alpe Plane	Western Alps	1,900	44°53'	6°56'	AP	1	4	4
Thures	Western Alps	1,700	44°54'	6°49'	TH	11	-	2
Montgenèvre	Western Alps	1,850	44°55'	6°43'	MTG	7	7	4
Cesana	Western Alps	1,370	44°57'	6°47'	CES	10	-	2
Cari	Central Alps	1,700	46°29'	8°49'	CAR	3	6	6
Campovecchio	Central Alps	1,300	46° 8'	10°11'	CAM	2	7	7
Trivigno	Central Alps	1,700	46°11'	10°11'	TRI	9	4	4

Chemical Analyses

For each foundress, the areas of peaks of the gas-chromatogram were transformed into relative proportion with respect to the

total CHC area. For statistical analyses, we selected those compounds whose average proportion among all samples was $\geq 0.5\%$. Both stepwise and non-stepwise Discriminant Analysis (DA) were run to determine whether populations could be discriminated based on their chemical profiles. The grouping variable was the population of membership and the independent variables were the chemical compounds (within-group covariance matrix). Because the relative amounts of compounds are compositional data, they were transformed prior to the DA analyses, following the Aitchison transformation (Aitchison 1982). We performed a Mantel test using the Vegan package of the software R 2.15.1 to test for a correlation between chemical and geographical distances among populations (P value based on 100.000 resampling). Euclidean dissimilarities were used to estimate chemical distances among population and Z-scores were used to standardize percentages (compounds $\geq 0.5\%$). The chemical distance between two populations was calculated as the mean distance among all pairs of foundresses belonging to the two populations, and this was done for each possible pair of populations. Geographical distances between populations were calculated as the shortest distance connecting each pair of populations.

Molecular Procedures One leg of each of the 51 foundresses was cut and stored in 96% ethanol at 4°C until DNA extraction. Genomic DNA was extracted using Wizard®

Genomic DNA Purification Kit (Promega) according to the manufacturer's instructions. A 658 bp portion of the COI gene

was amplified from each individual using the primers LCO1490 (5'-GGTCAACAAATCATAAAGATATTGG-3') and HCO2198 (5'-TAAACTTCAGGGTGACCAAAAATCA-3') (Folmer et al. 1994). PCR amplifications were performed with HotstarTaq[®] Master Mix Kit (Qiagen) using a Biometra 96 T1 thermal cycler with an initial denaturation step at 95°C (2 min) followed by 35 cycles at 94°C (45 sec), 53°C (1 min) and 72°C (1 min 30 sec) and finally by an extension step at 72°C (10 min). The PCR templates were purified with NucleoSpin[®] Gel and PCR Clean-up kit (Macherey-Nagel) and sequenced on an automated ABI 3100-Avant sequencer using Big Dye[®] v3.1 Terminator cycle sequencing kit. Both strands of PCR products were sequenced. Sequences were aligned using the ClustalW algorithm (Thompson et al. 1994) within the software Geneious[®] Pro 5.6.6 and corrected manually. Sequences were then deposited in GenBank under the accession numbers KM017013 to KM017061.

Phylogenetic Analyses COI sequences were analyzed using three different phylogenetic analysis methods: neighbor-joining (NJ), maximum-likelihood (ML) and Bayesian methods of inference (BI). The NJ method was applied using PHYLO_WIN (Galtier et al. 1996) and the ML method using PhyML (Guindon and Gascuel 2003). The neighbor-joining analysis was conducted using the Kimura 2 parameter distance option. MrAIC was used to find an appropriate sequence evolution model for the data (GTR+IG) (Nylander 2004). BI was carried out using MrBayes 3.1.2 (Huelsenbeck and Ronquist 2001), running it for 5000000 generations. No a priori assumptions about tree

topology were made, and analyses were performed using uniform priors. All sequences were analysed using four species as outgroup: *Polistes gallicus* (Genbank Number GU596875), *P. dominula* (HQ947784), *P. nimpha* (EF136448) and *P. chinensis* (JN276772). The relationships between haplotypes were represented as a haplotype network obtained using the TCS version 1.21 with a 95% confidence limit (Clement et al. 2000). Two wasps were finally excluded from the analyses for technical problems.

Results

We identified 72 peaks in the CHC mixture of *P. biglumis* foundresses as previously determined (Uboni et al. 2012) (Table S1). Components were mainly saturated hydrocarbons: *n*-alkanes, laterally and centrally branched monomethylalkanes, dimethylalkanes and trimethylalkanes; alkenes were present only in traces. Each peak represented either a hydrocarbon or a mix of positional isomers. CHC chain length ranged from 23 to 35 carbon atoms. Some peaks that coeluted were quantified together (9).

Chemical analyses Foundresses from the nine populations differed quantitatively in their cuticular hydrocarbon profiles. All foundresses (100%) were correctly assigned to their population by the DA (Fig.1). The first two DA functions explained 68.9% of the total variance (function 1: canonical correlation = 0.982, Wilks' Lambda < 0.001, X² = 331.007, P < 0.001; function 2: canonical correlation = 0.971, Wilks' Lambda < 0.001, X² = 251.197, P = 0.027). All peaks were nearly equally important for

the discrimination and all had low and similar loadings on the two functions (function 1: loadings between - 0.095 and + 0.107, function 2: loadings between - 0.121 and + 0.092). It was not possible to run a stepwise DA because no compounds reached the F level to be entered in the analysis, suggesting that all compounds contributed to the discrimination. The populations of the Western and Central Alps were roughly separated along the diagonal of the plot built on the first two discriminant functions (Fig. 1).

Fig. 1 Plot of the results of the Discriminant Analysis showing the relative position of all 45 *Polistes biglumis* foundresses from the nine populations in the DA space. The diagonal line has been added arbitrary for representative purpose to show the separation between the chemical profiles of the wasps from populations of the Western (on the right) and Central (on the left) Alps (see Table 1 for populations codes).

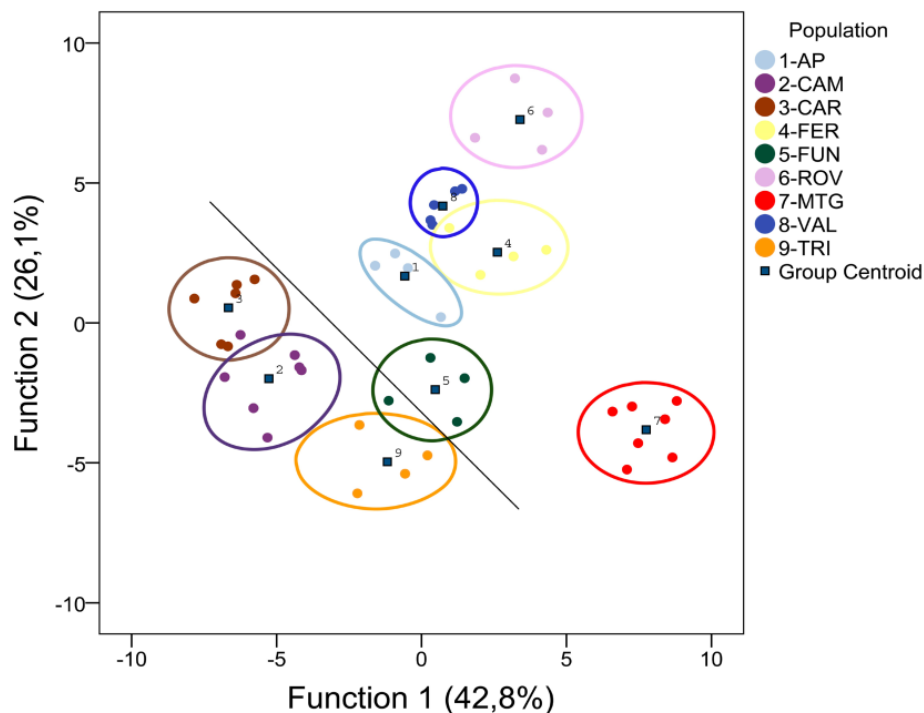

There was a strong correlation between chemical and

geographical distances between populations when chemical distances were calculated either for all compounds or for branched compounds only (Mantel test: all compounds: $r = 0.439$, $P = 0.007$; branched compounds: $r = 0.452$, $P = 0.007$). Significance decreased when chemical distances were calculated for linear hydrocarbons only ($r = 0.441$, $P = 0.01$) (Fig. 2).

Fig. 2 Correlation between pairwise geographic and chemical distances (all compounds) of the populations of *P. biglumis*. Each dot represent a pair of populations.

Molecular and Phylogenetic Analyses Phylogenetic trees reconstructed using three different methods (NJ, ML and BI) showed congruent topologies, where samples formed a monophyletic group and two major clades were identified (clades I and II) (Fig. 3). We determined 14 unique haplotypes based on the 15 variable sites identified

28

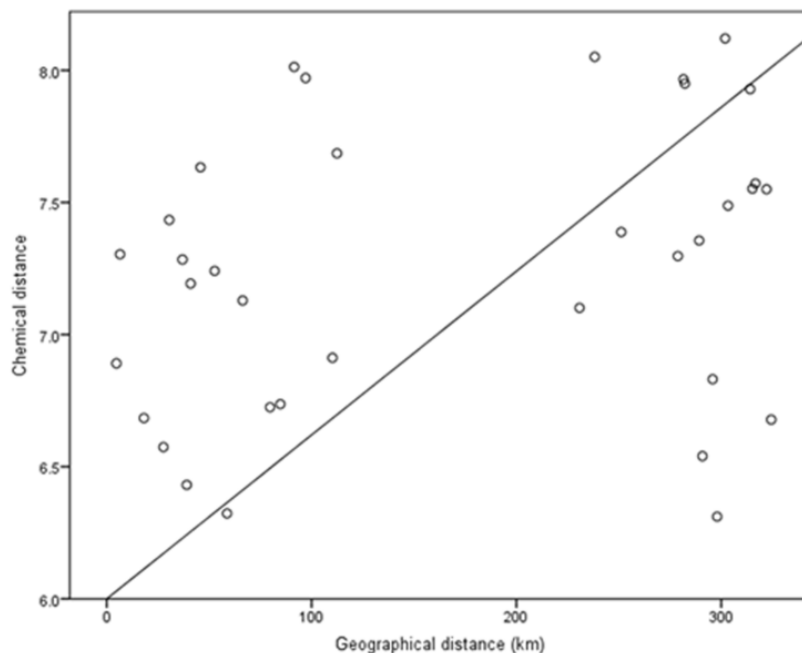

Chapter 2_Population diversity in CHCs and mtDNA

from the 49 aligned individual-based COI sequences. The haplotype network revealed three haplotype groups similar to those

observed using phylogenetic methods (Fig. 3). Among the haplotype groups one was very variable and included 12 haplotypes, 9 of which represented by only one foundress. All wasps from Central Alps (with one exception) shared the same haplotype and this haplotype was virtually lacking in the Western Alps.

Discussion

Chemical profiles of *P. biglumis* varied quantitatively among populations situated roughly across a longitudinal gradient. Moreover, chemical profiles showed a pattern consistent with the isolation by distance hypothesis, (i.e. when there are only short range means of dispersal, remote populations may become differentiated merely from isolation by distance, Wright 1943). Chemical and geographical distances among populations were correlated, meaning that the largest the geographical distance between two populations, the largest their chemical differences in CHCs. To our knowledge this is one of the first extensive surveys on the geographical variation in the CHC profiles in social wasps and it is the first evidence of geographic variation in the chemical profiles of *P. biglumis*.

Our findings are better explained if we consider the biogeography of this species. Pleistocene glacial periods strongly affected species distribution over large part of their geographic ranges (Triponez et al. 2011). Cold adapted species, that were probably widespread during glacial maxima, should be restricted to remote environment during interglacial periods, as at present *P. biglumis* lives in Northern Europe (Sweden, Norway) (rarely

found), central and Southern Europe (Spain, Italy), North Africa (rarely

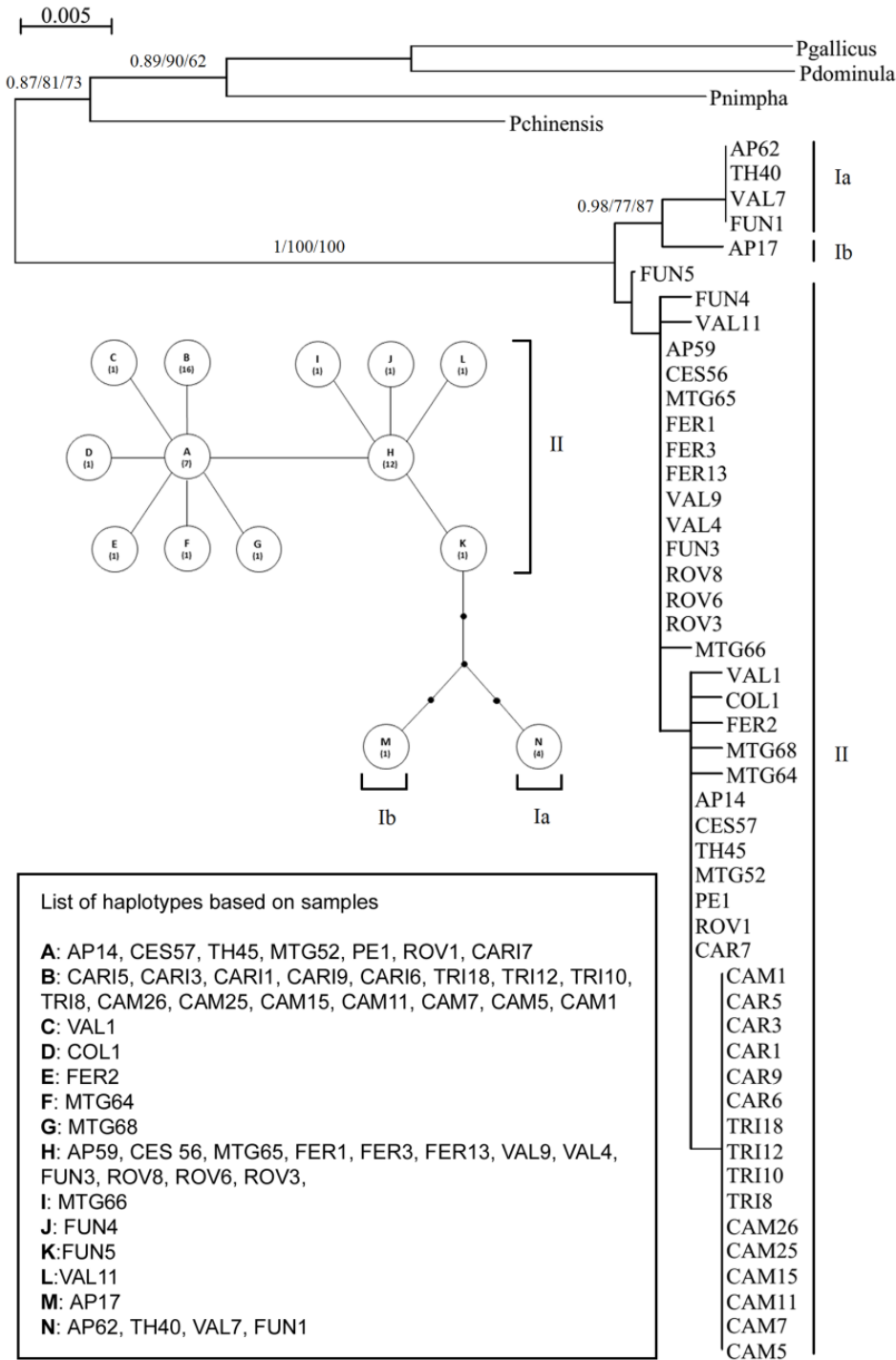

found) and Western Asia (Guiglia 1972). In Southern Europe *P.*

biglumis is limited to mountain zones and to Alps and Apennines in Italy (Guiglia 1972). In the mountains, *P. biglumis* populations are separated by geographical barriers and foundresses tend to be philopatric and mate locally (Seppä et al. 2011). Gene flow among populations should, therefore, be low and should decrease with increasing geographical distances. Distant populations should thus be more genetically diverse than close populations. Since CHCs have important heritable component (Thomas and Simmons 2008; Tsutsui et al. 2003), the pattern of isolation by distance that we found in CHC profiles is not surprising.

Chemical distances calculated on linear hydrocarbons and those on branched hydrocarbons were both significantly correlated with geographical distances. However, evidence exists of different patterns. In *Formica exsecta* the chemical distances of *n*-alkanes correlated with spatial distances at a local scale, while those of (*Z*)9-alkenes, which are responsible for nestmate recognition in this species, did not (Martin et al. 2013). While branched alkanes and alkenes are especially important for nestmate recognition (Châline et al. 2005; Dani et al. 2001; Lorenzi et al. 2011; Martin et al. 2008a, 2008b), linear alkanes are mainly involved in protection from water loss (Gibbs and Rajpurohit 2010). It is possible that linear and branched CHCs are linked to different parts of the genome and are under different selection regimes.

Data on variation in CHC profiles in paper wasps are conflicting. One study showed that *Polistes dominula* wasps from

neighboring localities in Tuscany had more similar CHC profiles than those from distant ones (Dapporto et al. 2004), but no correlation was found between chemical and geographical distances in a wider survey on the same species in the Tuscan Archipelago (Dapporto et al. 2009). The lack of correlation was interpreted as an indication of the importance of environmental influences on CHC profiles (Dapporto et al. 2009). However, unlike *P. biglumis*, *P. dominula* has a widespread distribution in lowland of Central and Southern Europe (Cervo et al. 2000) and its populations might have high gene flow.

Knowledge about environmental influences on CHCs is increasing quickly and many studies on both social and non-social insects have shown that CHC profiles can be affected by environmental factors such as season (Nielsen et al. 1999), diet (Buczkowski et al. 2005), or temperature and rainfall regimes (Parkash et al. 2008a). Dietary effects on CHC profiles were found in a wide range of insects (Buczkowski et al. 2005; Richard et al. 2004; Steiger et al. 2007), however, in *Polistes* wasps, data on the effects of seasonal changes and diet on CHC profiles is lacking. *Polistes* is known to prey upon caterpillars, slow-moving insects, fruits and nectar (Akre 1982). Variability in the availability of certain food types might account for some of the variation between populations in *P. biglumis* CHC profiles. Data on CHC profiles in relation to temperature and humidity are less straightforward. For instance, Parkash et al. (2008a) found that temperature and humidity affected the cuticular lipid layer in the fly *Zaprionus indianus*, while studies on ants found no or

conflicting evidence for climatic effects on CHC profiles (Menzel and Schmitt 2012; van Wilgenburg et al. 2011). However, a recent study on *P. biglumis* showed that abiotic factors such as rainfall regime and local temperature were poor predictors of the divergence in CHC signature between populations, whereas biotic factors, such as social parasite prevalence, could play a role in the differentiation (Lorenzi et al. 2014).

Phylogenetic analyses showed a distinct monophyletic grouping of mitochondrial COI haplotypes, thereby confirming species identity. Indeed, several studies using molecular analyses showed the presence of previously- unknown cryptic species in insects (Anderson et al. 2013; Molbo et al. 2003) and especially the COI is widely recognized as an effective tool for species delimitation (Anderson et al. 2013). This is, to the best of our knowledge, the first evidence confirming the status of species among *P. biglumis* wasps from different geographical areas.

COI sequences showed low intra-specific variation and two main clades were identified. Within the 2 clades it was possible to differentiate 3 haplotype groups and 14 haplotypes, some of which showed only a single base variation and were represented by a single foundress. Haplotype diversity varied between the Western and Central Alps: while in the Western Alps 13 haplotypes were found, in the Central Alps only 2 haplotypes were found. Moreover, populations belonging to the two geographic areas were clearly genetically differentiated and the foundresses belonging to the Central Alps had their own haplotype (B), which was virtually absent in the foundresses

belonging to the Western Alps (Fig. 4). We performed both a neighbor-joining analysis and a hierarchical clustering analysis on chemical data (analyses not shown), but wasps from the same population did not cluster together and also the different geographical areas were not clearly separated. This may be due to the high individual variation in the chemical profile (within and between populations variances are similar, unpubl. data). The fact that trees built on genetic data and those built on chemical data do not match suggests that in *P. biglumis* the COI gene variation is not representative of the genetic variation in CHCs.

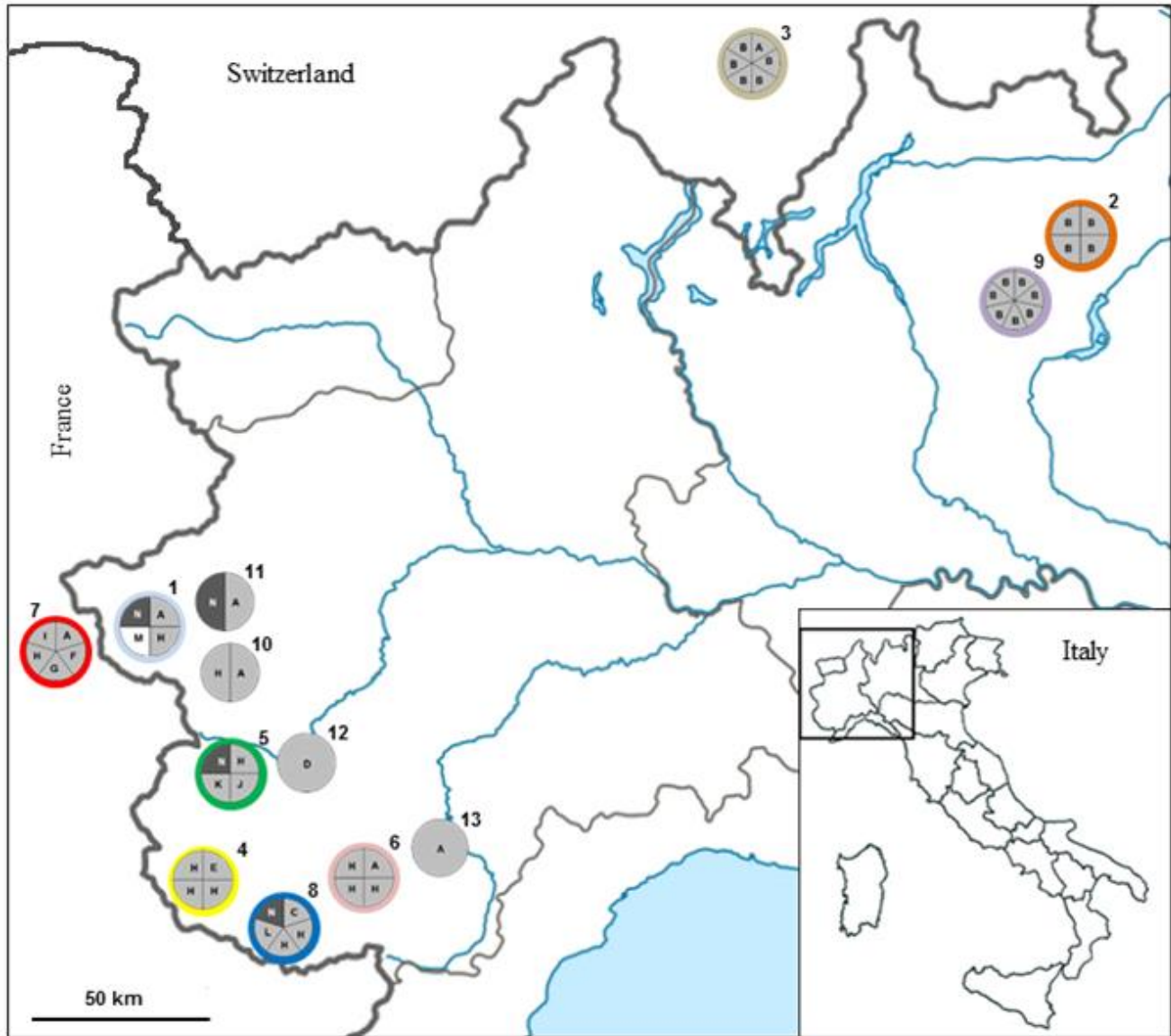

Fig. 4 Map of the populations of *P. biglumis*. Letters inside circles represent the haplotypes found in the 13 populations. Shades of gray inside circles represent the membership of the haplotypes to one of the three haplotype groups (dark gray: Ia; white: Ib; light gray: II). Colors around circles indicate the 9 populations for which we analyzed the chemical profiles. Circles without color around them are populations for which we did not analyze the chemical profile. Numbers in the upper right of circles are the ID numbers for populations (see Table 1).

Indeed, while some studies found a match between genetic and chemical variation (Dapporto et al. 2009, Dronnet et al. 2006,

Jenkins et al. 2000), others did not (Marten et al. 2009).

The low haplotype diversity in the Central Alps can be explained by stochastic processes (i.e. founder effect, genetic drift, bottlenecks) and/or selective processes (i.e. hitch-hiking effect). To date we have no evidence for the respective weight of these processes. We can speculate that the Western Alps could represent an ancestral area for *P. biglumis*, while the Central Alps area would have been more recently colonized. Our data could also suggest a different origin for populations of the two areas: for example, the Central Alps populations might originate from eastern or northern populations (e.g. Balkans and/or Central Europe), whereas the Western Alps populations could originate from Western Europe (e.g. Pyrenees and/or Massif Central). However, we need an enlarged dataset and a wider sampling area in order to evaluate these different scenarios or new ones. These results are the first data on the phylogeography of *P. biglumis* and give us interesting insights on the biology of this species. They seem to confirm previous knowledge regarding the philopatry of *Polistes* foundresses. Moreover, they suggest the possibility of a founder effect, genetic drift, bottlenecks and/or hitch-hiking effect. Future studies analyzing other molecular markers (mitochondrial and nuclear genes) and investigating gene flow among populations will increase our knowledge of the genetic variation and spatial structure in the populations of *P. biglumis* in the Alps. This knowledge will in turn help us to disentangle the factors which contribute to between-population variation in the chemical profiles. In social insects, CHC profiles mediate nestmate

recognition and therefore are of crucial importance for the survivorship and success of the colony. Indeed, the cost of being exploited selects for colonies that can efficiently defend themselves against the attacks of intruders. Moreover, chemical profiles are involved in processes other than recognition, as prevention from desiccation and protection from pathogens (Howard and Blomquist 2005). Physiological constraints, as well as ecological characteristics (e.g. abiotic factors and the social environment), can shape the evolution of chemical profiles. Understanding the evolution of chemical communication as a whole requires knowledge of how selective pressures may vary depending on local conditions and local interactions among species. Extensive surveys that simultaneously investigate chemical, genetic, social and environmental aspects are therefore needed to understand which factors affect the geographical variation in the CHC profiles in social insects.

* This study has been published in the *Journal of Chemical Ecology* (2015) 41:22–31, DOI 10.1007/s10886-014-0531-0. The published paper is included as annex.