

AperTO - Archivio Istituzionale Open Access dell'Università di Torino

### The First Level Trigger of JEM-EUSO: Concept and tests

**This is a pre print version of the following article:**

*Original Citation:*

*Availability:*

This version is available <http://hdl.handle.net/2318/1636685> since 2017-05-19T15:57:56Z

*Published version:*

DOI:10.1016/j.nima.2015.10.044

*Terms of use:*

Open Access

Anyone can freely access the full text of works made available as "Open Access". Works made available under a Creative Commons license can be used according to the terms and conditions of said license. Use of all other works requires consent of the right holder (author or publisher) if not exempted from copyright protection by the applicable law.

(Article begins on next page)

# The first level trigger of JEM-EUSO: concept and tests

M. Bertaina<sup>a,\*</sup>, R. Caruso<sup>b</sup>, O. Catalano<sup>c</sup>, G. Contino<sup>b</sup>, F. Fenu<sup>a</sup>, M. Mignone<sup>a</sup>, R. Mulas<sup>a</sup>, for JEM-EUSO Coll.

<sup>a</sup>Department of Physics, University of Torino & INFN Torino, Torino, Italy

<sup>b</sup>Department of Physics, University of Catania & INFN Catania, Catania, Italy

<sup>c</sup>INAF-IASF Palermo & INFN Catania, Palermo, Italy

---

## Abstract

The trigger system of the JEM-EUSO telescope should face different major challenging points: a) to manage a large number of pixels ( $\sim 3 \cdot 10^5$ ); b) to use a very fast, low power consuming, and radiation hard electronics; c) to achieve a high signal-to-noise performance and flexibility; d) to cope with the limited down-link transmission rate from the ISS to Earth. The general overview of the first trigger level for cosmic ray detection is reviewed; tests that validate its performance are discussed.

*Keywords:* Front End, Trigger, DAQ and Data Management, JEM-EUSO

*PACS:* 29.85.Ca, 96.50.sd

---

## 1. Introduction

JEM-EUSO is a space mission devoted to the investigation of Extreme Energy Cosmic Rays and Neutrinos ( $E > 5 \cdot 10^{19}$  eV) from the International Space Station (ISS) [1]. The telescope is formed by a system of three Fresnel lenses and a focal surface filled with multi anode photomultipliers read by a front-end electronics based on the single photon counting [2]. The Focal Surface (FS) detector of JEM-EUSO is organized in 137 Photo-Detector Modules (PDM), composed by 9 Elementary Cells (EC) which assemble together 4 Multi-Anode Photomultipliers (MAPMT) of  $8 \times 8$  pixels each. The Gate Time Unit (GTU) is set at  $2.5 \mu\text{s}$  as a compromise between the available data budget, power consumption and transit time of a signal inside the FoV of a pixel (0.5 - 0.6 km at ground, depending on the FS location). The total amount of data that the electronics has to deal with is of  $\sim 3.2 \cdot 10^5$  pixel/FS  $\times 4 \cdot 10^5$  GTU/s  $\times 8$  bit/pixel  $\sim 1$  Tbps. However, the telemetry budget of the JEM Exposed Facility (JEM/EF) is of  $\sim 300$  kbps. This means that a huge data reduction ( $\sim 3 \cdot 10^6$ ) has to be performed on-time by the on-board electronics. Moreover, the limitations imposed by the power budget ( $\sim 1$  kW for the entire telescope) and space requirements (radiation hard electronics) contribute to make such task even more challenging. In order to satisfy the data-budget requirement, the trigger system to detect cosmic rays is organised in two successive levels. The 1<sup>st</sup> Level Trigger (FLT) operates at EC level, which is the basic unit of the front-end electronics. Its main aim is to reduce the rate of fake triggers to  $\sim 1$  Hz/EC. The most dominant component of the fake triggers is background fluctuations causing accidental coincidences. Among other causes are: anthropogenic lights, lightnings, meteors, aurorae. The 2<sup>nd</sup> Level Trigger (SLT) is designed to operate at PDM level and it is expected to further

reduce the trigger rate to  $\sim 0.1$  Hz/FS [3]. The principle to distinguish an Extensive Air Shower (EAS) event from any other phenomena relies on the basic idea that it travels at the speed of light along a line.

## 2. The First Level Trigger of JEM-EUSO

The FLT rejects most of the background fluctuations by requiring a locally persistent signal above the average background lasting a few GTUs. In this trigger level, pixels are grouped in cells of  $3 \times 3$  pixels. Each inner pixel of a PMT belongs to 9 different cells as it can be the center of a cell or belong to the edges. Therefore, one MAPMT can host up to 36 cells. The cells can not be shared by near-by MAPMTs. If for a certain number of GTUs ( $N_{\text{ctd}}$ ) in a slot of consecutive GTUs ( $P$ ), there is at least one pixel in the cell with an activity (counts) equal to, or higher than, a preset threshold,  $N$ , and the total number of detected photo-electrons in the cell is higher than a preset value  $S$ , a trigger is issued.  $N_{\text{ctd}}$  and  $P$  are set to 3 and 5 GTUs, respectively, while  $N$  and  $S$  are set as a function of the average background level in order to keep the rate of triggers on false positives at  $\sim 1$  Hz/EC.

An EAS is visible in one EC for less than 45 GTUs. This is much shorter than the minimum fraction of time lightning (ms), meteors (hundreds ms) and cities/airplanes (seconds) illuminate 1 EC. Starting from the GTU in which the FLT fires, a confirmation counter is activated. For a preset number of consecutive GTUs ( $N_{\text{GTU}}$ ), the confirmation counter is increased by 1 count each GTU in which the FLT is fired. After  $N_{\text{GTU}}$ , if the confirmation counter has passed a certain threshold  $N_{\text{GTU}}^{\text{thr}}$ , the trigger is not activated because it indicates that the FLT fired for a fraction of time longer than the expected duration of an EAS. Currently,  $N_{\text{GTU}} = 73$  and  $N_{\text{GTU}}^{\text{thr}} = 72$ . However, the two numbers can be set independently. If the value accumulated in the confirmation counter does not reach  $N_{\text{GTU}}^{\text{thr}}$ , the trigger confirmation is issued and the SLT is activated. The FLT gives to

---

\*Corresponding authors

Email address: bertaina@to.infn.it (M. Bertaina)

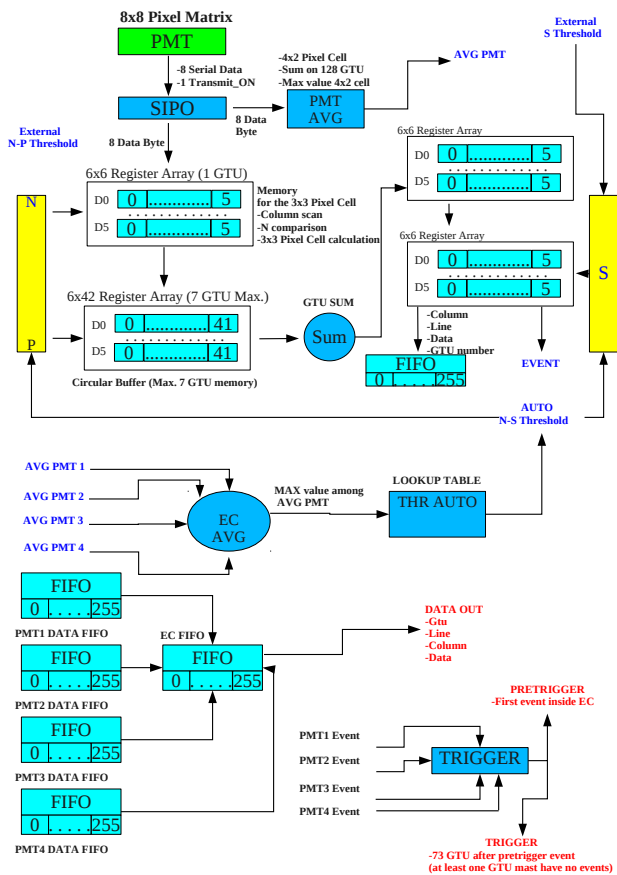

Figure 1: Schema of the VHDL implementation of the FLT logic.

the SLT the information of the time and location of the cells that fired the FLT.

The FLT parameters are set according to the average background level on the MAPMTs. Each EC is subdivided in groups of  $4 \times 2$  pixels, for a total of 32 sub-sections per EC. Every 128 GTUs ( $320 \mu\text{s}$ ) the average count level in each group of pixels is computed. The highest value is used to assign the FLT thresholds for the next 128 GTUs on the entire EC. All the artificial sources like cities, planes, ships can be considered static at this level. In case of JEM-EUSO the FoV at ground of 8 pixels is  $\sim 2 - 3 \text{ km}^2$  depending on the line of sight of the pixels. Therefore, the computation of the background in sub-areas of the EC has two advantages: a) to take into account the non homogeneous response among pixels of the same PMT; b) reduce the probability that an anthropogenic light source causes triggers. This method was validated with experiments at TurLab [4] (see Section 3).

The simulation of the trigger logic here described for one EC has been tested on a Xilinx Virtex6 model XC6VLX240T [5] FPGA and it required  $\sim 7\%$  of its resources. This implies that in principle such FPGA could host all 9 ECs of a PDM.

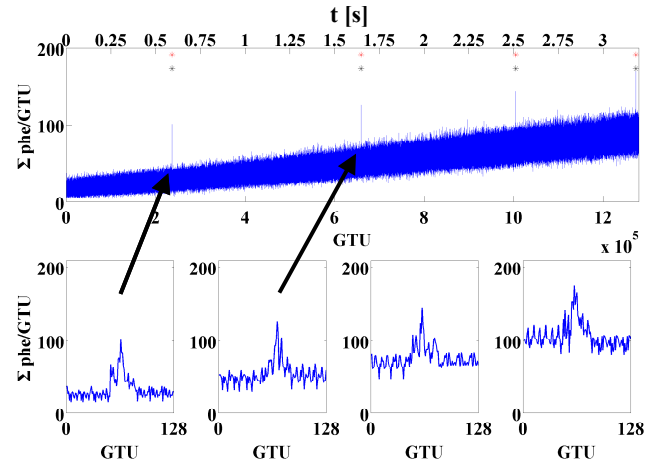

Figure 2: Reproduction of 4 UHECR-like events in 3 seconds of variable background data (see arrows for the first two ones). Stars indicate the timing at which the PTT trigger in the VHDL code was fired.

### 3. Validation at TurLab of First Level Trigger

The concept of the FLT is currently tested and validated using the TurLab facility where the principle of JEM-EUSO observation, data taking and light sources are artificially reproduced in a dark and rotating environment to mimic JEM-EUSO's orbits. A detailed explanation of the setup and tests is reported in [4].

Fig. 2 shows an example of triggered EAS-like events on variable background conditions.

Three seconds of data taking are reported with variable diffused light level between  $\sim 1 - 4$  counts/pixel/GTU, which are the typical counts expected by JEM-EUSO on oceans without moon light [6]. On top of the diffused light level, 4 EAS-like are generated. Each EAS track lasts 35-40 GTUs. Zooms on the 128 GTUs around the events are shown on the bottom of the figure. The stars indicate the time at which FLT occurred is on time with the EAS event. The threshold adjustment on the variable background avoids triggers on the variable diffused light. The EAS events reproduced artificially have comparable shape and intensity of a  $2 \cdot 10^{20}$  eV event detected by JEM-EUSO.

### Acknowledgments

This work was partially supported by the Italian Ministry of Foreign Affairs and International Cooperation. The technical support of G. Cotto, R. Forza, N. Guardone and M. Manfrin during validation tests at TurLab is deeply acknowledged.

### References

- [1] T. Ebisuzaki et al. (JEM-EUSO), Adv. Sp. Res. 53 (2014) 1499–1505.
- [2] M. Casolino et al. (JEM-EUSO), Exp. Astronomy DOI: 10.1007/s10686-014-9418-x, (2014).
- [3] J. Bayer et al. (JEM-EUSO), Proc. 33th Int. Cosmic Ray Conf. (Rio de Janeiro), #0432 (2013); arXiv:1307.7071.
- [4] M. Bertaina et al. (JEM-EUSO), EPJ Web of Conf. 89 (2015) 03003/1-6.
- [5] [http://www.xilinx.com/support/documentation/data\\_sheets/ds150.pdf](http://www.xilinx.com/support/documentation/data_sheets/ds150.pdf)
- [6] J.H. Adams Jr. et al. (JEM-EUSO), Astrop. Phys. 44 (2013) 76–90.