

AperTO - Archivio Istituzionale Open Access dell'Università di Torino

Two-channel combination methods for count-loss correction in radiation measurements at high rates and with pulsed sources

This is a pre print version of the following article:

Original Citation:

Availability:

This version is available <http://hdl.handle.net/2318/1890858> since 2023-02-07T09:54:22Z

Published version:

DOI:10.1016/j.nima.2022.167195

Terms of use:

Open Access

Anyone can freely access the full text of works made available as "Open Access". Works made available under a Creative Commons license can be used according to the terms and conditions of said license. Use of all other works requires consent of the right holder (author or publisher) if not exempted from copyright protection by the applicable law.

(Article begins on next page)

Two-channel combination methods for count-loss correction in radiation measurements at high rates and pulsed sources

Mohammadian-Behbahani, Mohammad-Reza^{1,*}; Monaco, Vincenzo^{2,3,*}; Abujami, Mohammed^{2,3}; Bersani, Davide^{2,3}; Data, Emanuele Maria^{2,3}; Galeone, Cosimo⁴; Giordanengo, Simona³; Hammad Ali, Omar⁵; Marti Villarreal, Oscar Ariel^{2,3}; Mas Milian, Felix^{2,3,6}; Montalván-Olivares, Diango M.^{2,3}; Richetta, Elisa⁷; Staiano, Amedeo³; Stasi, Michele⁶; Vignati, Anna^{2,3}; Cirio, Roberto^{2,3}; Sacchi, Roberto^{2,3}

1. School of Mechanical Engineering, Shiraz University, Shiraz, Iran
2. Università degli Studi di Torino, via Pietro Giuria 1, 10125 Torino, Italy
3. Istituto Nazionale di Fisica Nucleare, sez. di Torino, Via Pietro Giuria 1, 10125 Torino, Italy
4. GSI Helmholtz Centre for Heavy Ion Research GmbH, Darmstadt, Germany
5. Fondazione Bruno Kessler, Centre of Materials and Microsystems, Trento, Italy
6. Universidade Estadual de Santa Cruz, Ilheus, Brazil
7. Azienda Ospedaliera Mauriziano di Torino, Torino, Italy

(*) these authors contributed equally to this work

Corresponding author: vincenzo.monaco@unito.it

Abstract

Two methods are proposed for mitigation of counting inefficiencies due to pile-up effects in radiation measurements with continuous or pulsed fluxes. Both methods are based on the collection of logical signals provided by two independent detectors exposed to the same radiation flux after discriminating the detector analog outputs with a fixed threshold, assuming that the duration of the discriminator output signal corresponds to the system dead-time. The correction algorithms employ the measurement of the time durations and of the number of transitions of the two detector signals and of their AND/OR combinations.

The algorithms are validated using simulations of ideal boxcar functions of fixed duration τ distributed randomly in time to emulate the dead-time behavior of the system. Both methods provide an effective count-loss correction with a maximum deviation of 1% for different input rates (f_{in}) up to $f_{in}\tau = 1$, for a continuous distribution of input pulses for both paralyzable and non-paralyzable systems. The simulation for a pulsed radiation flux provides the same results as a function of the instantaneous input rate.

The methods are intended to correct in real-time inefficiency effects in particle counting measurements of charged particle or photon beams at high rates, but they could be applied in a wider range of applications of radiation measurements, provided a Poissonian statistical distribution of the particle flux.

Keywords

Count-loss correction, Radiation detector, Two-channel combination methods.

1. Introduction

The counting capabilities of radiation detection systems suffer from count-loss induced by pile-up effects when working at high count-rate. This phenomenon is due to the finite dead-time of the detection chain after identifying each event, during which the system is not ready to resolve new events.

The description of counting inefficiencies is traditionally based on two ideal models which describe the saturation behavior of the counting system in case of random pulses with Poisson distribution: the paralyzable and non-paralyzable models [1][2][3][4]. Both models assume a fixed dead-time interval (τ) for the system after the detection of an event, during which other events are not detected. In a paralyzable system the dead time is extended for another interval τ following the lost event, leading, at input frequencies much larger than $1/\tau$, to the system paralysis. On the contrary, in a non-paralyzable system, dead time is not extended for those events occurring during the dead-time leading asymptotically to a constant output frequency $1/\tau$. The relations between the measured number of counts N_{out} and the input number of counts N_{in} in these models are [3][4][5]:

$$N_{out} = N_{in} \exp(-\tau f_{in}) \quad (\text{paralyzable}) \quad (1)$$

$$N_{out} = \frac{N_{in}}{1 + \tau f_{in}} \quad (\text{non-paralyzable}) \quad (2)$$

where τ is the dead-time and f_{in} is the input count rate. Eqs. 1 and 2 can also be formulated in terms of count rates by replacing N_{out} and N_{in} by the measured count rate f_{out} and the input count rate f_{in} , respectively.

So far, several strategies have been proposed for calculating the dead-time corrected input rates, which can be generally classified into three following categories:

- Real-time corrections, in which N_{in} is estimated by inverting the throughput formulae Eqs. 1 or 2 [5][6][7]. In these methods the dead-time τ must be estimated at first.
- Live-time correction, which makes use of a correction factor equal to the ratio of the time the system is free of recording pulses (live time) over the total acquisition time (real time) [5][6][8][9].
- Correction based on time-interval distribution, in which the histogram of counts versus time-intervals of the measured pulses is calculated, then the input count rate can be estimated by fitting the undistorted part of the histogram [6][10][11].

In general, these strategies deal with the following limitations:

- The ideal dead-time models often do not describe a realistic system. In these cases real-time corrections require more complex throughput formulations, usually known as the hybrid models [3][12][13][14][15], in which more than one unknown parameters need to be estimated prior to the estimation of N_{in} .

- Some solutions may be so time/resource consuming that only their off-line application is actually feasible. For instance, a separate experiment for determining the dead-time, as well as iterative numerical procedures for calculating N_{in} could be required, as no closed-form inverse formula exists for Eq. 1. Another example is the time-interval method which needs calculating a histogram and a subsequent application of fitting procedures [6][10].
- All the above solutions assume a continuous radiation flux and therefore are not straightforwardly applicable to the case of pulsed radiation fluxes.

This paper presents two methods for count-loss correction which overcome these limitations. The proposed methods are based on the logical combination of the output signals from two separate detectors in the same radiation field after the discrimination stage of the readout electronics, and rely on the hypotheses that the signal duration is equal to the system dead-time and that the time distributions of the input particles in the two detectors are not correlated.

The proposed methods are easily applicable to systems based on segmented detectors and modern digital circuits for signal processing. In particular, the methods are intended for correction of pile-up effects in a system used to detect and count single pulses of a charged particle or photon beam, but they could be adapted to more general applications in radiation monitoring.

The output logical pulses from the two channels are assumed to be sampled in a digitizer or a Field Programmable Gate Array (FPGA) for further processing, and combined to provide the time evolution of their AND and OR logical synthesis. In one of the algorithms, called the “two-channel Time Combination” (TC) method, the count-loss correction is based on the comparison of the total time of the individual logical signals from the two channels with the time of their logical AND combination. In a second algorithm, called the “two-channel Count Combination” (CC) method, the number of counted pulses for the two channels is compared with the number of counted pulses of their OR combination.

In the following sections, both the proposed methods are assessed with simulations of ideal signals under different conditions of having a paralyzable or non-paralyzable system as well as a continuous or pulsed structure of the radiation flux, assuming in both cases a Poissonian distribution for the particle flux.

2. Methods

Fig. 1 indicates a schematic view of the proposed processing systems in which two independent detectors are crossed by N_1^{in} and N_2^{in} particles and their outputs are discriminated with respect to a fixed threshold V_{thr} and processed in a FPGA. In the following study it is assumed that the output from the discriminator is a logical signal whose duration is equal to the system dead-time. The output signals are discretized in a FPGA with a sampling period lower than the signal duration, providing for each input channel a flux of digits synchronous with a slower FPGA clock. The digital data-flows are used to detect transitions and increment counters with the number of pulses (N_1^{out} and N_2^{out}) and with the number of clocks with active signals (proportional to the time duration of signals in the two channels, T_1 and T_2). In parallel, the sampled waveforms are combined in logical AND and OR combinations, used to

increment counters with the number of clocks when the AND signal is active (proportional to the total time of the AND signal: T_{AND}) and the number of transitions detected in the OR data-flow (N_{OR}), respectively. The total number of clocks during the acquisition (proportional to the total acquisition time T_{acq}) is also saved to convert the number of counts to counting rates. The underlying concept of the proposed methods, based on the values stored in these counters, is presented in sections 2.1 and 2.2. In the description of the methods, it is assumed an infinite sampling and processing frequency, so that the number of counts N_1^{out} , N_2^{out} and N_{OR} are not affected by additional FPGA sampling effects, and the times T_1 , T_2 and T_{AND} are the effective durations of the logical signals after the discriminator and of their AND combination. The effect of the finite sampling frequency will be discussed in section 3.2.

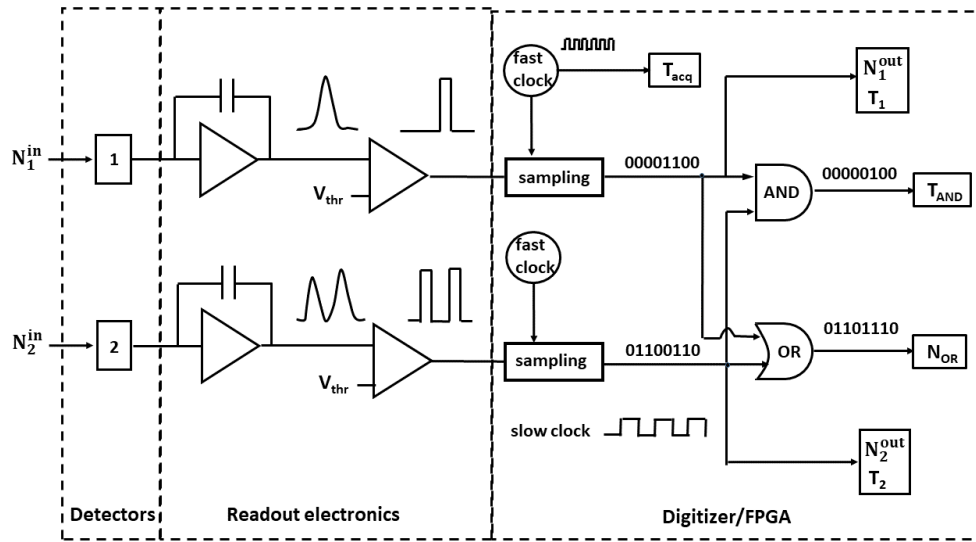

Fig. 1. Schematic view of the proposed processing systems.

It is assumed in addition that the radiation flux is continuous with random distribution of events over time. A pulsed time distribution of the radiation flux, corresponding for example to a bunched beam structure in particle counting applications, is also considered in the following, with a constant bunch period T_{bunch} and duty cycle DC, and a random distribution of particles inside each bunch.

2.1. Two-channel Time Combination method

The two-channel Time Combination (TC) method originates from the evidence that in a radiation detection experiment each particle which interacts with the active volume of the detector is either “counted” successfully or “lost” if the interaction occurs during the dead time interval generated by a previous event. If P_C and P_L are the probabilities of successful counting and losing counts, respectively, we have:

$$P_C + P_L = 1 \quad (3)$$

This statement must be true regardless of the paralyzable or non-paralyzable behavior of the system, or the continuous or pulsed radiation flux. The probabilities P_C and P_L can be written as follows:

$$P_C = \frac{N_{out}}{N_{in}} \quad (4)$$

$$P_L = \frac{T_{tot}}{T_{acq}} \quad (5)$$

where N_{in} is the number of input particles, N_{out} the number of detected pulses, T_{tot} the sum of the durations of the acquired signals and T_{acq} the total acquisition time. Combination of Eqs. 3, 4 and 5 results in:

$$N_{in} = \frac{N_{out}}{1 - \frac{T_{tot}}{T_{acq}}} \quad (6)$$

which is the standard live-time correction formula.

In a realistic readout system based on FPGA processing, the times T_{tot} and T_{acq} can be estimated from the number of clocks ($T_{1,2}$ and T_{acq} in Fig. 1), and N_{out} can be determined by counting the number of transitions in the logic processor (N_1 or N_2).

Eq. 6 is always valid under the assumption that the probability to lose counts (P_L) is uniform over time. When P_L is not constant, for example in bunched fluxes, the correction is valid only in short time intervals where the radiation flux can be assumed as Poissonian. A more general solution, valid also for bunched time-structures, requires using the information from more than one detector-

Two independent detectors (not necessarily with the same detection efficiency and geometrical acceptance) are assumed to be exposed simultaneously to the same radiation field. Each detector provides logical signals, whose number (N_1^{out} and N_2^{out}) and total durations (T_1, T_2) are measured in a given acquisition time T_{acq} . Under these assumptions, Eq.5 gives the probability of count loss during the acquisition period: T_1/T_{acq} and T_2/T_{acq} for detectors 1 and 2, respectively. If the logic AND of the two channels is considered, the probability that the two detectors are simultaneously unable to count is T_{AND}/T_{acq} , where T_{AND} is the summation of all times when the AND signal is active. The latter probability can also be obtained from the multiplication rule of probabilities:

$$\frac{T_{AND}}{T_{acq}} = \frac{T_1}{T_{acq}} \cdot \frac{T_2}{T_{acq}} \quad (7)$$

A rearrangement of Eq. 7 provides:

$$\frac{T_1}{T_{acq}} = \frac{T_{AND}}{T_2} \quad (8)$$

By substitution of Eq. 8 in Eq. 6:

$$N_1^{in} = \frac{N_1^{out}}{1 - \frac{T_{AND}}{T_2}} \quad (9)$$

A similar procedure for detector 2 gives:

$$N_2^{\text{in}} = \frac{N_2^{\text{out}}}{1 - \frac{T_{\text{AND}}}{T_1}} \quad (10)$$

Eqs. 9 and 10 are the correction formulae of the TC method.

2.2. Two-channel Count Combination method

While the TC correction method relies on time measurements, the two-channel Count Combination (CC) method is based on the count of the number of output pulses from the two detectors and of their OR logical combination. In general, the two detectors do not have necessarily the same acceptance, so that the average number of input counts for the second detector is assumed k times that of the first one:

$$N_2^{\text{in}} = kN_1^{\text{in}} \quad (11)$$

The probability to lose counts in each of the two channels is given by:

$$P_{L,1} = 1 - P_{c,1} = 1 - \frac{N_1^{\text{out}}}{N_1^{\text{in}}} \quad (12)$$

$$P_{L,2} = 1 - P_{c,2} = 1 - \frac{N_2^{\text{out}}}{kN_1^{\text{in}}} \quad (13)$$

where $P_{c,1}$ and $P_{c,2}$ are the probabilities to detect an event in detectors 1 and 2, respectively. The probabilities for count losses and successful count in the OR combination of the two channels are respectively

$$P_{L,\text{OR}} = P_{L,1} + P_{L,2} - P_{L,1}P_{L,2} \quad (14)$$

$$P_{c,\text{OR}} = \frac{N_{\text{OR}}}{N_1^{\text{in}} + N_2^{\text{in}}} = 1 - P_{L,\text{OR}} \quad (15)$$

From the previous equations (Eq. 12 to 15), the following correction formula can be derived:

$$N_1^{\text{in}} = \frac{(k+1)N_1^{\text{out}}N_2^{\text{out}}}{kN_{\text{OR}}} \quad (16)$$

while the input counts of detector 2 can be determined from Eq. 11.

2.3. Properties of the TC and CC methods

The corrections based on Eqs. 9, 10 and 16 do not depend on the specific dead-time model, they do not require the determination of the dead-time and are expected to work even for pulsed fluxes. Once the input rates $N_{1,2}^{\text{in}}$ are determined, the dead-time τ can be estimated by inverting Eq. 1 or Eq. 2 if the pile-up model of the system is known. For a continuous radiation flux, the estimated τ is the intrinsic dead-time of the system τ_{int} , while for a pulsed flux, for example when the detectors intercept a bunched

particle beam, it depends on the duty cycle of the beam and therefore, on the instantaneous rate. In this case, the estimated τ represents an effective dead-time τ_{eff} , related to τ_{int} and to the beam duty cycle (DC):

$$\tau_{\text{int}} = \tau_{\text{eff}} \text{DC} \quad (17)$$

The intrinsic dead-time τ_{int} can also be estimated by measuring the signal duration at low rate conditions, where the pile—up effects are negligible. In case of pulsed flux, the comparison of the effective dead-time τ_{eff} estimated by inverting Eq.1 or Eq.2 with a independent determination of the intrinsic dead time, provide information on the DC, i.e. the fine time structure of the particle flux.

In Eq. 16, the factor k (in the following named “relative acceptance”) is assumed to be known. In general, it can be determined by the comparison of counts of the two detection systems at low-rate conditions, where count loss effects are negligible.

It has to be remarked that the measurement of the number of counts of the OR logical combination is equivalent to the use of the number of counts of the AND combination, since $N_{\text{OR}} = N_1 + N_2 - N_{\text{AND}}$.

3. Results

This section describes a numerical study of the two methods. Both methods were assessed by simulating ideal Poisson-distributed pulses with the dead-time modelled with boxcar functions of fixed duration according to a paralyzable or non-paralyzable system. The effects of a finite sampling period and of different input fluxes to the two detectors were analyzed.

3.1. Simulation of ideal logical signals

The simulation used to assess the correction methods is based on the generation of waveforms containing the evolution of the system dead-time. The times of the input pulses are generated by following a Poisson distribution with a given input rate, and for each pulse a boxcar with a fixed length τ_{int} and unit amplitude, starting at the arrival time of the pulse, is added to the waveform. In the simulation of a non-paralyzable system, the boxcar is not added if the pulse occurs during the dead time of a previous pulse. These waveforms contain the time distribution of the logical signals produced by each channel of the detection systems after the amplification and discrimination stages, without accounting for detection inefficiencies or noise effects, and assuming ideal paralyzable or non-paralyzable system behaviors with fixed dead-time.

In the following study, two independent sets of waveforms are simulated for the two channels, each one specified by the dead-time fixed at $\tau_{\text{int}} = 1.5 \text{ ns}$, with a waveform duration of $T_{\text{acq}} = 250 \text{ }\mu\text{s}$, and a sampling frequency of the time information equal to 40 GHz, corresponding to a sampling period much shorter than the duration of each individual boxcar. The effect of a lower sampling frequency, closer to the possibilities of digital processing systems based on modern FPGA, will be investigated in a following section. These parameters are intended to simulate the output of a device based on segmented thin silicon detectors to detect and count individual pulses from charged particle or photon radiation fluxes.

However, the results are presented in terms of $f_{in}\tau$ products and do not change if the dead-time and counting frequencies are changed with inverse proportionality.

Figs. 2a and b illustrate an example of waveforms with the dead-time distribution of a paralyzable system for radiation fluxes with continuous and pulsed time-structures both at the mean pulse rate $f_{in,mean} = 50$ MHz. In the waveforms of Fig. 2 the boxcars are associated to each input pulse and summed up, to visualize the overlapping signals when the amplitude is larger than 1. For instance, an amplitude 3 indicates the superposition of the dead-times of three pulses for that sample. The number of output pulses is determined for each waveform as the number of transitions from 0.

In Fig. 2b, the pulses are packed in bunches, with random time distribution inside each bunch and the same mean pulse rate. In the example of Fig. 2b, the bunches are repeated every $T_{bunch} = 1 \mu s$ and the duration of each bunch is $0.3 \mu s$ corresponding to a duty cycle $DC = 0.3$. Inside each bunch the number of pulses is Poisson distributed with a mean value $T_{bunch}f_{in,mean} = (1 \mu s)(50 \text{ MHz}) = 50$. This number divided by the bunch duration gives the intra-bunch instantaneous pulse rate $50/(0.3 \mu s) = 167 \text{ MHz}$. In the viewpoint of count losses due to pile-up effects, such condition is equivalent to having a continuous beam with a pulse rate 50 MHz and an effective dead-time $\tau_{eff} = \tau_{int}/DC = 5 \text{ ns}$ (Eq. 17). Dead-time multiplied by pulse rate (τf) presents a measure of the severity of saturation [4][16].

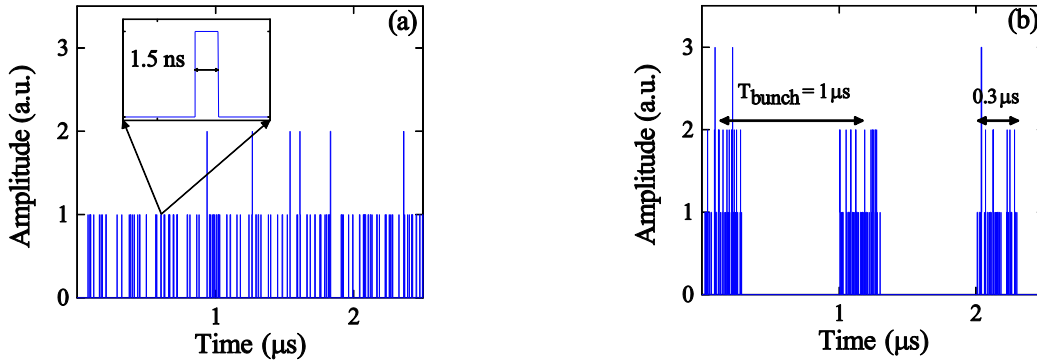

Fig. 2. Simulation of random distributed boxcars representing the dead-time evolution for a continuous (a) and for a bunched (b) irradiation at the average pulse rate of 50 MHz. The inset figure in (a) shows a single pulse with a duration 1.5 ns and amplitude 1.

To investigate the performance of the proposed methods under various conditions, four different cases were considered: continuous and pulsed fluxes, each with both paralyzable and non-paralyzable systems. Different input mean rates were considered to evaluate the effectiveness of the correction methods as a function of the count-loss severity. The analysis employs a number of independent waveforms, such to keep the statistical errors on the number of counts below 1%.

For each case of study, the number of pulses detected from two independent sets of waveforms (N_1^{out} and N_2^{out}), the number of pulses of their OR combination (N_{OR}), and the corresponding signal durations (T_1 , T_2 and T_{AND}) were used to estimate the number of input pulses corrected for pile-up effects and the corresponding pulse rate (f_{corr}) using Eqs. 9, 10 and 16. In the following, the input frequencies of the two independent channels are the same, and the factor k of Eq. 16 is therefore fixed at 1.

Results are shown in Fig. 3, where the normalized corrected rates are shown as a function of the normalized input mean rates (both multiplied by τ_{int}) for the different case studies and for the two different correction methods. The corrections by the live-time method, as well as the uncorrected counting rate (f_{out}) are also shown.

In order to assess the uncertainty of the results, all calculations were repeated 20 times, the results were averaged and their standard deviation computed and reported as error bars in Fig. 3. Counting efficiencies (defined as the ratio of the corrected and input mean frequencies, $\eta = f_{\text{corr}}/f_{\text{in,mean}}$) were also calculated and illustrated, where $\eta = 1$ corresponding to the ideal case of perfect correction.

According to Fig. 3, failure of the live-time correction method for bunched fluxes is evident. The TC method recovers the input rates under different working situations, as expected from the theoretical discussion in section 2.1. The outputs of the CC method are comparable; however, for a pulsed flux with paralyzable system (Fig. 3e and f), it fails to work at very high rates ($\tau_{\text{int}}f_{\text{in}} > 0.5$).

Based on the results shown in Fig. 3, the dead-times were calculated both for paralyzable and non-paralyzable systems respectively by inverting Eqs. 1 and 2. Results are illustrated in Fig. 4, where for continuous beams an intrinsic dead-time of $\tau_{\text{int}} = 1.5$ ns is ideally expected (see Figs. 4a and b). On the other hand, for bunched fluxes, an effective dead-time $\tau_{\text{eff}} = 5$ ns is expected according to Eq. 17 (see Figs. 4c and d). The agreement of the results with the expectations suggests the possibility to use the reconstructed dead-times for investigating the time-structure of pulsed radiation fluxes, as discussed in Sect. 2.3.

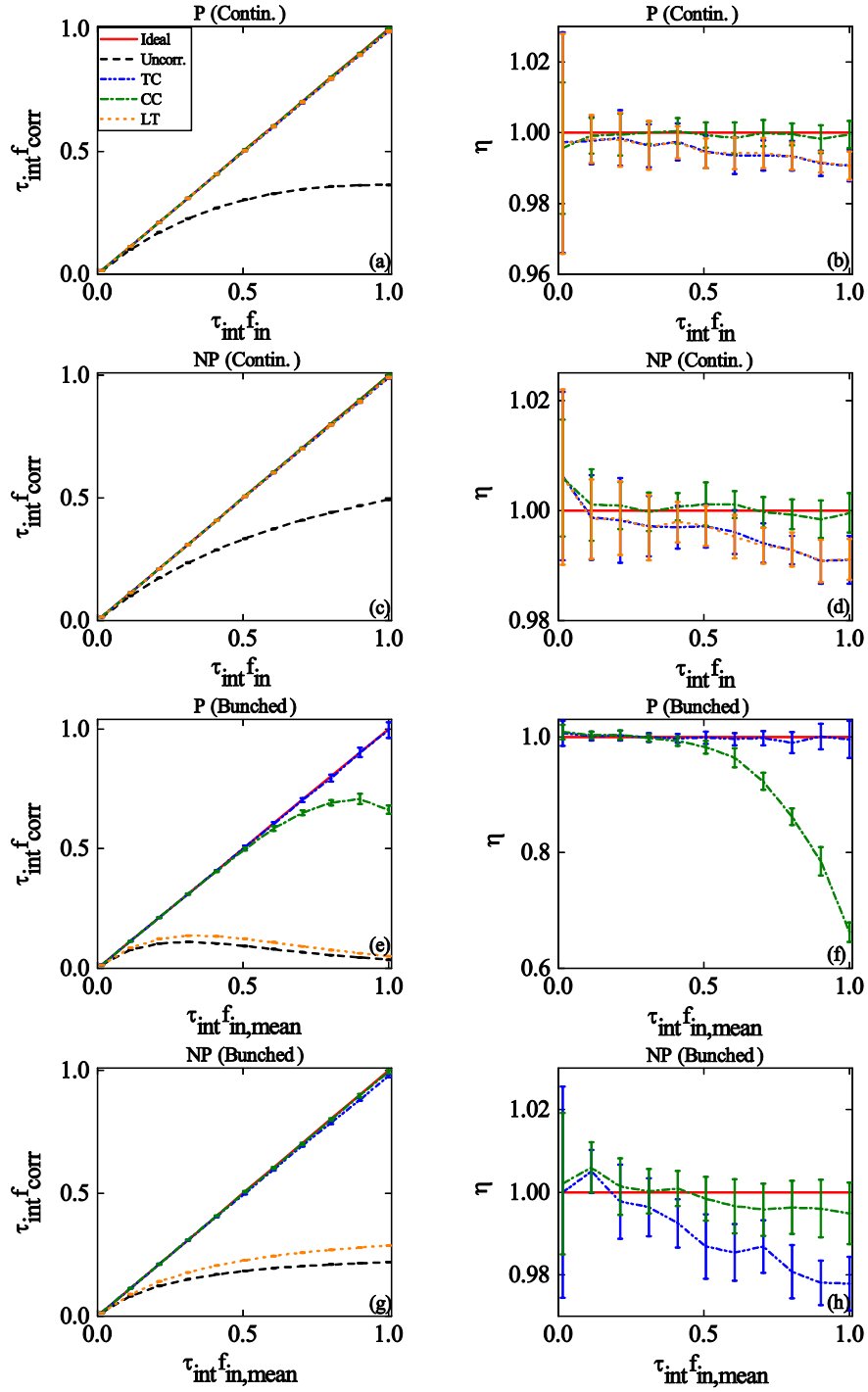

Fig. 3. Performance of the two methods (TC and CC) for continuous beam with paralyzable (a,b) and non-paralyzable (c,d) system, as well as for bunched flux with paralyzable (e,f) and non-paralyzable (g,h) system. For one of the two channels, results of the live-time (LT) correction method, as well as the uncorrected rate are also illustrated for comparison. Vertical and horizontal axes indicate respectively the corrected and input rates normalized by $\tau_{int} = 1.5$ ns.

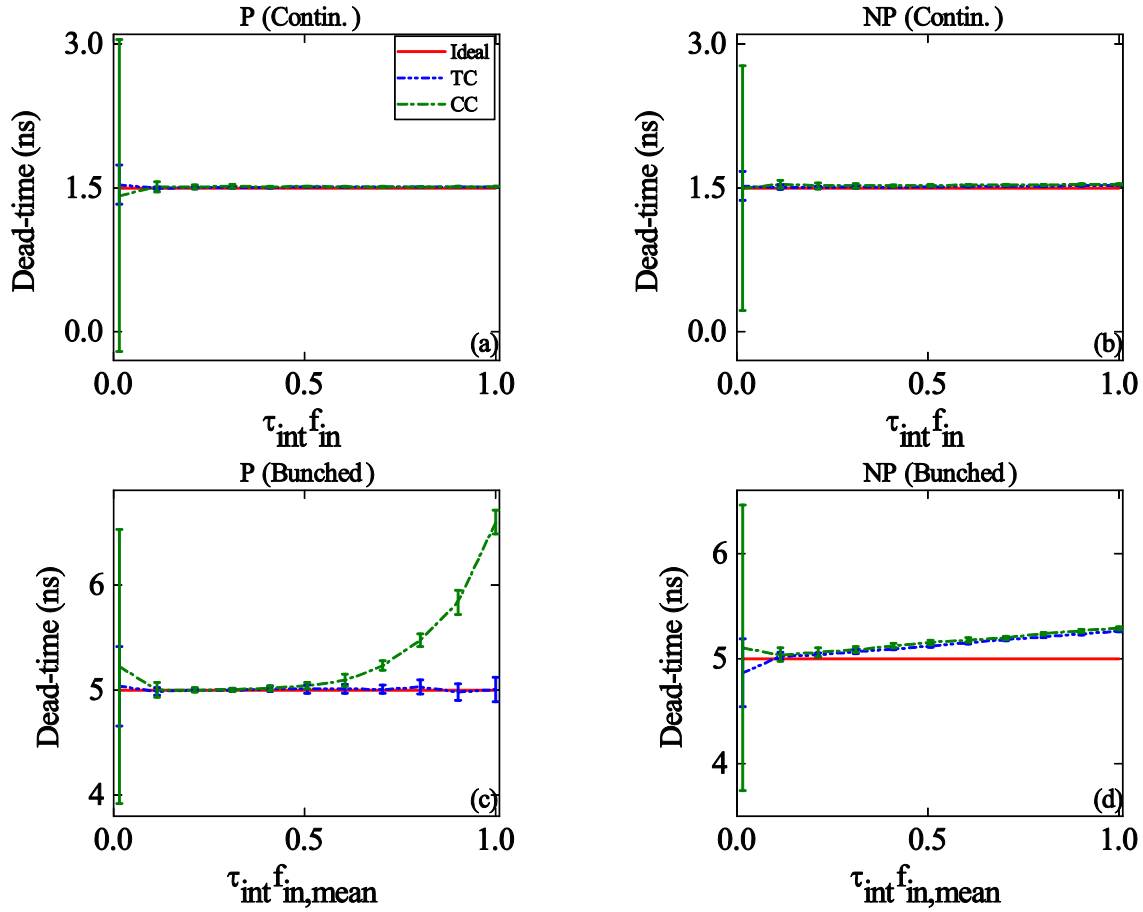

Fig. 4. Reconstructed dead-times obtained from Eqs. 1 and 2 using the corrected counts shown in Fig. 3. Results for the cases of continuous beam with paralyzable (a) and non-paralyzable (b) system, as well as for bunched beam with paralyzable (c) and non-paralyzable (d) system are illustrated.

It is worth noting that count-loss inefficiencies and correction results depend only on the instantaneous rate, and therefore the same results are expected for a continuous beam at the rate f_{in} and for a pulsed flux at an instantaneous rate f_{in}/DC , as discussed before. The correction results can be better evaluated from Fig. 5, where the counting efficiencies, defined as the ratios of the number of counts after the correction over the number of input pulses, are shown as a function of the normalized input rate. In this figure, the normalization factor for the input frequencies is τ_{int} in the case of continuous beam, while for a bunched beam the value $\tau_{eff} = \tau_{int}/DC$ was used. In the frequency range shown in these plots, both the correction methods applied to ideal pulses recover the count-losses due to pile-up effects within the statistical errors, with the exception of the simulation of a non-paralyzable system and bunched time distribution (solid curves in Figs. 5c and d), where an offset of about 1% in the corrected rates appears.

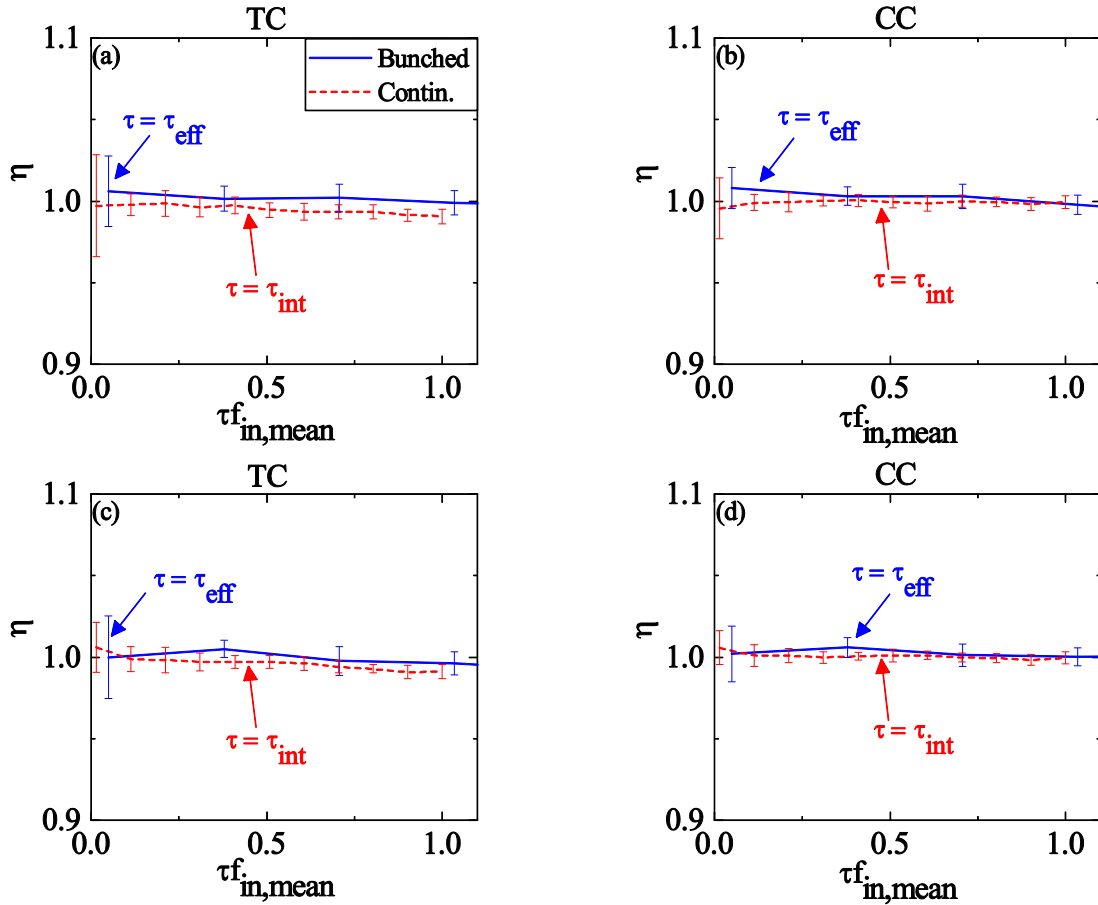

Fig. 5. Ratio of corrected and input rates (η) as a function of the normalized input pulse rate for paralyzable (a and b) and non-paralyzable (c and d) systems. For the case of continuous beams, the input rate in the x-axis is scaled by τ_{int} , while for bunched beams it is scaled by τ_{eff} .

3.2. The effect of sampling frequency

All the waveforms used in the previous study were generated with a high sampling frequency of 40 GHz. The effect of lower sampling frequencies is investigated in this section to understand how the correction methods perform in a realistic logical system implemented in a FPGA or offline with signals with limited sampling frequency. As a case study, a continuous beam with paralyzable system was simulated by sampling the dead-time waveforms at a set of sampling frequencies (40, 10, 5, 2 and 1 GHz). The uncorrected output rates and the effect of the correction procedures are shown in Fig. 6 for each sampling frequency.

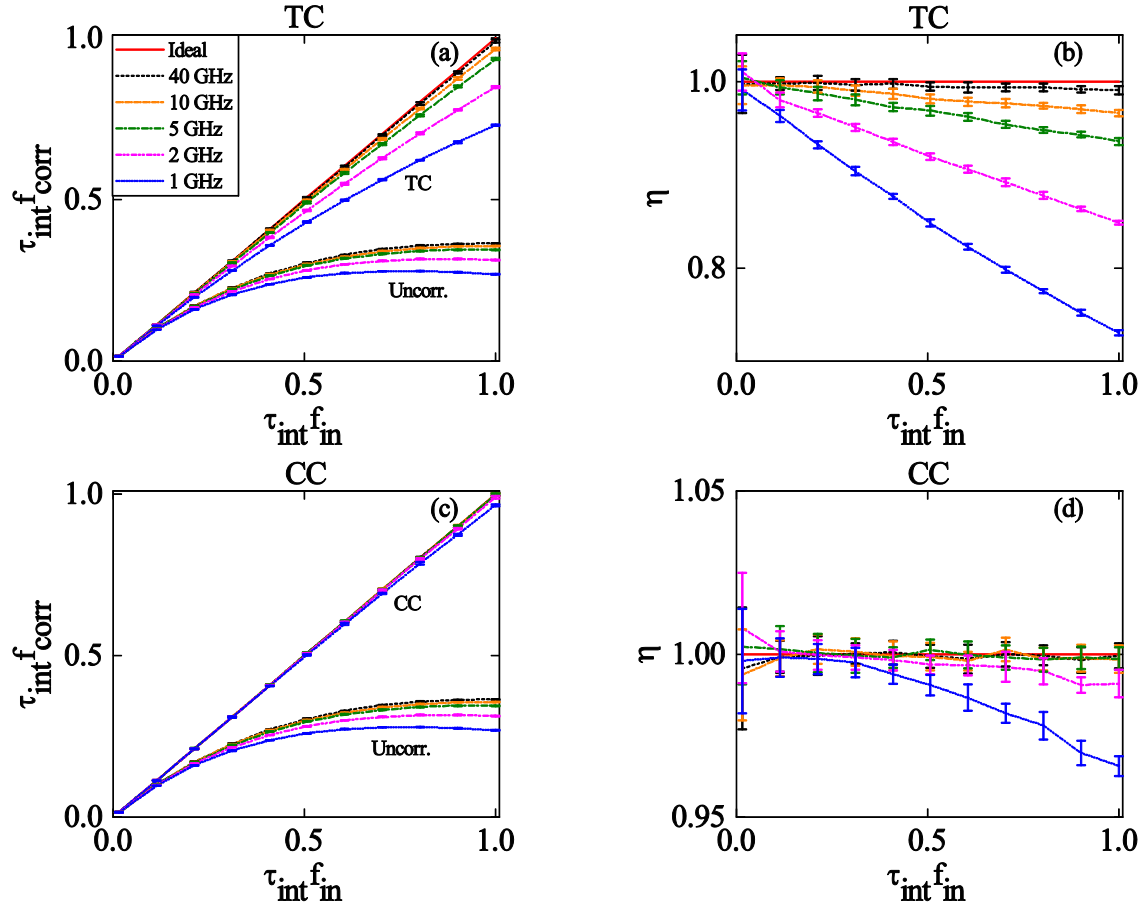

Fig. 6. Normalized corrected rates as a function of the input rate under different sampling frequencies, for the TC (a) and CC (c) correction methods for a continuous beam with paralyzable system. The uncorrected output rates at different sampling frequencies are also shown for comparison. The corresponding η -ratio plots are shown in (b) and (d), respectively.

According to the results shown in Fig. 6, by lowering the sampling frequency, the results of the TC method start to degrade while the CC method is more solid. The reason is that the TC method is based on the estimation of the pulse durations from the count of number of samples. This time estimation is not accurate at low sampling frequencies where the number of samples available for each individual pulse is low. The CC method, on the other hand, is based on the number of counts, and is less affected by a reduction of the sampling frequency, if the sampling period is below the pulse duration.

3.3. The effect of unequal pulse rates

The methods are expected to work even when the pulse rates from the two channels are not equal, for instance in case the two detectors have different geometrical efficiencies, if the relative acceptance is known or determined with measurements at low rates where count loss effects are negligible. As a numerical evaluation, a simulation was performed with relative acceptance $k = N_2^{in} / N_1^{in} = 2$, using a sampling frequency of 40 GHz and a paralyzable dead-time behavior. Fig. 7 reports the corrected versus input pulse rates for continuous and pulsed fluxes and a paralyzable system, with the results for both the detectors 1 and 2 included according to the k scale of the corresponding input frequencies.

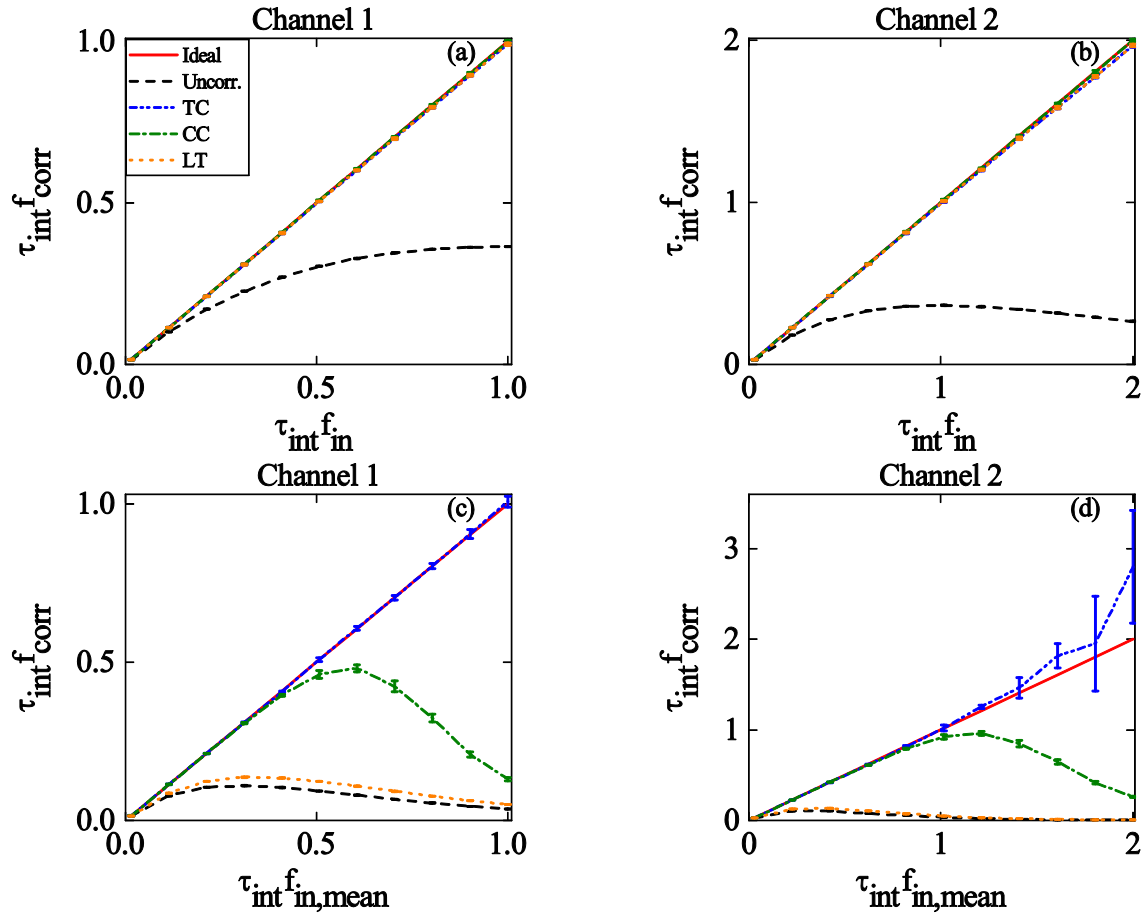

Fig. 7. Normalized count rates before and after corrections for continuous beam (top) and bunched beam (bottom) as a function of the normalized input rates for channel 1 (left) and channel 2 (right) at the two channels for a paralyzable system and a relative acceptance $k=2$.

Figs. 7a and b reveal the functionality of both methods in recovering the unequal input rates of the two detectors simultaneously exposed to continuous beams, while the performance of the CC method starts to degrade for bunched beam and $\tau f > 0.5$. In Fig. 7d, the severity of saturation becomes so high that also the TC method starts to fail by overestimating the results. At such high rates, both the numerator and denominator terms of Eq. 10 approach zero, and the output of the correction formula becomes mathematically undefined.

4. Conclusions

Two algorithms for correction of inefficiency effects in radiation pulse counting are introduced and validated by simulating ideal signals with fixed duration equal to the dead-time, assuming both paralyzable and non-paralyzable systems and continuous or pulsed radiation fluxes. Both algorithms are based on the correlation of measurements from two independent detectors under the same radiation flux, employing logical combinations of signals implemented in the readout electronics or in a FPGA. The first algorithm, here called the “two-channel Time Combination” (TC) method, is based on the measurement of the time duration of single signals from the two detectors and of their AND

correlation. The second algorithm, called the “two-channel Count Combination” (CC) method is based on counting the number of transitions of the OR combination of the two signals.

The numerical studies presented in section 3.1 showed that both methods provide very good results on the base of simulation of ideal signals, except for pulsed radiation fluxes in paralyzable model where the TC is more robust than the CC method at very high instantaneous rates. However, the TC method relies on precise measurements of the signal durations, and a degradation of its performance is expected if the precision of the time measurement is not high enough.

The corrections do not rely on any parameters known in advance if the system ideally behaves with logical output signals for each input pulse produced with durations equal to the dead-time of the system. This assumption is valid for solid-state detectors (e.g. silicon sensors and HPGe detectors), where the intrinsic dead-time, often limited by the amplification or conversion electronics, follows with good approximation the duration of the output signals. In particular, these methods can be applied to correct in real-time for counting inefficiencies in segmented solid-state detectors used to monitor charged particle or photon beam fluxes, giving at the same time information on the radiation time-structure for bunched beams.

However, the technique is more general and could be used in different radiation instrument applications (scintillation detectors, Geiger-Muller tubes, etc.). In all cases, the effectiveness of the correction algorithm must be evaluated and optimized keeping in mind that the corrections can also be affected by different effects depending on the choice of detector, electronic design, radiation type, noise level and threshold value.

Acknowledgements

M. R. Mohammadian-Behbahani appreciates the financial support by the Iranian Ministry of Science, Research and Technology (MSRT) for taking a research period at the University of Torino, Italy, during which this collaboration began.

References

- [1] R.D. Evans, R.D. Evans, *The atomic nucleus*, McGraw-Hill New York, 1955.
- [2] W. Feller, On probability problems in the theory of counters, in: *Sel. Pap. I*, Springer, 2015: pp. 751–759.
- [3] S. Usman, A. Patil, Radiation detector deadtime and pile up: A review of the status of science, *Nucl. Eng. Technol.* (2018).
- [4] G.F. Knoll, *Radiation detection and measurement*, John Wiley & Sons, 2010.
- [5] S. Pomme, R. Fitzgerald, J. Keightley, Uncertainty of nuclear counting, *Metrologia*. 52 (2015) S3.
- [6] L. Abbene, G. Gerardi, High-rate dead-time corrections in a general purpose digital pulse

processing system, *J. Synchrotron Radiat.* 22 (2015) 1190–1201.

- [7] C. Michotte, M. Nonis, Experimental comparison of different dead-time correction techniques in single-channel counting experiments, *Nucl. Instruments Methods Phys. Res. Sect. A Accel. Spectrometers, Detect. Assoc. Equip.* 608 (2009) 163–168.
- [8] R. Fitzgerald, Corrections for the combined effects of decay and dead time in live-timed counting of short-lived radionuclides, *Appl. Radiat. Isot.* 109 (2016) 335–340.
- [9] D.F. Covell, M.M. Sandomire, M.S. Eichen, Automatic compensation of dead time in pulse analysis equipment, *Anal. Chem.* 32 (1960) 1086–1090.
- [10] E. Gilad, C. Dubi, B. Geslot, P. Blaise, A. Kolin, Dead time corrections using the backward extrapolation method, *Nucl. Instruments Methods Phys. Res. Sect. A Accel. Spectrometers, Detect. Assoc. Equip.* 854 (2017) 53–60.
- [11] M. Boromiza, C. Borcea, A. Negret, A. Olacel, G. Suliman, Dead time corrections for inbeam γ -spectroscopy measurements, *Nucl. Instruments Methods Phys. Res. Sect. A Accel. Spectrometers, Detect. Assoc. Equip.* 863 (2017) 15–19.
- [12] S.H. Lee, R.P. Gardner, A new G–M counter dead time model, *Appl. Radiat. Isot.* 53 (2000) 731–737.
- [13] A. Patil, S. Usman, Measurement and application of paralysis factor for improved detector dead-time characterization, *Nucl. Technol.* 165 (2009) 249–256.
- [14] L. Takacs, On a probability problem in the theory of counters, *Ann. Math. Stat.* 29 (1958) 1257–1263.
- [15] J.W. Müller, Generalized dead times, *Nucl. Instruments Methods Phys. Res. Sect. A Accel. Spectrometers, Detect. Assoc. Equip.* 301 (1991) 543–551.
- [16] M.-R. Mohammadian-Behbahani, S. Saramad, Pile-up correction algorithm based on successive integration for high count rate medical imaging and radiation spectroscopy, *Nucl. Instruments Methods Phys. Res. Sect. A Accel. Spectrometers, Detect. Assoc. Equip.* 897 (2018) 1–7.
- [17] H.-W. Sadrozinski, S. Ely, V. Fadeyev, Z. Galloway, J. Ngo, C. Parker, B. Petersen, A. Seiden, A. Zatserklyaniy, N. Cartiglia, Ultra-fast silicon detectors, *Nucl. Instruments Methods Phys. Res. Sect. A Accel. Spectrometers, Detect. Assoc. Equip.* 730 (2013) 226–231.